

SSU-2000 Synchronization Supply Unit and the SDU-2000 Synchronization Distribution Unit

User Guide
Revision F – October 2006
Part Number 12713020-002-2

Symmetricom, Inc.
2300 Orchard Parkway
San Jose, CA 95131-1017
U.S.A.

<http://www.symmetricom.com>

Copyright © 1999–2005 Symmetricom, Inc.
All rights reserved. Printed in U.S.A.

All product names, service marks, trademarks, and registered trademarks
used in this document are the property of their respective owners.

Contents

How to Use This Guide

Purpose of This Guide	18
Who Should Read This Guide.	18
Structure of This Guide	19
Conventions Used in This Guide.	19
Warnings, Cautions, Recommendations, and Notes	20
Related Documents and Information.	21
Where to Find Answers to Product and Document Questions	22
What's New in This Document	22

Chapter 1 Product Overview

Overview	24
Typical System Configurations.	25
Timing Signal Generator (TSG) Configuration	25
Primary Reference Source (PRS) Configuration.	26
SSU-2000 Configured as a Monitor-Only System.	26
System Architecture	27
Input Section	28
Output Section.	31
Clock Section	31
Communications Section.	31
Alarms and Events	32
System Components	34
SSU-2000 Main Shelf (Chassis)	34
SSU-2000 Family of Modules	40
Clock and Communications Modules	41
Input Modules	42
Output Modules	44
Configuring Redundant Output Modules.	46
Input and Output Adapter Panels.	47
Communications Protocol	49
Software Interface	49
Software Versions	50
Basic System Load	50
Graphical User Interface	51
Overview of SSU-2000 Operation	51
Synchronization Status Messages (SSMs).	51
Indicators and Controls	53
SDU-2000 Synchronization Distribution Unit	53
Functional Overview	54
Expansion Shelf Features	55
Setting the Expansion Shelf Address	57

Buffered Clocks	57
SDU Module Features	57
Connector Panel Features	58
Controls and Indicators	58

Chapter 2 Installing the SSU-2000

Unpacking and Inspecting the Shelf	60
Preliminary Procedures	60
Installation Tools and Materials	61
Electromagnetic Interference (EMI) Considerations	61
Ventilation Considerations	62
Rack Mounting the SSU-2000	62
SSU-2000 Shelf	62
I/O Adapter Panels	64
Making Ground and Power Connections	64
Making Ground Connections	65
Connecting Power	66
Making Signal Connections	66
Making I/O Connections	66
Installing Output Summer Adapters	68
Making Communication Connections	70
Making Ethernet Connections	72
Local Oscillator Outputs	72
Remote Reset	72
Making Alarm Connections	73
Connecting Antennas	75
Connecting an SDU-2000 Expansion Shelf	75
Connecting a Single SDU-2000 Expansion Shelf	77
Connecting Additional SDU-2000 Expansion Shelves	78
Handling Modules	81
Installing a Module	81
Exchanging a Module	82
Disabling a Module	83
Removing Modules	84
Installation Checklist	85
Powering Up the SSU-2000	86
SSU-2000 Main Shelf	87
SDU-2000 Expansion Shelf	87
Normal System Indications During Turn-Up	87
After Turn Up	88

Chapter 3 Provisioning and Operating the SSU-2000

Controls and Indicators	90
SSU-2000 Status LED Indicators	90
SSU-2000 Operating Controls.	90
Establishing a Connection With the SSU-2000	90
Communicating by Serial Port.	91
Communicating by Ethernet	92
Overview of the SSU-2000 Security System	93
Adding An Administrator-Level User to the System.	95
Adding Users to the System.	96
Setting Security Parameters	98
Logging In to the SSU-2000	102
Logging In with an Expired Password.	103
Logging Off of the SSU-2000	105
Initial Provisioning	105
Provisioning General Parameters	105
Adding or Enabling a Module	106
Disabling a Module	107
Removing a Module	107
Provisioning GPS Input Modules.	108
Provisioning Other Input Modules	109
Provisioning Output Modules	111
Saving the Provisioning Setup	112
Checking Alarm Status.	113
Factory Default (Basic) Configuration	113
Changing Factory Defaults	113
Restoring Factory Defaults	114
Customizing Other Configuration Options.	114
Backing Up and Restoring Configurations	115
Backing Up the Configuration	115
Using ICS Commands.	115
Using TL1 Commands.	115
Restoring the Configuration	116
Using ICS Commands.	116
Using TL1 Commands.	116

Chapter 4 Commissioning

Readiness to Test Checklist.	118
SSU-2000 Commands	119
Equipment Requirements.	119
Commissioning Tests.	120
Testing the Ethernet Communications Interface.	120
Testing the EIA-232 Ports	120

Testing The MINOR Alarms	121
Testing the MAJOR Alarms.	121
Testing the CRITICAL Alarms.	122
Testing the Reference Signals and Selection	122
Testing the Clock Section	123
Testing the Output Section	123
Testing the System Stability and Accuracy (Optional)	124
Commissioning Test Data Sheet	124

Chapter 5 Maintenance and Troubleshooting

Responding to SSU-2000 Alarms	126
Preventive Maintenance.	126
Corrective Maintenance	127
Troubleshooting	129
Establishing a Connection.	130
Troubleshooting Guide	130
Interpreting Status Messages	131
Troubleshooting the SDU-2000.	134
Re-ordering Information	135
Equipment Return Procedure	135
Repacking the Unit	135
Equipment Return Procedure	136
Contacting Technical Support	136

Chapter 6 Clock Module Reference Data

Stratum 2E Clock Module	138
Functional Overview	138
Functional Block Diagram	139
Status LED Indicators	140
Functional Specifications.	141
Stratum 3E Clock Module	142
Functional Overview	142
Functional Block Diagram	143
Status LED Indicators	144
Performance Specifications.	145
Type 1 Clock Module	146
Functional Overview	146
Functional Block Diagram	147
Status LED Indicators	148
Functional Specifications.	149
Communications Module	150
Functional Overview	150
Functional Block Diagram	151
Status LED Indicators	152

Communications Module Alarm Logic	153
EIA-232 Ports	154
Ethernet Port	155
Resetting the Module	155

Chapter 7 Input Module Reference Data

1-Port and 3-Port E1 Input Modules	158
Functional Overview	158
Functional Block Diagram	159
Status LED Indicators	164
Software Options	166
1-Port and 3-Port DS1 Input Modules	167
Functional Overview	167
Functional Block Diagram	168
Status LED Indicators	173
Configuration Options	175
GPS Input Module	176
Functional Overview	176
Functional Block Diagram	176
Status LED Indicators	178
Configuration Options	179
Composite Clock Input Module	179
Functional Overview	179
Functional Block Diagram	180
Status LED Indicators	181
Configuration Options	182
Japanese Sine Wave Input Module	182
Functional Overview	182
Functional Block Diagram	183
Status LED Indicators	186
Configuration Options	187
Japanese Composite Clock Input Module	189
Functional Overview	189
Functional Block Diagram	190
Status LED Indicators	191
Configuration Options	192
Input Adapter Panels	192
Input Adapter Panel for 1-Port Input Module	192
Input Adapter Panel for 3-Port Input Modules	193
Input Wire-Wrap Adapters	195

Chapter 8 Output Module Reference Data

E1 Output Module	198
Functional Overview	198
Functional Block Diagram	199

Status LED Indicators	200
Performance Specifications.	201
DS1 Output Module	202
Functional Overview	202
Status LED Indicators	203
Performance Specifications.	204
Composite Clock Output Module	205
Functional Overview	205
Functional Block Diagram	206
Status LED Indicators	207
Performance Specifications.	208
Japanese Composite Clock Output Module.	209
Functional Overview	209
Functional Block Diagram	210
Status LED Indicators	211
Configuration Options	212
Japanese Sine Wave Output Module.	213
Functional Overview	213
Functional Block Diagram	213
Status LED Indicators	218
Configuration Options	219
E1/2048 kHz Output Module	219
Functional Overview	220
Functional Block Diagram	224
Status LED Indicators	225
E1/2048 kHz Output Signal Specifications	226
2048 kHz Output Module	227
Functional Overview	227
Functional Block Diagram	227
Status LED Indicators	231
Performance Specifications.	232
RS-422 Output Module	233
Functional Overview	233
Functional Block Diagram	233
Status LED Indicators	237
Performance Specifications.	238
DS1 Line Retiming Unit (LRU)	240
Functional Overview	242
Status LED Indicators	244
Installing the Line Re-timing Unit.	245
Specifications	252
Provisioning the DS1 Line Re-timing Module	252
Alarms and Events	253
E1 Line Re-timing Unit	253
Functional Overview	253
Status LED Indicators	255
Installing the E1 Line Re-timing Module	256

Installing the Output Panels	257
Specifications	258
Provisioning the E1 Line Re-timing Module	258
Alarms and Events	259
Buffer Module	259
Status Indicators	259
Output Adapter Panels	261
Balun Output Adapter Panel	261
DE9 Output Adapter Panel	261
High-Density Wire-Wrap Output Panels	262
Adapter Accessories	262

Chapter 9 Hardware Configuration Guide

Configuring a Conventional SSU/TSG System	266
Configuring a Primary Reference Source (PRS) System	266
Configuring a Monitor-Only System	267
Configuring a Subtending SSU	268
Functional Description	269
Input Section	269
Output Section	270
Setting Subtending Parameters	271
Changing to Subtending SSU Mode	272
Required Hardware	272
Installing Software	273
Changing From Subtending SSU Mode	273
SSU-2000 Configuration Chart	274

Index

Figures

1-1	SSU-2000 Synchronization Supply Unit.	24
1-2	SSU-2000 Configured as a TSG	25
1-3	SSU-2000 Configured as a Primary Reference Source.	26
1-4	SSU-2000 Configured as a Monitor-Only System	26
1-5	Block Diagram of the SSU-2000	27
1-6	Components in a Typical SSU-2000 Installation	35
1-7	Slot Numbering Assignments.	36
1-8	Rear Panel of the SSU-2000 Main Shelf	37
1-9	Location of Power Fuses on the Rear Panel	39
1-10	SSU-2000 Input/Output Connectors	46
1-11	I/O Adapter Panels for Input and Output Modules	48
1-12	Front View of the SDU-2000 Expansion Shelf	53
1-13	Rear View of the SDU-2000 Expansion Shelf	54
1-14	SDU-2000 Block Diagram	56
2-1	Shelf and I/O Adapter Rack Mounting	63
2-2	Frame and Logic Ground Jumpers	65
2-3	Power Terminal Blocks.	66
2-4	SSU-2000 Rear Panel	67
2-5	Installing the Output Summer Adapter.	68
2-6	DTE/DCE Slide Switch.	71
2-7	Alarm Terminal Blocks	73
2-8	SDU Interface (J8) and Backup Clock (J9) Connectors.	76
2-9	SDU Interface (J17 and J15) and Backup Clock (J16) Connectors.	76
2-10	SSU Interface (J8) Expansion Terminator	76
2-11	Wiring Diagram for a Single SDU-2000 Shelf	78
2-12	Wiring Diagram for Multiple SDU-2000 Shelves	80
2-13	SSU-2000 Power Fuses.	86
3-1	Direct Connection Using the Serial Port.	91
5-1	Alarm and Event Status Breakdown.	131
6-1	Block Diagram of the Stratum 2E Clock Module	139
6-2	Front Panel of the Stratum 2E Clock Module.	140
6-3	Block Diagram of the Stratum 3E Clock Module	143
6-4	Front Panel of the Stratum 3E Clock Module.	144
6-5	Block Diagram of the Type 1 Clock Module	147
6-6	Front Panel of the Type 1 Clock Module	148
6-7	Block Diagram of the Communications Module	151
6-8	Front Panel of the Communications Module	152
7-1	Block Diagram of the 1-Port and 3-Port E1 Input Modules	159
7-2	Front Panel of the E1 Input Module	165
7-3	Block Diagram of the 1-Port and 3-Port DS1 Input Module	168

7-4	Front Panel of the DS1 Input Module	174
7-5	Block Diagram of the GPS Input Module	177
7-6	Front Panel of the GPS Input Module	178
7-7	Block Diagram of the Composite Clock Input Module	180
7-8	Front Panel of the Composite Clock Input Module	181
7-9	Block Diagram of the Japanese Sine Wave Input Module	183
7-10	Front Panel of the Japanese Sine Wave Input Module	186
7-11	Block Diagram of the Japanese Composite Clock Input Module	190
7-12	Front Panel of the Japanese Composite Clock Input Module	191
7-13	Input I/O Adapter for One-Port Input Modules	193
7-14	I/O Adapter for 3-Port Input Modules	194
7-15	Input Wire-Wrap Adapter	195
8-1	Block Diagram of the E1 Output Module	199
8-2	Front Panel of the E1 Output Module	200
8-3	Block Diagram of the DS1 Output Module	202
8-4	Front Panel of the DS1 Output Module	203
8-5	Block Diagram of the Composite Clock Output Module	206
8-6	Front Panel of the Composite Clock Output Module	207
8-7	Block Diagram of the Japanese Composite Clock Output Module	210
8-8	Front Panel of the Japanese Composite Clock Output Module	211
8-9	Block Diagram of the Japanese Sine Wave Output Module	213
8-10	Using the Hex Number to Identify Output Ports	215
8-11	Front Panel of the Japanese Sine Wave Output Module	218
8-12	Using the Hex Number to Identify Output Ports	221
8-13	Block Diagram of the E1/2048 kHz Output Module	224
8-14	Front Panel of the E1/2048 kHz Output Module	225
8-15	Block Diagram of the 2048 kHz Output Module	228
8-16	Using the Hex Number to Identify Output Ports	229
8-17	Front Panel of the 2048 kHz Output Module	231
8-18	Block Diagram of the RS-422 Output Module	234
8-19	Using the Hex Number to Identify Output Ports	235
8-20	Front Panel of the RS-422 Output Module	238
8-21	Recommended Installation Schematic for the DS1 LRU	242
8-22	Block Diagram of the DS1 LRU Module	243
8-23	Front Panel of the DS1 LRU Four-Port Module	244
8-24	Recommended SSU-2000 Slots for Installing the DS1 LRM	246
8-25	SDU-2000 Recommended Slots for DS1 LRM Installation	247
8-26	Installing the Cut-Through Assembly in the SSU-2000	248
8-27	Installing the Cut-Through Assembly in the SDU-2000	249
8-28	Orientation of the SSU-2000 I/O and CTA I/O Connector Pins	251
8-29	Wire-wrap Identification Overlay	252
8-30	E1 LRM Block Diagram	254
8-31	Front Panel of the E1 LRM	255
8-32	Sample Rack Mounting with Input Module, SSU-2000, and Output Panel	257
8-33	DE9 Output Panel for the E1 LRU	258
8-34	BNC Output Panel for the E1 LRU	258
8-35	Front Panel of the Buffer Module	260

8-36	Balun Output I/O Adapter Panel for Output Module	261
8-37	Output I/O Adapter Panel, DE9 Outputs	261
9-1	Time Sync Generator (TSG) System Configuration	266
9-2	SSU-2000 Configured as PRS System	267
9-3	SSU-2000 Configured as Monitor-Only System	268
9-4	SSU-2000 I/O Adapter Panels	274
9-5	SDU-2000 Synchronization Distribution Unit	275

Tables

1-1	Slot Assignments for Specific Modules	36
1-2	Versions of Software for the Communications Module.	50
1-3	ANSI SSM Quality Level Definitions	52
1-4	ITU SSM Quality Level Definitions	52
1-5	Expansion Shelf Addresses	57
2-1	I/O Module Slot to I/O Connector Relationship	67
2-2	Communications Port Assignments	70
2-3	EIA-232 Connector Pin Assignments.	72
2-4	Alarm Relay Connections.	74
2-5	Communications and Buffer Module LED Indications	86
3-1	Communications Port Assignments	90
3-2	Firmware Requirements for Security Features	94
3-3	User Access Levels	95
4-1	SSU-2000 Readiness Checklist	118
4-2	Commissioning Test Data Sheet	124
5-1	SSU Corrective Action Table	128
5-2	SDU Corrective Action Table	129
5-3	SSU-2000 Troubleshooting Procedures	132
5-4	SDU-2000e Troubleshooting Procedures	134
6-1	Stratum 2E Clock Module Status LED Indicators.	140
6-2	Stratum 2E Clock Module Specifications	141
6-3	Stratum 3E Clock Module Status LED Indicators.	144
6-4	Stratum 3E Clock Module Performance Specifications	145
6-5	Type 1 Clock Module Status LED Indicators	148
6-6	Type 1 Clock Module Specifications	149
6-7	Communications Module Status LED Indicators	152
6-8	Communications Module Alarms	154
7-1	E1 Input Module Alarm Modes.	161
7-2	E1 Input Module Event Reporting	164
7-3	E1 Input Module Status LED Indicators	165
7-4	E1 Input Module Configuration.	166
7-5	DS1 Input Module Alarm Modes	170
7-6	DS1 Input Module Event Reporting	173
7-7	DS1 Input Module Status LED Indicators.	174
7-8	DS1 Input Module Configuration	175
7-9	GPS Input Module Status LED Indicators	178
7-10	GPS Input Module Configuration Settings	179
7-11	Composite Clock Input Module Status LED Indicators	181
7-12	Composite Clock Input Module Configuration Settings	182
7-13	Japanese Sine Wave Input Module Status LED Indicators	187
7-14	Japanese Sine Wave Input Module Configuration Settings.	187

7-15	Japanese Composite Clock Input Module Status LED Indicators	191
7-16	Japanese Composite Clock Input Module Configuration Settings	192
7-17	Pinout for the I-Port Input Adapter	193
7-18	Pinout for the 3-Port Input Adapter	194
7-19	Input Wire-Wrap Adapters	195
8-1	E1 Output Module Status LED Indicators	200
8-2	E1 Output Module Performance Specifications	201
8-3	DS1 Output Module Status LED Indicators	203
8-4	DS1 Output Module Performance Specifications	204
8-5	Composite Clock Output Module Status LED Indicators	207
8-6	Composite Clock Output Module Performance Specifications	208
8-7	Japanese Composite Clock Output Module Status LED Indicators	211
8-8	Japanese Composite Clock Output Module Configuration Settings	212
8-9	Identifying Failed Ports From The Hex Digit	215
8-10	Japanese Sine Wave Output Module Status LED Indicators	218
8-11	Japanese Sine Wave Output Module Configuration Data	219
8-12	Identifying Failed Ports from the Hex Digit	222
8-13	E1/2048 kHz Output Module Status LED Indicators	225
8-14	E1/2048 kHz Output Module Specifications	226
8-15	Identifying Failed Ports from the Hex Digit	230
8-16	2048 kHz Output Module Status LED Indicators	232
8-17	2048 kHz Output Module Specifications	232
8-18	Identifying Failed Ports from the Hex Digit	236
8-19	RS-422 Output Module Status LED Indicators	238
8-20	RS-422 Output Module Performance Specifications	238
8-21	LRM Kits	240
8-22	DS1 LRU Module Status LED Indicators	244
8-23	SSU-2000 and CTA I/O Pin Description	250
8-24	Line Re-timing Module Specifications	252
8-25	Status LED Indicators on the E1 LRU	256
8-26	E1 Line Re-timing Module Specifications	258
8-27	Buffer Module LED Indicators	260
8-28	Adapter Cables	262
9-1	Minimum Software Versions for Subtending Operation	272
9-2	Files Required for Upgrading the Firmware	273
9-3	SSU-2000 System Components	275

How to Use This Guide

This section describes the format, layout, and purpose of this guide.

In This Preface

- [Purpose of This Guide](#)
- [Who Should Read This Guide](#)
- [Structure of This Guide](#)
- [Conventions Used in This Guide](#)
- [Warnings, Cautions, Recommendations, and Notes](#)
- [Related Documents and Information](#)
- [Where to Find Answers to Product and Document Questions](#)
- [What's New in This Document](#)

Purpose of This Guide

The *SSU-2000 User's Guide* describes the procedures for unpacking, installing, using, maintaining, and troubleshooting the Symmetricom SSU-2000 Synchronization Supply Unit. It also includes appendixes that describe default alarms and events, the languages you use to communicate with the SSU-2000, default values, and other information.

Who Should Read This Guide

[Chapter 1, Product Overview](#), is written for non-technical audiences who need general information about the product. [Chapter 2, Installing the SSU-2000](#) and subsequent chapters contain technical information about the product. Other chapters and appendixes describe installation, maintenance, and configuration instructions or details primarily intended for qualified maintenance personnel.

This user guide is designed for the following categories of users:

- Systems Engineers – [Chapter 1](#) provides an introduction to the SSU-2000. Cross-references in this chapter direct you to detailed system information in other chapters as appropriate.
- Installation Engineers – [Chapter 2](#) through [Chapter 9](#) and the Appendixes provide detailed information and procedures to ensure proper installation, turn-up, operation, configuration, and testing of the SSU-2000.
- Maintenance Engineers – [Chapter 5](#) and the Appendixes provide preventive and corrective maintenance guidelines, as well as procedures for diagnosing and troubleshooting fault indications and alarms.

While [Chapter 1](#) is written for non-technical audiences who need information about the SSU-2000 system, others, such as [Chapter 2](#) through [Chapter 9](#) contain detailed information and instructions which are intended to be performed by *qualified personnel only*.

Structure of This Guide

This guide contains the following chapters and appendixes:

Chapter, Title	Description
Chapter 1, Product Overview	Provides an overview of the product and describes the major hardware and software features.
Chapter 2, Installing the SSU-2000	Contains procedures for unpacking and installing the product.
Chapter 3, Provisioning and Operating the SSU-2000	Describes the ICS and TL1 commands required to provision the SSU-2000 after installing the unit.
Chapter 4, Commissioning	Provides checklist-based commissioning tests that should be performed after completing turn-up and software configuration to ensure the system is ready for normal operation.
Chapter 5, Maintenance and Troubleshooting	Contains preventive and corrective maintenance, and troubleshooting procedures for the product.
Chapter 6, Clock Module Reference Data	Provides detailed information on the Communications module and the various Clock modules available for use in the SSU-2000.
Chapter 7, Input Module Reference Data	Contains detailed information on the Input modules available for use in the SSU-2000.
Chapter 8, Output Module Reference Data	Describes the Output modules available for use in the SSU-2000 and the SDU-2000.
Chapter 9, Hardware Configuration Guide	Describes how to configure the SSU-2000 in several modes, and lists part numbers for shelves, modules, and accessories.
Index	Provides references to individual topics within this guide.

Conventions Used in This Guide

This guide uses the following conventions:

- **Acronyms and Abbreviations** – Terms are spelled out the first time they appear in text. Thereafter, only the acronym or abbreviation is used.
- **Revision Control** – The title page lists the printing date and versions of the product this guide describes.
- **Typographical Conventions** – This guide uses the typographical conventions described in the table below.

When text appears this way...	... it means:
<i>SSU-2000 User's Guide</i>	The title of a document.
SSU CRITICAL IOC1	An operating mode, alarm state, status, or chassis label.
Select File , Open ...	Click the Open option on the File menu.
Press Enter Press ;	A named keyboard key. The key name is shown as it appears on the keyboard. An explanation of the key's acronym or function immediately follows the first reference to the key, if required.
SSU Username :	Text in a source file or a system prompt or other text that appears on a screen.
PING STATUS	A command you enter at a system prompt or text you enter in response to a program prompt. You must enter commands for case-sensitive operating systems exactly as shown.
<i>A re-timing</i> application	A word or term being emphasized.
Symmetricon does not recommend...	A word or term given special emphasis.

Warnings, Cautions, Recommendations, and Notes

Warnings, Cautions, Recommendations, and Notes attract attention to essential or critical information in this guide. The types of information included in each are explained in the following examples.



Warning: To avoid serious personal injury or death, *do not* disregard warnings. All warnings use this symbol. Warnings are installation, operation, or maintenance procedures, practices, or statements, that if not strictly observed, may result in serious personal injury or even death.



Caution: To avoid personal injury, *do not* disregard cautions. All cautions use this symbol. Cautions are installation, operation, or maintenance procedures, practices, conditions, or statements, that if not strictly observed, may result in damage to, or destruction of, the equipment. Cautions are also used to indicate a long-term health hazard.



ESD Caution: To avoid personal injury and electrostatic discharge (ESD) damage to equipment, *do not* disregard ESD cautions. All ESD cautions use this symbol. ESD cautions are installation, operation, or maintenance procedures, practices, conditions, or statements that if not strictly observed, may result in possible personal injury, electrostatic discharge damage to, or destruction of, static sensitive components of the equipment.



Electrical Shock Caution: To avoid electrical shock and possible personal injury, do not disregard electrical shock cautions. All electrical shock cautions use this symbol. Electrical shock cautions are practices, procedures, or statements, that if not strictly observed, may result in possible personal injury, electrical shock damage to, or destruction of components of the equipment.



Recommendation: All recommendations use this symbol. Recommendations indicate manufacturer-tested methods or known functionality. Recommendations contain installation, operation, or maintenance procedures, practices, conditions, or statements, that provide important information for optimum performance results.



Note: All notes use this symbol. Notes contain installation, operation, or maintenance procedures, practices, conditions, or statements, that alert you to important information, which may make your task easier or increase your understanding.

Related Documents and Information

Other helpful documents and software tools are listed below. See your Symmetricom representative or sales office for a complete list of available documentation.

- *SynCraft* management software
 - TimePictra management software
-



Note: Symmetricom offers a number of applicable training courses designed to enhance product usability. Contact your local representative or sales office for a complete list of courses and outlines.

Where to Find Answers to Product and Document Questions

For additional information about the products described in this guide, please contact your Symmetricom representative or your local sales office. You can also contact us on the web at www.symmetricom.com.

What's New in This Document

Revision F of this guide contains the following new information:

- The appendices in Revision E have been placed in a new book, the *SSU-2000 Technical Reference*. All references have been updated.
- The security commands have been updated: see [Overview of the SSU-2000 Security System](#), on page 93.
- Added new user and security procedures in [Adding Users to the System](#), on page 96 and [Setting Security Parameters](#), on page 98.
- Revised the procedure for backing up and restoring configuration parameters in [Backing Up the Configuration](#), on page 115 and [Restoring the Configuration](#), on page 116.

Chapter 1 Product Overview

This chapter describes the SSU-2000, and provides a theory of operation for the unit. The SDU-2000 expansion shelf is introduced and described.

In This Chapter

- [Overview](#)
- [Typical System Configurations](#)
- [System Architecture](#)
- [System Components](#)
- [Communications Protocol](#)
- [Overview of SSU-2000 Operation](#)
- [Indicators and Controls](#)
- [SDU-2000 Synchronization Distribution Unit](#)

Overview

The SSU-2000 Synchronization Supply Unit (SSU-2000), shown in [Figure 1-1](#), is a high-performance, Synchronization Status Messaging (SSM)-compliant Timing Signal Generator (TSG) or Synchronization Supply Unit that provides network synchronization signals for the telephone and telecommunications industry.

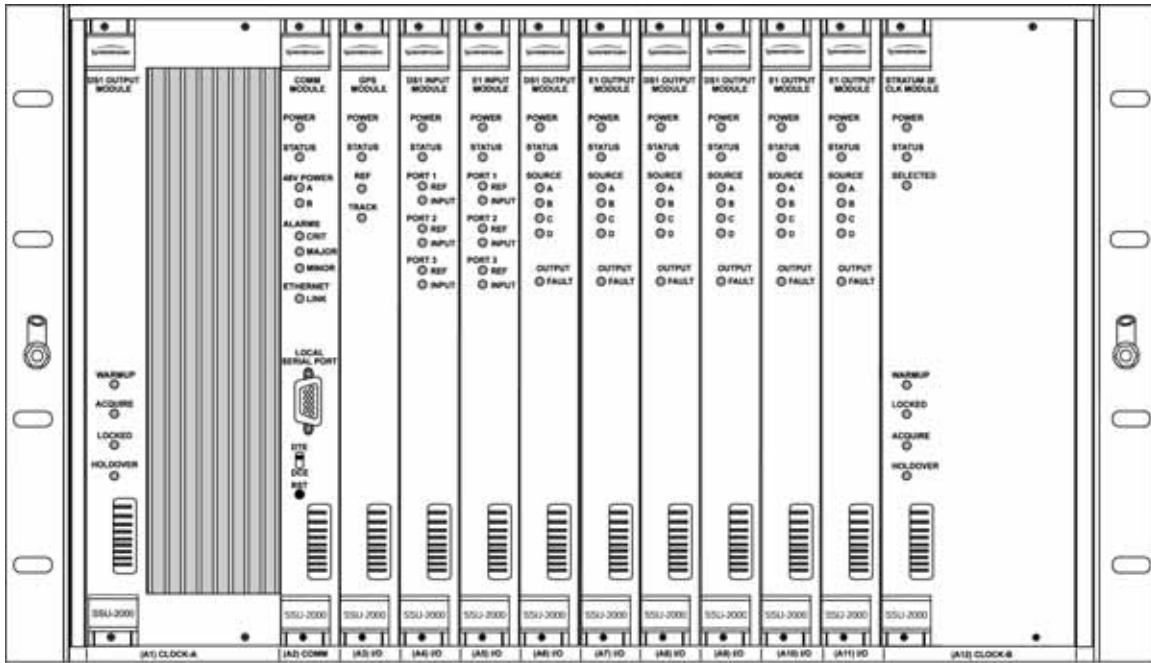

ss200006

Figure 1-1. SSU-2000 Synchronization Supply Unit

The SSU-2000 conforms to specifications for International, European and North American applications as a Primary Reference Source (PRS), and Synchronization Supply Unit (SSU), and Timing Signal Generator (TSG). The SSU-2000 allows for the integration of a variety of synchronization reference schemes including GPS and land line DS1/E1. The SSU-2000 meets or exceeds performance requirements for ANSI and Telcordia Technologies (Bellcore) Stratum 2 and ITU and ETSI Type II Transit Node clocks.

The SSU-2000 is designed to comply with the application flexibility and redundancy concepts introduced in Telcordia Technologies (formerly Bellcore) GR-2830. A selection of hot-swappable modules and powerful software allow users to easily reconfigure, upgrade, or expand the SSU-2000 to meet a variety of telecommunications synchronization application requirements.

The SSU-2000 fully supports Synchronization Status Messaging (SSM) as defined by ANSI, Telcordia Technologies, ITU, and ETSI.

The SSU-2000 is fully user-configurable and manageable through a software interface. Modules can be inserted or removed from the SSU-2000 while the system is operational without any degradation of output signals. Each module supports the management of critical, major and minor alarms, locally and remotely. Output modules and clock modules can be configured in redundant pairs, further increasing system availability.

The SSU-2000 has extensive event detection, reporting, alarming, and storage capabilities that permit monitoring of the system from external sites. Events are defined as changes in conditions within the unit, or at the interfaces of the unit, which may indicate abnormal operation or a change in the unit's operational status. For example, an event may be a parameter which exceeds a user-set threshold (usually 2 thresholds are provided). Each event can be assigned by the user to one of four modes, including IGNORE, REPORT, ALARM, or FAIL.

Typical System Configurations

The modular design of the SSU-2000 permits a great deal of flexibility in configuring the system components for a variety of applications. Three of the more common configurations include:

- Time Signal Generator (TSG) configuration
- Primary Reference Source (PRS) configuration
- Monitor-only configuration

Timing Signal Generator (TSG) Configuration

The Timing Signal Generator (TSG) configuration shown in [Figure 1-2](#) allows for input of external references to which the Clock modules are phase- and frequency-locked. This configuration allows for monitoring of several inputs, and for synchronization of output signals.

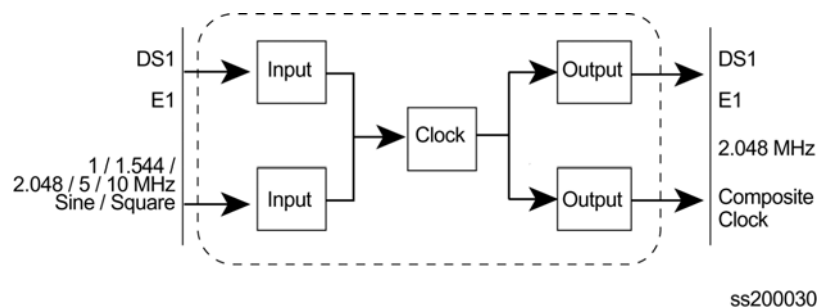

Figure 1-2. SSU-2000 Configured as a TSG

Primary Reference Source (PRS) Configuration

In a Primary Reference Source (PRS) configuration (Figure 1-3), the SSU-2000 meets the specifications defined in American National Standards Institute (ANSI) T1.101-1999. ANSI defines a Primary Reference Source as “equipment that provides a timing signal whose long term accuracy is maintained at 1×10^{-11} or better, with verification to Universal Coordinated Time (UTC), and whose timing signal may be used as the basis of reference for the control of other clocks within a network”. If standard Input modules are installed in the remaining input slots, this configuration also allows for monitoring of up to 24 external signals, such as DS1, E1, composite clock, and various clock frequencies. Time-of-day functionality is available through an Ethernet port employing NTP.

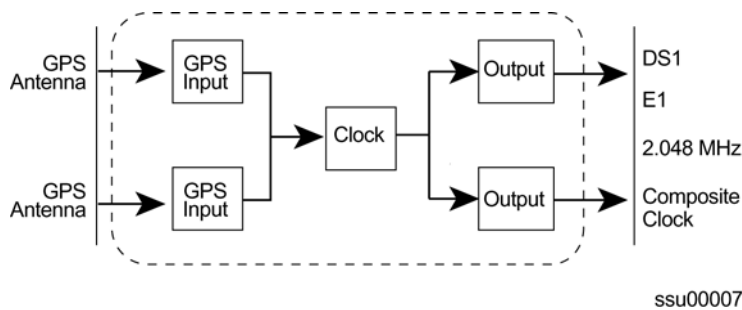

Figure 1-3. SSU-2000 Configured as a Primary Reference Source

SSU-2000 Configured as a Monitor-Only System

The SSU-2000 can also be configured as a monitor-only system (Figure 1-4) in which one of the inputs is designated as the reference, and a clock module is locked directly to this signal. The remaining input signals are then compared to the phase-locked oscillators (and indirectly to the designated input reference).

The SSU-2000 continuously monitors the integrity of the incoming timing signal. The operator defines input acceptance criteria and sets parameters for alarming. When the incoming signal is acceptable (within the performance limits set by the operator), the SSU-2000 phase-locks to the signal on a priority basis.

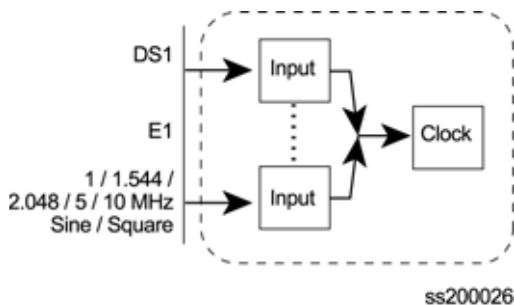

Figure 1-4. SSU-2000 Configured as a Monitor-Only System

System Architecture

The SSU-2000 system is a Timing Signal Generator that generates, monitors, controls, and distributes network synchronization signals. These signals can be DS1, E1, Composite Clock (CC), sinusoids, or square waves. The SSU-2000 continuously monitors incoming timing signal integrity. The operator defines input acceptance criteria and sets parameters for alarming. If a reference signal is acceptable (within the performance limits set by an operator), the SSU-2000 frequency-locks to the signal on a priority basis. System holdover and filtering performance is dependent on the quality of oscillators used in the SSU-2000's internal clock modules (Stratum 2E or Stratum 3E).

A selection of hot-swappable modules and powerful software allows users to easily configure, upgrade, or expand the SSU-2000 shelf to meet a variety of telecommunications synchronization application requirements. Modules can be inserted or removed from the SSU-2000 while the shelf is operational without any degradation of output signals. Each module supports the management of critical, major, and minor alarms. Output modules and clock modules can be configured in redundant pairs for increased reliability.

A simplified block diagram for the SSU-2000 is shown in [Figure 1-5](#).

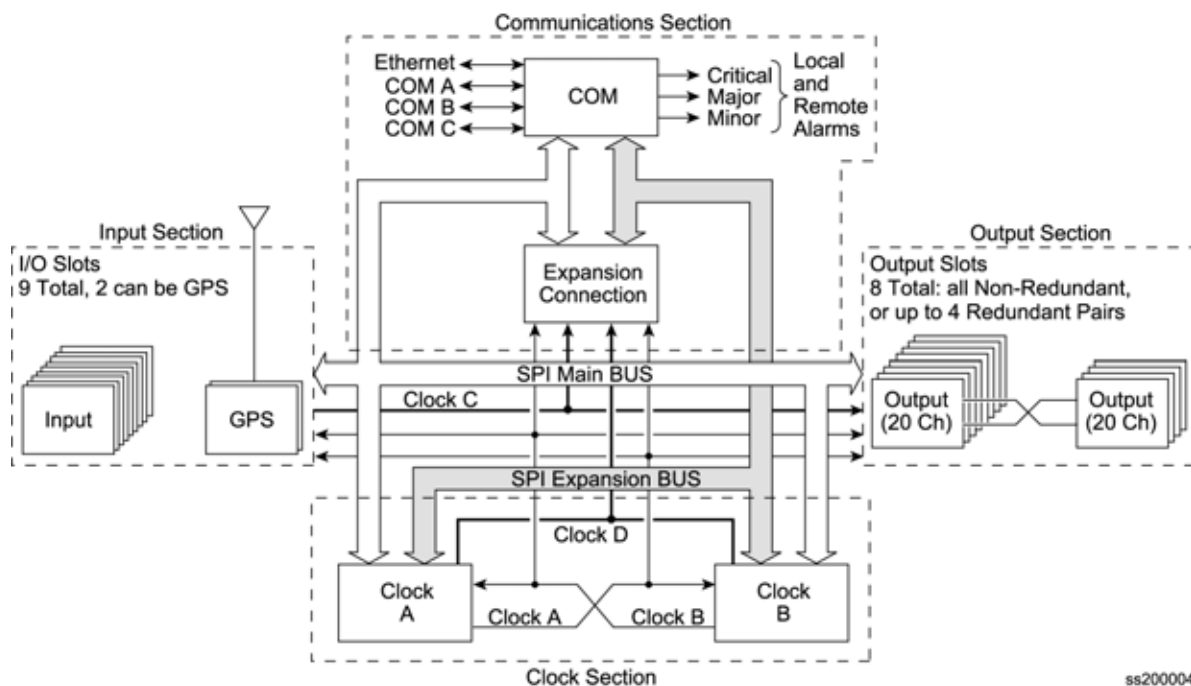

Figure 1-5. Block Diagram of the SSU-2000

As indicated in [Figure 1-5](#), the SSU-2000 consists of four major sections:

- Input section
- Clock section
- Output section
- Communications section

Input Section

The input section consists of one to nine Input modules to which you connect reference signals that are tested for signal integrity; the Input modules are described in [Chapter 7, Input Module Reference Data](#). You provision each input using the Interactive Command Set (ICS) INPUT and REF commands or the Transaction Language One (TL1) SET-PRMTR-INPUT and SET-INPUT-REF commands.

The Input modules measure the phase between the input signal and the clock oscillator(s). From these phase measurements, the DS1/E1 Input modules compute frequency offset and wander of the input signals. Wander is reported in terms of Maximum Time Interval Error (MTIE) and Time Deviation (TDEV). The data is then stored for use in the SSU-2000 and reported through the Communications module. You can install one or two GPS Input modules that use the satellite-based Global Positioning System signals as a synchronization reference. The Input signal types supported are:

- DS1/Clock (unframed)
- E1/Clock (unframed)
- GPS
- Composite Clock
- Japan Composite Clock
- Japan Sine Wave

Selecting the Input

Many factors influence which input reference the SSU-2000 uses:

- Priority
- PQL/SSM
- Switching mode
- User-assigned Input State
- Active alarms on an input

You can provision the SSU-2000 to automatically select the highest-quality input signal, or you can manually select the input signal you want to use. Two factors determine the quality of the input: the user-defined Priority level, and the PQL/ SSM. These factors are used to determine which input is used, and what happens if that input becomes disqualified.

Priority Level

You can assign a Priority level to each input; this value helps determine which input is used as the system reference. The range is 0 to 10; the lower the Priority level, the higher the priority. Use the TL1 command SET-PRMTR- INPUT or the ICS command INPUT to provision this parameter. See [Setting the Input Selection Mode](#), on page 30, for details on using the Priority level.

SSMs and Quality Level

Synchronization Status Messages (SSMs) may be included in the bit stream of the incoming signal to indicate its quality level. To read the incoming SSM, you must provision the input to read the SSM; for E1 signals, you must also provision the bit position of the incoming SSM. Use the TL1 command SET-PRMTR-INPUT or the ICS command INPUT to provision these parameters.

If the incoming signal does not include SSMs, or if you disable them, then you can provision the Quality Level to an appropriate value. The PQL value is used in the same manner as the incoming SSM to determine which input is used when the active input is disqualified. SSMs are described in more detail in [Synchronization Status Messages \(SSMs\)](#), on page 51.

Setting the Reference Switching Mode

Telcordia GR-378 and GR-1244 define two reference selection modes: Revertive and Non-revertive. In the Revertive mode, if an input used as the system reference is disqualified (for any reason), the reference switches to the next-highest input and reverts to the initial input when that input is re-qualified. In this mode, the reference switches two times: once when the disqualifying event occurs, and again when the initial input is re-qualified. In the Non-revertive mode, the system reference switches to the next-highest input but does not revert to the initial input when the initial input is re-qualified. The system reference switches only once when the disqualifying event occurs.

The ICS command REF and the TL1 command SET-INPUT-REF allows you to set the reference switching mode to AutoReturn, AutoSwitch, or OFF. The AutoReturn mode is Revertive, and enables automatic switching with automatic return to the input with the highest Priority or PQL level. The AutoSwitch mode is Non-revertive; the reference automatically switches to the next-highest input on failure of the selected input. When set to OFF, only manual switching is allowed. If the selected reference input is disqualified for any reason, the clock enters the Holdover mode and you must correct the fault and re-provision the reference input.

Setting the Input Selection Mode

The ICS command REF and the TL1 command SET-INPUT-REF determine what type of reference input selection and reference switching is used. You can set the input selection to either Priority or PQL. The reference switching mode is either Autoreturn, Autoswitch, or No switching.

After you select the reference switching mode, the Input module reads and processes the Priority level and PQL value to determine the traceability of inputs. This traceability information is then used by the Clock modules in selecting a reference signal and for embedding the SSM into the outputs.

If you select *Priority* mode, the SSU-2000 selects the input reference with the highest user-defined Priority setting; if all inputs have the same Priority level, then the input with the highest PQL (quality level, SSM) is used.

If you select *PQL* mode, the SSU-2000 selects the input reference with the highest assigned PQL level or associated SSM; if all inputs have the same PQL/SSM value, then the input with the highest Priority levels is used. In either case, error conditions such as Loss of Signal (LOS), Out of Frame (OOF), MTIE, TDEV, and Phase performance data collected at the inputs are used to disqualify inputs (prevent input selection) based on user defined thresholds.

In either mode, when the Priority and PQL values are equal for each input, the physical location of the Input module determines the priority for selecting the input reference. Port 1 on the Input module in the leftmost slot has the highest priority; the priority decreases to port 1 on the Input module in the rightmost slot. Port 2 on the module in the leftmost slot has the next lower priority, decreasing to Port 2 on the Input module in the rightmost slot. Port 3 on the module in the leftmost slot has the next lower priority, and Port 3 on the module in the rightmost slot has the lowest priority.

If the Input module is configured for provisioned mode, it reports the user-assigned SSM. If it is configured for automatic mode, the Input module uses the most recent valid SSM. If a valid SSM is not received, the module uses the user-assigned SSM.

Setting an Input Alarm Strategy

You can provision the SSU-2000 to elevate input alarms to the next higher level after a specified amount of time. You can also specify that an alarm clears automatically after a specified period of time without the alarm condition. For more information on alarms, see [Alarms and Events](#), on page 32.

Bypass Clock (Clock C)

In the event that both Clock modules fail, an input connected to a D1, E1, or Composite Clock Input module can serve as the system reference. The input must be a valid reference, and it must have a Priority setting. When the Bypass clock is the active reference, then the output signal is not filtered and any wander or jitter on the input signal appears on the outputs. The Bypass clock is intended only for short-term use; you should resolve the failures on the Clock modules as quickly as possible.

Output Section

The output section contains from one to six (three redundant pairs) Output modules in the main shelf and up to 56 (28 redundant pairs) Output modules in a fully expanded system with four SDU-2000 expansion shelves. Each Output module type provides 20 independent output synchronization signals. Output modules are available to support the following formats:

- DS1, SF (D4) and ESF
- E1
- 2048 kHz
- Composite Clock (CC) (64/8 kHz)
- Other typical clock frequencies

Clock Section

The clock section consists of one or two Clock modules that provide the internal reference signals for generating TSG output timing signals. The primary Clock module (Clock A) is configured as the master clock and is normally a higher stratum level than the back-up clock (Clock B). If a problem occurs in Clock A, the control is automatically passed to the back-up Clock module (Clock B). The frequency of each clock is locked to a valid reference input signal (one that is free from input faults while meeting acceptable frequency and MTIE specifications).

The SSU-2000 controls clock frequency by adjusting the control value of the Direct Digital Synthesis (DDS) function in each Clock module. The adjustments are processor-controlled and based on measurements performed and computed in the Input module(s). Clock modules may be Type I, Stratum 2E, or Stratum 3E. Outputs are maintained by the active input reference signal if both clocks should ever fail or be removed from the system.

Communications Section

The Communications section consists of one Communications module, which contains hardware and software that allows the user to configure, monitor, and control the SSU-2000 system and generate local and remote alarms when fault conditions are detected. The SSU-2000 can continue to function seamlessly without the Communications module (Clock modules assume the system controller function), but all communications and alarm reporting functions are interrupted.

The master controller function for the SSU-2000 can reside in either the Communications module or in either of the clock modules. The priority of the selection of the module that will provide the master controller function rests with the Communications module, Clock A, and Clock B, in that order. In the event of removal of the module designated as the master controller, that function automatically and seamlessly switches to the next module in priority order.

The Communications module communicates with the other modules in the SSU-2000 to read configuration data, set operational parameters, and determine what type of modules are installed. When a module is replaced, the controller loads the correct operational parameters into the replacement module.

The Communications module provides an interface between the user and the SSU-2000 system. This interface allows the user to display and control much of the activity in the SSU-2000 system and within the optional SDU-2000 expansion system. The Communications module supports three serial ports and one Ethernet port, and allows communication over each of them independently in one of several possible modes (ASCII, TL1, or packet).

The software in the Communications module allows for on-site reprogramming of the flash ROM and reconfiguration of all programmable logic devices. The Communications module also allows for this same capability for the input and clock modules. The software on all other module types installed in the SSU-2000 system can be updated by downloading it through the Communications module.

When the Communications module is installed, it performs an initial software verification test to verify operation. If the module is installed in the SSU-2000 with power already applied and with other modules installed, the Communications module reads the configuration of the modules in the SSU-2000 and the modules in all installed SDU-2000 expansion shelves. This information is saved in nonvolatile memory in the Communications module. If power is applied to the SSU-2000 after the Communications module is installed, it initializes before of any of the other modules and provides configuration information to the individual modules.



Note: The Clock modules also store configuration information and can download this information to the various modules if the Communications module is removed from the shelf.

Alarms and Events

The SSU-2000 has extensive event detection, reporting, and alarm generation and storage capabilities that permit monitoring of the system from external sites.

Alarms are conditions within the unit or at the interfaces of the unit which may indicate abnormal operation or a change in the unit's operational status. For example, an alarm may be generated when a parameter which exceeds a user-set threshold. Most alarms can be assigned by the user to one of the following modes: IGNORE, REPORT, MINOR, MAJOR, or CRITICAL.

All Alarms detected in the SSU-2000 system are reported by three methods, including:

- Display on the module LEDs
- Relay contact closures on the rear panel of the SSU-2000 main shelf
- Messages transmitted on all communications ports

All Alarm indications clear when the condition(s) that caused them no longer exist. In a case where a module in alarm is unplugged from the system, a command must be issued to clear the module's active alarms. In addition, normal operating status is indicated by green LEDs on the modules.

Events are conditions within the unit, or at the interfaces of the unit, which may indicate abnormal operation or a change in the unit's operational status. Recurring events may be escalated to alarm status and may require action by the user. Conversely, alarms may be de-escalated and corrected automatically. See the *SSU-2000 Technical Reference* for details.

Although every alarm is considered to be an event, not every event is an alarm. For example, a *login* is recorded as an event but is not considered to be an alarm. In this case, no action is required by the user.

Ignore Mode

IGNORE means that appropriate information on the event is transmitted on all of the communications ports when the event occurs, and on demand, but no alarm is generated. For example, the status of the SSM at each input port and at the output ports is reported when it changes and when the user sends an inquiry but no alarm is generated.

Report Mode

The REPORT mode option is used to report alarm indications only.

An ALARM command is available in the SSU-2000 that allows a user to view the current status of alarm indications on the unit and set alarm delay intervals and activation levels. Only active alarm indications are displayed unless an option is specified.

The DELAY option sets the length of time in seconds an alarm must be active before generating a hardware indication. This option also allows the user to set the level of any alarms:

- **IGNORE** – ignore any alarm indication
- **REPORT** – report only alarm indications
- **MINOR** – sets alarm level to MINOR
- **MAJOR** – sets alarm level to MAJOR
- **CRITICAL** – sets alarm level to CRITICAL

See the *SSU-2000 Technical Reference* for information on the DELAY option.

Alarm Mode

The user sets an alarm to one of three levels of alarm severity: MINOR, MAJOR or CRITICAL. In general, events which are classified as ALARMS are those for which user intervention is required. MINOR and MAJOR alarms can be elevated automatically to the next higher level after a user-set time period.

Input ports are disqualified as a possible system reference when their alarm level is Major or Critical. The SSU-2000 switches to a redundant module or component when the currently-active module or component has a Major or Critical alarm. For example, an active Clock module with a Major or Critical alarm causes the secondary Clock module to become the active Clock module.

The unit is capable of generating reports to include: local oscillator being switched, log in/out, restart, board removed/inserted, events cleared, PLL loop control, user image clear/set, phase samples, frequency control, and a keep alive output every 5 minutes. See the *SSU-2000 Technical Reference* for information on commands.

Alarms and all events are reported over the communication ports and contain details of the event in a single message including the time of the event. All ALARM indications clear when the conditions that caused them no longer exist. In addition, normal operating status is indicated by green LEDs on the front panel of modules.

Fail Mode

In the FAIL mode, the SSU-2000 removes the failed module from service or usability to prevent interruption of the system. For example, a FAIL event detected in Clock A causes a switchover from Clock A to Clock B, effectively removing Clock A from the system. The FAIL event is reported on all communications ports and an alarm is generated.

System Components

A fully expanded SSU-2000 installation contains the following physical components:

- SSU-2000 Main shelf populated with various combinations of Clock, Input, Output and Communications modules
- Input and Output Adapter panels
- Up to four SDU-2000 Expansion shelves containing Buffer and Output modules



Note: For additional information about each of the module types, see [Chapter 6, Clock Module Reference Data](#), [Chapter 7, Input Module Reference Data](#), and [Chapter 8, Output Module Reference Data](#). See [Chapter 9, Hardware Configuration Guide](#), for component part numbers and guidelines for configuring a new system.

SSU-2000 Main Shelf (Chassis)

The SSU-2000 main shelf (shown in [Figure 1-6](#)) contains a metal chassis and a motherboard with provisions for supporting up to 12 hot-swappable modules. Filler panels are available for use in shelves that are not fully populated.

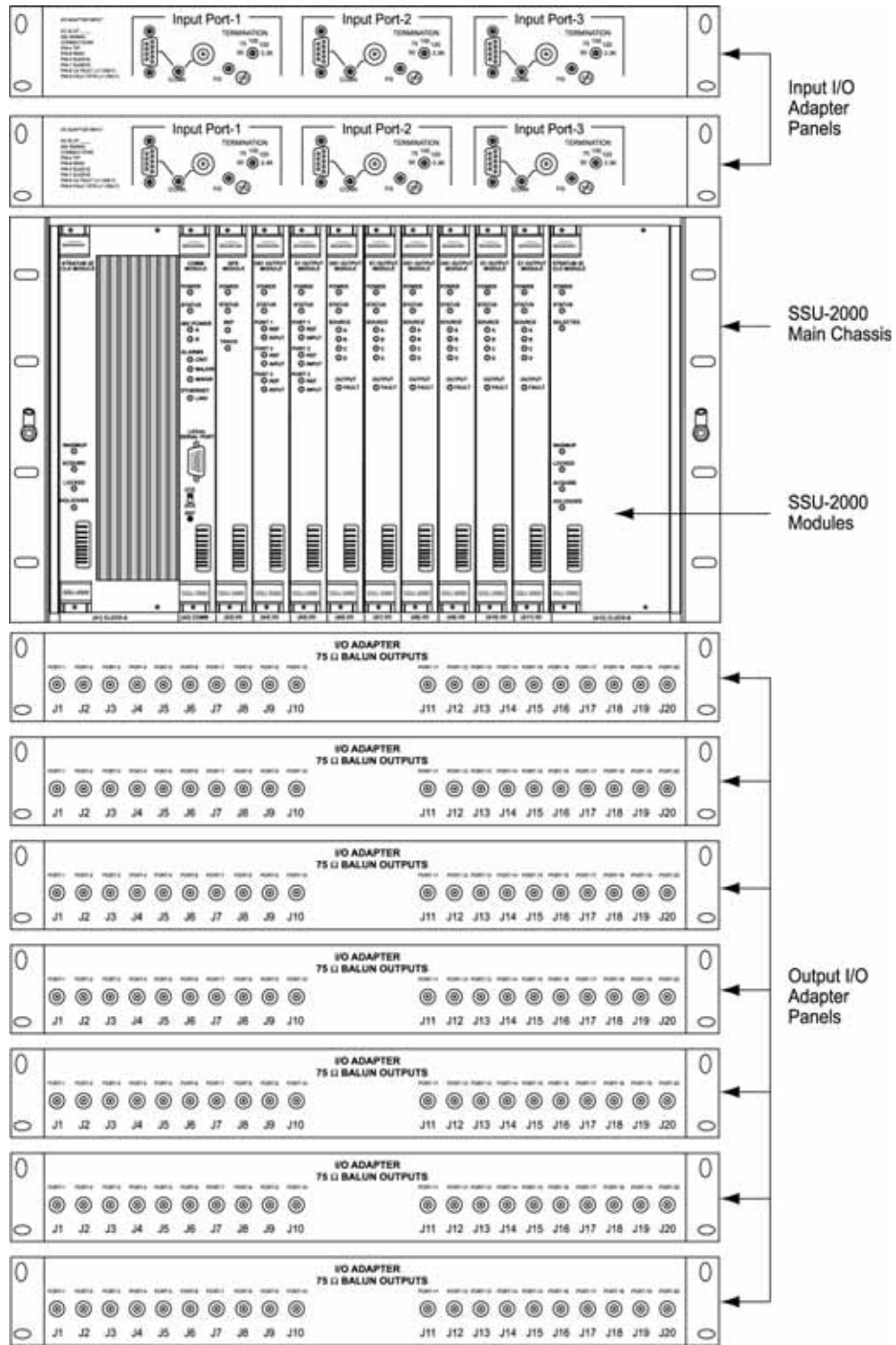

ss200007

Figure 1-6. Components in a Typical SSU-2000 Installation

Module Assignments

All SSU-2000 modules are equipped with card ejectors and plug in from the front of the shelf. Each module is secured in the shelf with captive fasteners. The module assignments for the SSU-2000 main shelf are listed in [Table 1-1](#) and are shown in [Figure 1-7](#).

Table 1-1. Slot Assignments for Specific Modules

Slot	Module
A1	Clock Module A
A2	Communications Module
A3-A11	Input or Output Modules
A12	Clock Module B

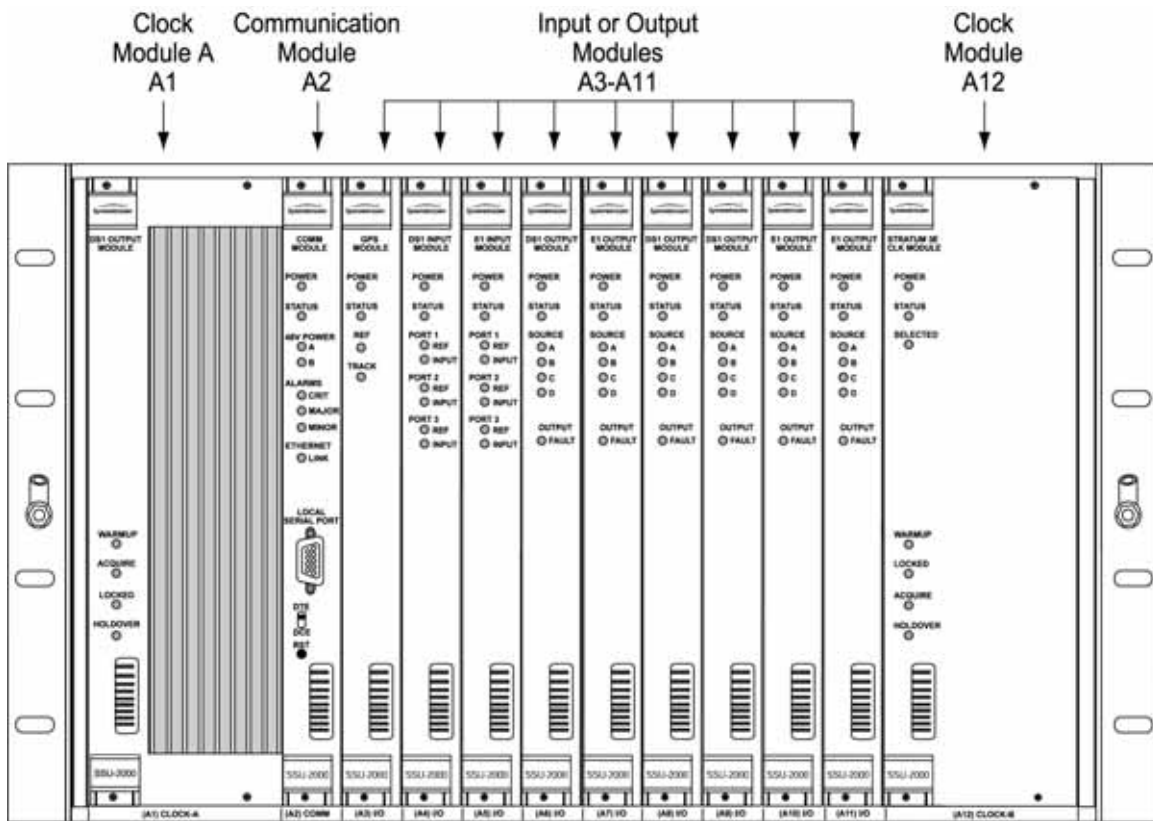

ss200008

Figure 1-7. Slot Numbering Assignments

As indicated in [Figure 1-7](#), the SSU-2000 modules are installed in slots A1 through A12, numbered left to right as viewed from the front of the shelf. The first or left-most slot, A1, is assigned to the primary clock module (Clock A). Slot A2 is assigned to the Communications module and slots A3 through A11 are assigned to various combinations of input modules and output modules. Slot A12 is reserved for the secondary clock module (Clock B).

Main Shelf Connections

The rear panel of the main shelf contains the connection terminal strips, BNC connectors, and SCSI-II connectors that are used to connect the SSU-2000 to other system components. These connection features are described in [Figure 1-8](#).

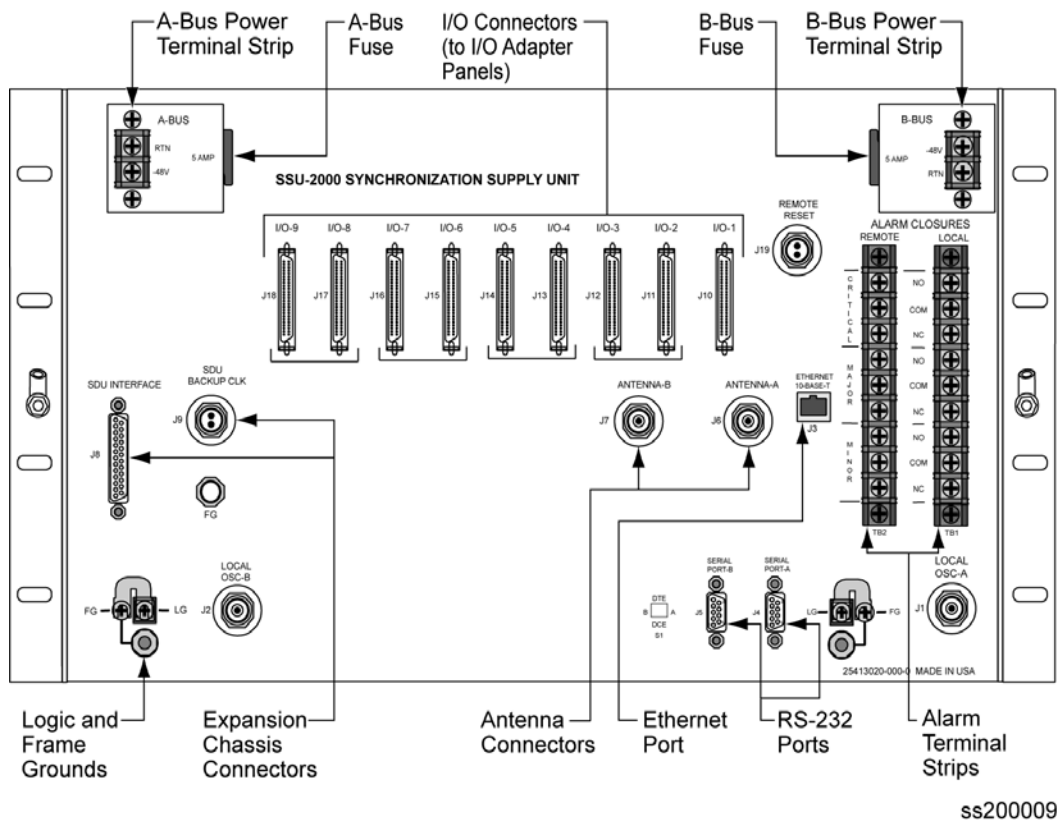

Figure 1-8. Rear Panel of the SSU-2000 Main Shelf

The SSU-2000 main shelf connection features include:

- I/O connectors (I/O-1 through I/O-9)- 50-Pin, Micro-D female connectors (SCSI-II type) used for connecting the I/O adapter panels to the SSU-2000. Each I/O connector is associated with a specific I/O module slot. I/O adapter panels are available to convert the 50-Pin, Micro-D female connectors to telecommunications standard Balun (balanced/unbalanced) or DE9 connectors, see the *SSU-2000 Technical Reference* for additional details
- Dual set of power terminals and dual set of grounding lugs for connecting external power and grounding to the SSU-2000 system

- Three communications ports including two serial port connections (Serial Port-A and Serial Port-B) and one RJ-45 Ethernet connector (Ethernet 10-Base-T). Another serial communication port is also available on the front of the Communications module
- DTE/DCE switch is a slide switch (S1) that allows the user to select either a DTE or DCE serial port interface.
- Reference inputs and clock outputs
- Local and remote alarm contact closures, divided into three classes:
 - CRITICAL Alarms – Indicates an immediate service-affecting condition that requires immediate user intervention (such as loss of Communications module, loss of input power to the shelf, etc.). When a critical alarm condition is detected, the CRITICAL ALARM relay is activated (alarm condition) and the CRITICAL ALARM LED on the front of the Communications module lights red unless power was interrupted. In this case the unit no longer has power.
 - MAJOR Alarms – Indicates a condition that may require immediate user intervention. When a major alarm condition is detected, the major alarm relay on the rear panel of the SSU-2000 is activated and the MAJOR ALARM LED on the front of the Communications module lights red.
 - MINOR Alarms – Indicates that the unit performance is degrading. The minor relay is activated and the MINOR ALARM indicator lights.
- Two local oscillator connections – Local OSC-A and Local OSC-B are normally used as outputs to feed other equipment but can also be used as inputs when the shelf is configured with plug-in modules as a monitor only.
- Two antenna connectors – used to attach radio receiver antennas. The A antenna connector (J6) connects to slot 1A3; the B antenna connector (J7) connects to slot 1A5.
- Interface connector for the optional SDU-2000 Synchronization Distribution Unit (output signal expansion system). Up to four expansion shelf can be connected in daisy-chain fashion to an SSU-2000 shelf. A termination plug must be installed on this connector if not using the expansion shelf.
- SDU Backup Clock (D-clock) that can be used in the expansion shelf in the event of the loss of clock A or B. The shelf also has optional rack mounting ears for mounting in 19 inch EIA, 23 inch EIA and AT&T, and ETSI racks and cabinets.

Main Shelf Power Distribution

The main shelf accepts redundant –48 VDC power inputs from external supplies and makes these inputs available to the modules via the motherboard connectors anytime the 5-Amp fuses are installed on the rear of the SSU-2000 main shelf.

An On/Off switch is not provided, preventing anyone from accidentally shutting down the system. To shut down the system, the two fuses (Power Supply A and Power Supply B fuses) must be physically removed from the rear panel of the shelf (see [Figure 1-9](#)). If only one fuse is removed, the system senses the loss of the power input and switches to the second power input.

All power supplies for the SSU-2000 are implemented on the individual modules which increases system availability by eliminating a single point of failure in the power supply area. On each plug in module, diodes combine the two power sources and provide protection from reversal of the power connections on the shelf (+ and – reversed). Screw type lugs on the rear of the shelf are used for logic and shelf ground connections.

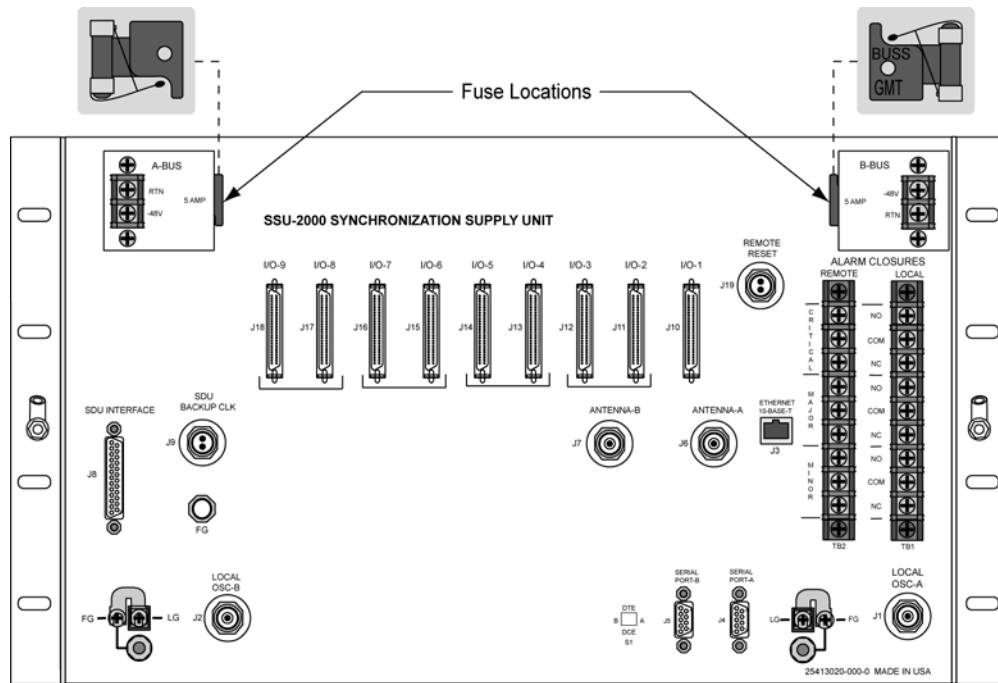

ss200003

Figure 1-9. Location of Power Fuses on the Rear Panel

Antenna Connectors

The SSU-2000 contains two TNC connectors to allow for connection of a radio antenna. Connector J6 is wired into I/O slot A3 and connector J7 is wired into I/O slot A5 (the only slots that can be used for installing a Radio input module). A variety of GPS antennas are available as accessories, see the *SSU-2000 Technical Reference*.

Communication Ports

The SSU-2000 main shelf contains four communication ports, including:

- Two RS-232 communication ports (Port A and Port B) on the rear panel of the main shelf
- One RS-232 port on the face of the Communications module (Port C)
- One RJ-45 Ethernet connector on the rear panel of the SSU-2000 (Ethernet 10-Base-T) for network connection

A user interface (software residing in the Communications module) provides various levels of password-protected access for configuration, detailed performance monitoring, and diagnostics. Refer to the *SSU-2000 Technical Reference* for more information on configuration and detailed performance monitoring. Remote EIA-232-C ports can be assigned their own interface type, either Interactive Command Set (ICS) or TL1 that is retained in NVRAM. The Local port (Port C on the Communications module) is always in ICS mode when the Communications module restarts.

Main Shelf Power Connections

The SSU-2000 main shelf contains provisions for connecting redundant –48 VDC external power inputs (designated A and B input power). The power supplies, located on the internal modules, can accept input power in the range of –37 to –72 VDC.

Each power input to the main shelf is accomplished using a 2-connection terminal strip, with the negative side fused. Both connections are isolated from frame and signal grounds. In the event of the loss of either the A or B input, the system senses the loss of power, reports the loss of the power input and continues normal operation on the remaining power input. If both power supply inputs are lost, the Critical Alarm relay de-energizes to the alarm state and a Critical alarm is reported.

Main Shelf Frame/Logic Grounds

Screw type lugs on the rear of the shelf are used for logic and shelf ground connections. Grounding for integrated or isolated ground planes are supported by two user-configured hardware straps.

SSU-2000 Family of Modules

The SSU-2000 family of modules includes the following:

- Stratum 2E Clock Module
- Stratum 3E Clock Module
- Type 1 Clock Module
- Communications Module
- 1-Port and 3-Port E1 Input Modules
- 1-Port and 3-Port DS1 Input Modules
- Composite Clock Input Module
- Japan Sine Input Module
- Japan Composite Clock Input Module
- GPS Input Module
- 2048 kHz Output Module
- RS-422 Output Module

- E1 Output Module
- DS1 Output Module
- Composite Clock Output Module
- Japan Sine Output Module
- Japan Composite Clock Output Module
- DS1 Line Re-Timing Module
- E1 Line Re-Timing Module

Some of the features common to all modules include:

- Any module can be inserted or removed while power is applied without affecting the operation of other modules in the system.
- All modules are individually fused to protect the system in case of a short circuit on any one module.
- All modules have front panel status LEDs.
- All modules are equipped with ejector tabs for ease of installation and removal and secured in place with captured screws to provide module security and reduce the occurrence of unauthorized removal.
- All SSU-2000 modules (except the Buffer module) have an integrated CPU with firmware and are software configurable.

Each module slot also has three pins connected together on its assigned Hybrid DIN connector which permits the system to detect when a particular module is removed. More information is available for each of these modules in [Chapter 7, Input Module Reference Data](#).

Clock and Communications Modules

Stratum 2E Clock Module

The Stratum 2E Clock module uses a Rubidium oscillator and meets the requirements of ANSI and Telcordia Industries (Bellcore) for Stratum 2 clocks. This clock also meets the ITU-T and ETSI specifications for Type II Transit Node clocks.

The module reads measurement data from the input modules, provide frequency control of its oscillator through DDS circuitry, and generates a reference signal used by the input and output modules. The clock module also maintains phase synchronization with the redundant clock module. For more information, see [Stratum 2E Clock Module](#), on page 138.

Stratum 3E Clock Module

The Stratum 3E Clock module meets or exceeds performance requirements for ANSI and Bellcore Stratum 3E and ITU and ETSI Type III Local Node clocks.

The Stratum 3E Clock Module reads measurement data from the Input modules, provide frequency control of the oscillators through DDS circuitry, and generates a reference signal used by the Input and Output modules. The Clock module maintains phase synchronization with the redundant Clock module. Its hardware and software also provides for temperature compensation, aging compensation for quartz oscillators, an initial offset adjustment, and frequency adjustment resolution of 1×10^{-13} or better. For more information, see [Stratum 3E Clock Module](#), on page 142.

Type 1 Clock Module

The Type I Clock module uses a quartz oscillator which meets or exceeds the performance requirements for ITU and ETSI Type I Slave clocks.

The Type I Clock module reads measurement data from the Input modules, provides frequency control of the oscillator through DDS circuitry, and generates reference signals used by the Input and Output modules. For more information, see [Type 1 Clock Module](#), on page 146.

Communications Module

The Communications module serves as the user interface to the SSU-2000. The module command interface supports three EIA-232-C connections and one Ethernet interface for communication with the SSU-2000 system. This module also logs the unit events into non-volatile memory for inspection at a later date and reports alarms as they occur. For more information, see [Communications Module](#), on page 150.

Input Modules

1-Port and 3-Port DS1/E1 Input Modules

The DS1 and E1 Input modules are available with both 1-Port and 3-Port configurations. These modules receive signals and perform phase measurement comparisons with the Clock modules that are installed in the SSU-2000. The Clock modules use this information to phase and frequency lock to the incoming signal. The data may also be used for monitoring the frequency of incoming signals.

The DS1 and E1 Input modules accept the following signals: sine or square wave (with frequency of 1, 1.544, 2.048, 5 or 10 MHz) or framed communications type DS1 or E1. If the input signal is a communications type, the module monitors the following errors:

- Alarm Indication Signaling (AIS)
- Bipolar Violations (BPV)
- Cyclic Redundancy Check (CRC)
- Loss of Signal (LOS)
- Out Of Frame (OOF)

The module also extracts Synchronization Status Messages (SSM) from incoming data. For more information, see [1-Port and 3-Port E1 Input Modules](#), on page 158, and [1-Port and 3-Port DS1 Input Modules](#), on page 167.

GPS Input Module

The GPS Input module is a one-port card that can only be installed in the SSU-2000 main shelf. The module is used to correct the frequency of the oscillator on the Clock module. It monitors and reports the status and performance of the module and radio signals that it receives. See [GPS Input Module](#), on page 176, for more information.

You must install this module in slot A3 or A5; the antenna connectors J6 and J7 on the rear panel are connected to these slots, respectively.

Composite Clock Input Module

The Composite Clock Input module conditions a composite clock input signal that is used to control the frequency of the Clock modules. For more information, see [Composite Clock Input Module](#), on page 179.

When the SSU-2000 is in the Subtending mode, the module also produces a 4 kHz synchronization signal that determines the phase of the composite clock signals generated by Composite Clock Output modules. This signal ensures that the phase of the composite clock output signals follows the phase of the composite clock input reference signal.

Japanese Sine Input Module

The J/SW Input module accepts up to three input signals of either 1.544 MHz or 6.312 MHz and performs phase measurement comparisons (at a sampling rate of 40 Hz) with the Clock modules. The Clock modules use this information to phase and frequency lock to the incoming signal. The data can also be used for monitoring the frequency of incoming signals.

For more information on this module, see [Japanese Sine Wave Input Module](#), on page 182.

Japanese Composite Clock Input Module

The J/CC Input module conditions a composite clock input signal that is used to control the frequency of the Clock modules. For more information, see [Japanese Composite Clock Input Module](#), on page 189.

If the Input module is provisioned to receive an input with a 400 Hz component and the 400 Hz is available on the input signal, the JCC4 outputs are aligned to the 400 Hz. When the SSU-2000 is in the Subtending mode, it also produces a 4 kHz synchronization signal that determines the phase of the composite clock signals generated by Japanese Composite Clock Output modules. This signal ensures that the phase of the composite clock output signal follows the phase of the composite clock input reference signal.

Output Modules

E1 Output Module

The E1 Output module uses one of three 4 kHz clocks from the SSU-2000 main shelf backplane to generate a phase-locked signal of 2.048 MHz. If the unit is inserted into an SDU-2000 expansion shelf, a fourth 4 kHz clock (D clock) is available. The phase-locked 2.048 MHz signal is used to generate a set of 20 output signals for distribution to large networks. See [E1 Output Module](#), on page 198, for more information.

DS1 Output Module

The DS1 Output module generates a phase-locked signal of 1.544 MHz using one of three 4 kHz clocks from the backplane of the SSU-2000 main shelf. If the module is inserted into the SDU-2000 Synchronization Distribution Unit (expansion shelf), a fourth 4 kHz clock is available. The phase-locked signal generates a set of 20 output signals for distribution to large networks. [DS1 Output Module](#), on page 202, contains detailed information on the module.

Composite Clock Output Module

The Composite Clock (CC) Output module can be installed in the SSU-2000 to generate and monitor CC signals, monitor input reference signals, accept new configuration data, and report status. This module provides 20 signal pairs (TTIP and TRING signal pairs), which are referenced to the selected clock signal. For more information, see [Composite Clock Output Module](#), on page 205.

E1/2048 kHz Output Module

The E1/2048 kHz Output module can be installed in the SSU-2000 to generate and monitor 20 independent E1/2048kHz output signals. If the module is inserted into an SDU-2000 expansion shelf, a fourth 4 kHz clock (D clock) is available. If the input signal PQL drops below a user-specified level, then the outputs can be squelched. For more information, see [E1/2048 kHz Output Module](#), on page 219.

2048 kHz Output Module

The 2048 kHz Output module plugs into selected input/output slots in the SSU-2000 main shelf or one of the output slots on the expansion shelf. The module generates and monitors 20 independent 2048 kHz signals that are referenced to a selected clock module. The 2048 kHz Output module receives a set of three (four if installed in an expansion shelf) 4 kHz clocks from the Clock modules and uses these clocks to develop an 8.192 MHz phase-locked signal. This phase-locked signal is then used to generate 20 sets of 2048 kHz clock outputs. For more information, see [2048 kHz Output Module](#), on page 227.

RS-422 Output Module

The RS-422 Output module generates 10 balanced square-wave outputs (TTIP and TRING signal pairs) and 10 single-ended (Ring) square-wave outputs. Each output can be turned off independently of other ports; relays on each output disconnect the driver output from the output pins. A squelch feature turns off selected ports when the input signal falls below predetermined quality levels. See [RS-422 Output Module](#), on page 233.

Japanese Composite Clock Output Module

The J/CC Output module generates 20 non-summable signal pairs (TTIP and TRING signal pairs). Each output is a transformer-coupled symmetrical pair. Each output pair can be turned off independently of other channels. These outputs are independently configurable for phase delay from 0 to 3.4 μ s in 8 steps.

In subtending mode, the Output module's signals are byte and polarity phase aligned with the 4 kHz clock signal from the Japanese Composite Clock Input module. This 4 kHz clock signal ensures that the phase of the composite clock output signal follows the phase of the composite clock input reference signal. See [Japanese Sine Wave Output Module](#), on page 213 for more information.

Japanese Sine Wave Output Module

The J/SW Output module uses one of three 4 kHz clocks from the SSU-2000 main chassis backplane to generate a phase-locked reference signal for the synchronized clock output signals. The phase-locked signal is used to generate 20 software selectable outputs of either 6.312 MHz or 1.544 MHz for distribution to large networks. See [Japanese Sine Wave Output Module](#), on page 213 for more information.

Line Re-timing Unit (LRU)

Symmetricon offers two Line Re-timing modules for the SSU-2000: one for DS1 signals and one for E1 signals. The LRU is comprised of a Line Re-timing module (LRM) and a Cut-Through Assembly (CTA). The DS1 LRU is available in both a two-port (dual) and four-port (quad) version. The E1 LRU is available in a four-port (quad) version. For more information, see [DS1 Line Retiming Unit \(LRU\)](#), on page 240 and [E1 Line Re-timing Unit](#), on page 253.

The DS1 LRU inserts DS1 signals on both sides of a DSX-1 panel in a Central Office. Side 1 of the DS1 re-timer provides "3R" (Re-shape, Re-amplify, and Re-time) for the DS1 signal to a client Network Element. When the LRU receives a DS1 data stream, it re-times the data with the transmit clock signal. The clock signal is inserted into the DS1 line route between two DS1 path-terminating elements. Side one is the direction in which timing is applied. Side 1 contains the DS1 line performance reporting and AIS generator. AIS is not generated when the port is set to Unused/Off. Side 2 provides "2R", which Re-shapes and Re-amplifies (regenerates) the DS1 signal from the client Network Element. Side 2 does not provide performance monitoring or AIS generation.

The E1 LRU provides four independent retimed lines (signals) and automatically detects framing, and can be provisioned for AMI or HDB3 codes. The LRM inserts E1 signals on both sides of a system connectivity panel in a Central Office. Side 1 of the E1 re-timer provides "3R" (Re-shape, Re-amplify, and Re-time) for the E1 signal to a client Network Element.

When the LRM receives an E1 data stream, it re-times the data with the transmit clock signal. The clock signal is inserted into the E1 line route between two E1 path-terminating elements. Side 1 is the direction in which timing is applied, and contains the E1 line performance reporting and AIS generator. AIS is not generated when the port is set to Unused/Off. Side 2 provides “2R”, which Re-shapes and Re-amplifies (regenerates) the E1 signal from the client Network Element. Side 2 does not provide performance monitoring or AIS generation.

Configuring Redundant Output Modules

For an A/B pair of Output modules (in a redundancy configuration), it is possible to connect all of the outputs of Module B to the corresponding outputs of Module A, providing 1:1 output protection (1:1 redundancy). [Figure 1-10](#) shows the SSU-2000 input/output connectors.

This requires the use of a user-installed Output Summer connector. Using this connector, you can configure Output pairs I/O-2–I/O-3, I/O-4–I/O-5, I/O-6–I/O-7, and I/O-8–I/O-9 in redundant mode. See [Installing Output Summer Adapters](#), on [page 68](#), for more information on making redundant connections.

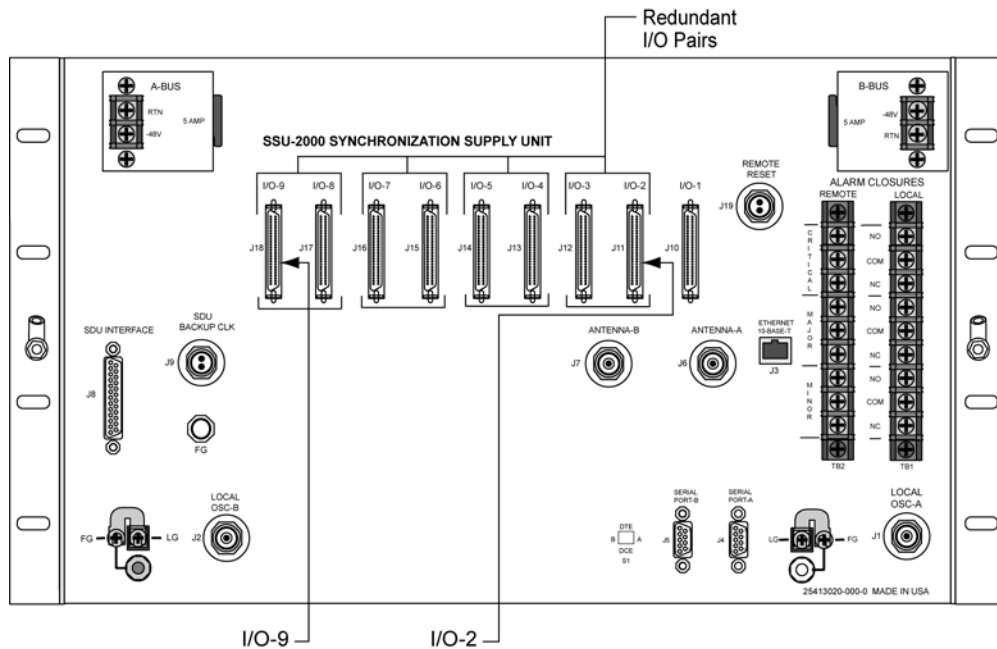

Figure 1-10. SSU-2000 Input/Output Connectors

Input and Output Adapter Panels

All Input and Output module signals connect to/from the rear panel of the main shelf (and expansion shelf) using 50-pin SCSI II type connectors.

To adapt signals from 50-pin SCSI connectors to conventional BNC (Balun) and 9-pin D-sub connections, you use Input and Output Adapter panels (I/O Adapter panels) that install in the rack either directly above or directly below the main or one of four possible expansion shelf.

All SSU-2000 connections are made on the rear of the Adapter panels; the connections to the telecommunications system are on the front of the Adapter panels.

The following adapter panels are available for use with the SSU-2000 Input and Output modules:

- Input I/O adapter for 3-port Input modules (DS1 or E1) – one adapter panel is required for each 3-port Input module used in the system.
- Input I/O adapter for 1-port Input modules (DS1 or E1) – one adapter panel serves up to four 1-port Input modules.
- Output I/O adapter for Output modules (75 ohm Balun Outputs) – one adapter panel accommodates one output module (non-redundant) or one pair of redundant modules.
- Output I/O adapter for Output modules (D9 outputs) – one adapter panel accommodates one Output module (non-redundant) or one pair of redundant modules.
- Output I/O adapter for Output modules (wire-wrap) – the 80-channel adapter panel accommodates four Output modules (non-redundant) or two pairs of Output modules. The 100-channel adapter panel accommodates five Output modules (non-redundant) or two pairs of redundant modules.

These adapter panels are shown in [Figure 1-11](#) and described in greater detail in [Chapter 7, Input Module Reference Data](#), and [Chapter 8, Output Module Reference Data](#).

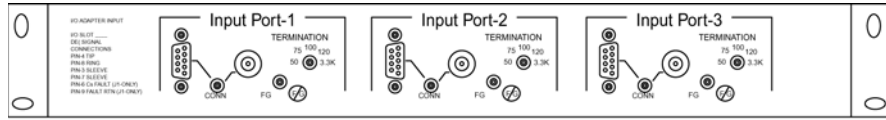

I/O Adapter for 3-Port Input Module

ss200018

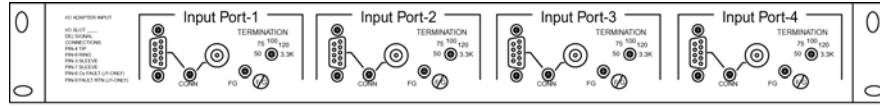

I/O Adapter for 1-Port Input Module

ss200019

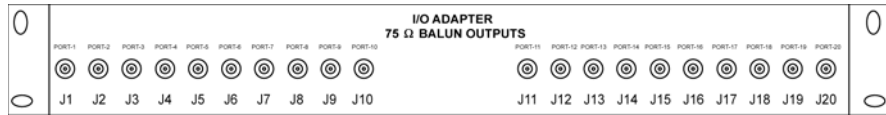

75 Ohm Balun I/O Adapter for Output Module

ss200020

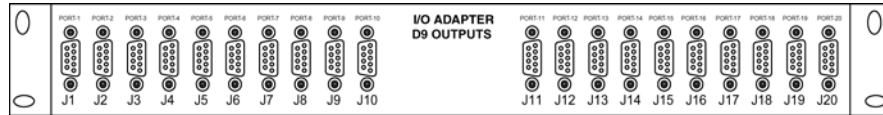

DE9 I/O Adapter for Output Module

ss200021

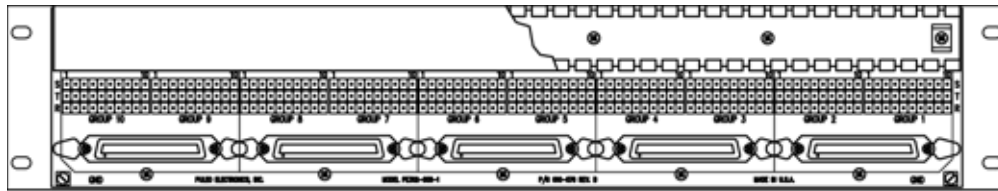

100-Channel High-Density Wire-Wrap I/O Adapter for Output Module

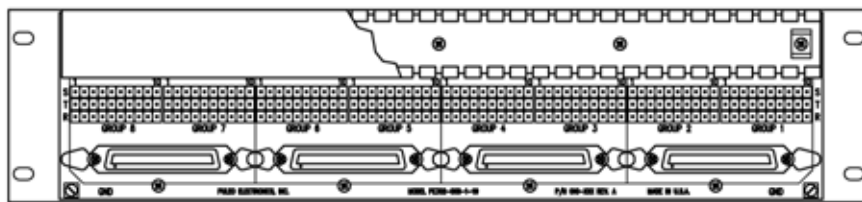

80-Channel High-Density Wire-Wrap I/O Adapter for Output Module

ss200090

Figure 1-11. I/O Adapter Panels for Input and Output Modules

Communications Protocol

This section summarizes the methods of controlling the SSU-2000 and the available software features, depending upon the system functionality required.

Software Interface

There are four methods of controlling the SSU-2000. The control interfaces available are:

TL1 – Transaction Language One

TL1 provides command sets to support all operation, administration, maintenance, and provisioning tasks required to maintain and control an SSU-2000 system. These tasks include configuring and provisioning security, monitoring system performance, configuring hardware, locating and handling faults, and performing equipment diagnosis and testing. Refer to the *SSU-2000 Technical Reference* for more information.

ICS – Interactive Command Set

ICS also provides command sets to support all operation, administration, maintenance, and provisioning tasks required to maintain and control an SSU-2000 system from a terminal connected to one of the SSU-2000 RS-232 serial ports. ICS commands are designed in a more readable interface for users with an instructional help facility. Refer to the *SSU-2000 Technical Reference* for more information.

NTP – Network Time Protocol

The Network Time Protocol (NTP) is used to synchronize the time of a computer client or server to another server or reference time source, such as a GPS receiver or local timing source.

The SSU-2000 implements the NTP v.3 (RFC 1305) version. It can run as a server application and a client application. In addition, a broadcast mode may be implemented as either a server or client. The NTP server always runs and the client and broadcast modes are enabled independently by assignment of addresses and setting of timers. Refer to the *SSU-2000 Technical Reference* for more information.

SNMP – Simple Network Management Protocol

The SSU-2000 offers two versions of SNMP: v2 and v3. SNMP v3 software offers additional security with authentication and privacy parameters. The security feature allows secure transactions to provide protection against modification of information, masquerade, and message stream modification.

Simple Network Management Protocol (SNMP) is based on a client-server query-response mode. A manager is the client generating the queries, while an agent is the server generating the responses.

The SSU-2000 SNMP is an SNMP agent that requires Ethernet connectivity. If SNMP is present, port 161 becomes the port of standard SNMP interactive communications, while port 162 becomes the trap port. Since the SSU-2000 SNMP supports all existing functions, full system control of the SSU-2000 is maintained through SNMP.

The SSU-2000 implements an SNMP agent. A Management Information Base (MIB) browser or the SNMP Manager is used to access, retrieve, and query information defined by the MIB.

All reports, queries, autonomous messages, control, provisioning, and administration (except for communication port parameters, Set User ID/Password, Set IP assignments, Reset connection, and SNMP community settings) are available through SNMP. Refer to the *SSU-2000 Technical Reference* for more information.

Software Versions

There are six different versions of software available for the SSU-2000, as indicated in [Table 1-2](#). The functionality and commands that are available vary from one version of software version to the next, depending on the specific features of the software package and are described in the *SSU-2000 Technical Reference*.

Table 1-2. Versions of Software for the Communications Module

Version	TL1	ICS	NTP	SNMP v2	SNMP v3
Basic System Load	X	X			
Basic w/NTP Support	X	X	X		
Basic w/SNMP v2 Support	X	X		X	
Basic w/SNMP v2 and NTP Support	X	X	X	X	
Basic w/SNMP v3 Support	X	X		X	X
Basic w/SNMP v3 and NTP Support	X	X	X	X	X

Basic System Load

The basic system load includes all TL1 and ICS support software. TL1 provides command sets to support all operation, administration, maintenance, and provisioning tasks required to maintain and control an SSU-2000e system. These tasks include configuring and provisioning security, monitoring system performance, configuring hardware, locating and handling faults, and performing equipment diagnosis and testing. Refer to the *SSU-2000e Technical Reference* for more information.

ICS also provides command sets to support all operation, administration, maintenance, and provisioning tasks required to maintain and control an SSU-2000e system from a terminal connected to one of the serial ports. ICS commands are designed in a more readable interface for users, and includes an instructional help facility. Refer to the *SSU-2000 Technical Reference* for more information.

Graphical User Interface

Symmetricon's SynCraft application is a software interface program that is available to provide local or remote monitoring and configuration functionality in a Microsoft Windows graphical user interface. Contact your Symmetricon sales representative for more information on the SynCraft Graphical User Interface, part number 14113245-000-0.

Overview of SSU-2000 Operation

After initial installation and configuration is completed, the SSU-2000 is capable of unattended operation. After power-up, where the external power supplies are turned on so that they supply power to the main shelf, the SSU-2000 performs a self-diagnostic test routine and properly initializes the hardware. Any active Alarms are time tagged and reported as Events. All Events are time tagged and the last 500 Events are stored in NVRAM. All Events can be remotely accessed and cleared by a user with the appropriate security level. Several optional levels of password protection are available for system protection as described in [Overview of the SSU-2000 Security System](#), on page 93.

After the internal oscillators on any installed Clock modules have warmed up, the SSU-2000 enters the ACQUIRE mode to phase lock the oscillators to the external references. After the SSU-2000 reaches the LOCKED mode on at least one of the Clock modules, any change of state is reported as an Event.

Synchronization Status Messages (SSMs)

The SSU-2000 supports input and output SSMs. SSMs provide a method for providing clock quality information to any equipment that uses synchronization inputs. [Table 1-3](#) describes the ANSI SSM values and the traceability associated with each value. [Table 1-4](#) describes the ITU SSM values and the traceability associated with each value.

Table 1-3. ANSI SSM Quality Level Definitions

Description	Quality Level	Abbreviation
Stratum 1 Traceable	1	PRS
Synchronized – traceability unknown	2	STU UNK
Stratum 2 traceable	3	ST2 TYPE II
Transit Node traceable	4	TNC TYPE I
Stratum 3E traceable	5	ST3E TYPE III
Stratum 3 traceable	6	ST3 TYPE IV
SONET Minimum Clock traceable (20 ppm clock)	7	SMC
Stratum 4 traceable	8	ST4
Do Not Use for synchronization	9	DUS

Table 1-4. ITU SSM Quality Level Definitions

Description	Quality Level	Abbreviation
Primary Reference Clock	2	PRC
Transit Node	4	SSUT
Local Node	8	SSUL
Synchronization Equipment Clock	11	SEC
Do Not Use for synchronization	15	DNU

The SSU-2000 handles SSMs in accordance with T1X1.3 TR33, T1.101-1999, GR-253, and 379-CORE.

Indicators and Controls

All modules installed in the SSU-2000 main shelf and the SDU-2000 expansion shelf contain status indicator lamps for displaying status. The LED indicators for each module are described in [Chapter 6, Clock Module Reference Data](#), [Chapter 7, Input Module Reference Data](#), and [Chapter 8, Output Module Reference Data](#). In addition, the Communications module collects status information from all installed modules, sets the alarm relays, and sends communications status alerting users of any Events that exceed alarm thresholds.

SDU-2000 Synchronization Distribution Unit

Up to four SDU-2000 Synchronization Distribution Units (expansion shelves) can be attached to the SSU-2000 for output expansion ([Figure 1-12](#) and [Figure 1-13](#)). Each expansion shelf contains two Buffer modules and 14 output modules (can be a combination of output modules). Four expansion shelves can hold up to 56 Output modules capable of generating an additional 1120 synchronized clock outputs for system distribution. Each expansion shelf is connected to the main shelf with redundant clock cables to protect against cable faults.



Figure 1-12. Front View of the SDU-2000 Expansion Shelf

The SDU-2000 Expansion shelf is designed to be compatible with international environmental, safety and electromagnetic compliance (EMC) standards for –48/60 VDC powered telecommunication transmission equipment installed in telecommunication centers with inside telecom signal connections. The farthest Expansion shelf may be located up to 200 feet (61 meters) from the SSU-2000 main shelf.

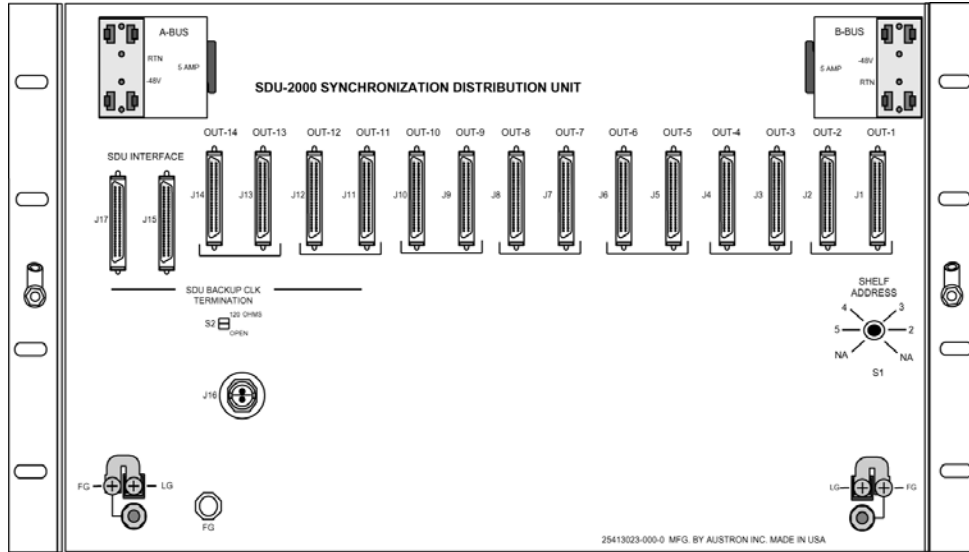

ss200027

Figure 1-13. Rear View of the SDU-2000 Expansion Shelf

Functional Overview

Figure 1-14 shows a simplified functional block diagram of the SDU-2000 Expansion shelf. The SDU-2000 interfaces with the SSU-2000 main shelf in two-way communications through the SSU/SDU interface cables and receives synchronization clocks that are buffered and used to produce the differential output signals at the connector panel, as shown in Figure 1-14. A second interface cable supplies the SDU-2000 Expansion shelf with a backup clock (D Clock) which can sustain the expansion shelf even if the main cable is accidentally disconnected. An address switch on the connector panel of the expansion shelf identifies each additional shelf to the main shelf for status and firmware downloading purposes.

Each expansion shelf extends the expansion bus and D clock to the next shelf in the daisy chain. The last expansion shelf uses a set of termination plugs on the Expansion Bus Connector and the Backup-Clock Connector.

Each expansion shelf can support any combination of up to ten 2048 kHz, Composite Clock (CC), or framed 2048 kbit/s (E1) or DS1 modules, each capable of generating 20 output signals for distribution to large networks. Each Output module generates a phase-locked signal of 1.544 Mbps (DS1) or 2048 kbit/s (E1) using one of three 4 KHz clocks supplied by the clock oscillators in the SSU-2000 main shelf. The phase locked clock signal is buffered and summed with a companion Output module in redundant pairs to generate a set of 20 independent output clock signals for distribution to large networks.

Output modules are available to support the following formats:

- 2048 Kbit/s (E1)
- DS1, SF (D4) and ESF
- 2048 kHz
- Composite Clock (64/8 kHz)
- RS-422
- Japanese Composite Clock
- Japanese Sine Wave
- DS1/E1 Line Re-Timing

Expansion Shelf Features

The SDU-2000 expansion shelf consists of the following major components.

- Expansion shelf
- One or two Buffer modules; where two provide a more robust system
- Up to 14 Output modules, which can be a combination of Output module types
- Connector panel with five groups of output connectors, SDU interface connector group, dual power connectors, dual frame ground connectors, and a shelf address switch.

Clock Source

The clock inputs for the first SDU-2000 expansion shelf in an SSU-2000 system are supplied by the A and B Clock modules in the main shelf. A multi-pin connector on the rear panel of the SSU-2000 (labeled J8 SDU Interface) provides the reference signals from the main shelf Clock modules for use by the SDU-2000 expansion shelves. The clock source is usually connected to J15.

SDU Backup Clock

For redundancy, a backup clock is supplied to each expansion shelf to allow it to continue operating if the main expansion bus (cable) is accidentally disconnected or dislodged. The SSU-2000 provides a backup clock (Clock D) to the SDU Backup Clock terminal, labeled J16. Using a Tee-connector, Connector J16 feeds an additional SDU-2000 shelf.

When installing an expansion shelf, move the clock terminator from J9 on the SSU-2000 or connector J16 from a previous SDU-2000 expansion shelf, and install the terminator on J16 of the last expansion shelf in the daisy chain.

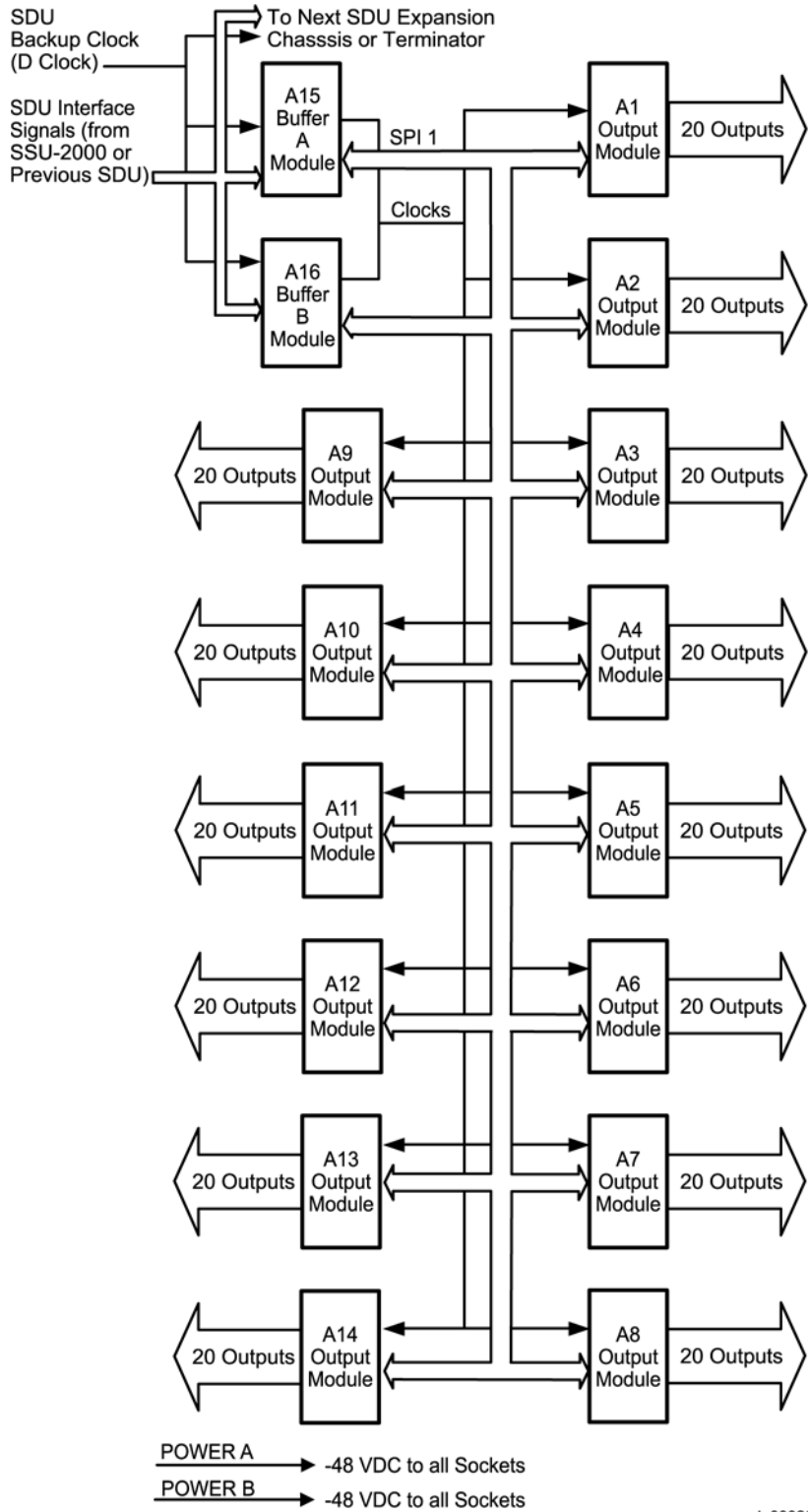

Figure 1-14. SDU-2000 Block Diagram

Setting the Expansion Shelf Address

Each SDU-2000 Expansion shelf must be correctly configured for its position in the daisy chain. The main shelf's address is 1. The SDU shelf address selector is numbered from two to five. Set the first expansion shelf address to 2. Set the address on additional shelves sequentially, as shown in [Table 1-5](#).

Table 1-5. Expansion Shelf Addresses

Shelf	Address
Main Shelf	1
Expansion Shelf 1	2
Expansion Shelf 2	3
Expansion Shelf 3	4
Expansion Shelf 4	5

Buffered Clocks

The signals that are provided by the main shelf Clock modules to the Buffer modules in the expansion shelf are isolated versions of the signals used by the Output modules in the main shelf. This prevents the expansion shelf and its cabling from affecting the outputs of the main shelf.

SDU Module Features

The SDU-2000 expansion shelf supports all Output modules available for the main shelf, and Buffer modules. The SDU-2000 expansion shelf can support up to 14 Output modules.

- One or two Buffer modules, assigned to slots A15 and A16
- One to 14 Output modules; a mixture of Output module types, where each group of two modules must be identical

The last two module slots in the expansion shelf, labeled A15 and A16, contain the Buffer modules that buffer the corresponding Clock and Communications modules in the main shelf. The buffered signals from these modules are distributed through the motherboard to the Output modules.

Other common module features include:

- Any module can be inserted or removed while power is applied without affecting the operation of other modules in the system
- All modules are individually fused to protect the system in case of a short circuit on any one module
- The SSU-2000 and the SDU-2000 share common Output modules
- All modules have front panel LED status indicators
- All modules are equipped with ejector tabs for ease of installation and removal
- All modules are secured in place with captive screws to provide module security and reduce the occurrence of unauthorized removal
- All modules, except the Buffer module, have an integrated CPU with firmware and are software configurable through the SSU-2000. See [Configuring a Conventional SSU/TSG System](#), on page 266, for additional information
- Each module slot has two associated hybrid DIN connectors on the chassis backplane. The hybrid contacts of these connectors are used for Power, Logic Ground, and Frame Ground connections
- Each module slot has three pins on each hybrid DIN connector that allows the system to detect module removal and insertion. This capability provides plug-and-play capability.

Connector Panel Features

The expansion shelf provides connections for external power, grounding, clock inputs, and output connections. All modules plug in from the front of the shelf.

Controls and Indicators

All modules installed in the SDU-2000 expansion shelf contain LED status indicators for displaying status. Any faults from the installed modules are sent to the SSU-2000 Communications module through the buffer modules; the appropriate alarm relays are set and communication status is sent to alert users of any events that exceed specified alarm thresholds.

Chapter 2 Installing the SSU-2000

This chapter provides guidelines and procedures for installing and powering up the SSU-2000 Synchronization Supply Unit.

In This Chapter

- Unpacking and Inspecting the Shelf
- Preliminary Procedures
- Rack Mounting the SSU-2000
- Making Ground and Power Connections
- Making Signal Connections
- Making Alarm Connections
- Connecting Antennas
- Connecting an SDU-2000 Expansion Shelf
- Handling Modules
- Installation Checklist
- Powering Up the SSU-2000
- Normal System Indications During Turn-Up
- After Turn Up

Unpacking and Inspecting the Shelf

The SSU-2000 is packaged to protect it from normal shock, vibration and handling damage. Care should be taken during unpacking and installation to avoid damaging the unprotected unit.



Caution: To avoid damage, use proper static control precautions when handling modules! Protect the equipment against ESD (Electrostatic Discharge) by using a grounded protective wrist strap and normal equipment grounding.

1. Unpack all equipment carefully and check it against the purchase order.
2. Inspect the equipment for shipping damage, including bent or loose hardware, broken connectors, or other visible defects. Notify Symmetricom and the carrier who delivered the equipment if you suspect that it was damaged in transit.

If any items are missing, contact Symmetricom Global Services.



Recommendation: Keep all packaging materials in the event the shelf or components must be returned or shipped to another location.

Preliminary Procedures

Make sure that the following preparations are in place before installation.

- Ensure that standard installation tools and materials are available, see [Installation Tools and Materials](#), on page 61.
- The installation site is secured:
 - Access to the location can only be gained by service personnel or users who have been instructed about the reasons for the restrictions applied to the location and about any precautions that shall be taken; and
 - Access is through use of a tool or lock and key, or other means of security, and is controlled by the authority responsible for the location
- Ensure that the system location does not cause electromagnetic interference with other equipment in the area, see [Electromagnetic Interference \(EMI\) Considerations](#), on page 61.
- Ensure that adequate ventilation space is available in the rack or equipment cabinet to safely operate the shelf, see [Ventilation Considerations](#), on page 62.
- The SSU-2000 is suitable for installation over concrete or other non-combustible surfaces only.

- Ensure that the mounting rack or equipment cabinet is properly grounded and has power available, see [Making Ground Connections](#), on page 65.



Warning: Before beginning the SSU-2000 installation, be sure to remove the A-BUS and B-BUS fuses on the rear panel of the shelf. The unit is not equipped with a power on/off switch and both fuses must be removed to ensure the shelf is not accidentally powered up.



Caution: To avoid electrostatic discharge (ESD) damage to equipment, follow the ESD precautions as listed in this guide.



Recommendation: Symmetricom recommends that you follow all applicable local building electrical codes when installing the SSU-2000.

Installation Tools and Materials

The following required standard tools and materials (not supplied) are required for installing the SSU-2000:

- Standard tool kit
- Cable ties or acceptable cable clamps
- 16 AWG (minimum) wire for –48V, RTN, and frame ground
- 18 AWG wire for connecting office alarms
- 22 AWG shielded twisted pair wire-wrap cable (Amp #640433-7 or equivalent)
- Wire-wrap tool
- No. 10 screws, flat washers, and locking washers for mounting the equipment rack
- Digital Voltmeter
- Straight-through RS-232 cable
- Laptop or PC with a terminal emulation program such as HyperTerminal or ProComm Plus

Electromagnetic Interference (EMI) Considerations

Electromagnetic interference (EMI) from one instrument can adversely affect the operation of nearby equipment. To prevent the SSU-2000 from interfering with other equipment, it must be installed and operated as described in the following paragraphs.

All cables connected to the SSU-2000 should be shielded with metal connector shells. The connectors on the rear panel of the shelf are shielded, with the shields connected to frame ground. Follow local procedures for shield grounding. The screws on all cables must be securely fastened to their corresponding connectors on the rear of the unit. While the unit is in operation, there must be a module or blank panel installed in every slot. Also, the captive screws, located at the top and bottom of the module panel, must be properly secured.



Caution: To maintain EMC compliance, use only properly shielded cabling on all telecom signal wiring, including I/O, clocks, and Ethernet connections. Ensure that connections are appropriately grounded.

Ventilation Considerations

For proper ventilation, there should be at least 2 RU (3 inches, 7.6 cm) of free space above and below the shelf.



Caution: To avoid excessive heat build-up resulting in equipment damage, provide proper ventilation and cooling of the equipment.

Rack Mounting the SSU-2000

The SSU-2000 shelf, when installed, occupies 10.5 in (26.7 cm) of vertical rack space, has a depth of 12 in (30.5 cm), and a width of 19 in (48.3 cm). When installing more than one SSU-2000, each unit must have at least one inch (2.5 cm) of clearance above and below to ensure proper cooling. There should be at least three inches (7.6 cm) of free space below the bottom shelf. It is recommended that at least one I/O adapter panel be inserted between each unit.



Caution: Failure to provide proper ventilation can result in excessive heat build-up resulting in equipment damage. Symmetricom suggests that you insert an I/O adapter panel between shelves. See [Figure 2-1](#).

SSU-2000 Shelf

The shelves mount flush to the rack or at distances of either 2 inches (5.1 cm) or 5 inches (12.7 cm) from the front of the rack. An SSU-2000 rack mounting diagram is shown in [Figure 2-1](#).

1. Attach a mounting bracket to each side of the shelf by aligning two columns (three holes per column) of the bracket with the holes on the side of the shelf.

Use suitable screws for attaching the mounting bracket. Ensure that both brackets are attached at equal distances from the front of the shelf.

2. Mount the instrument to the front of the rack rails with the appropriate number of screws and washers for the rack.

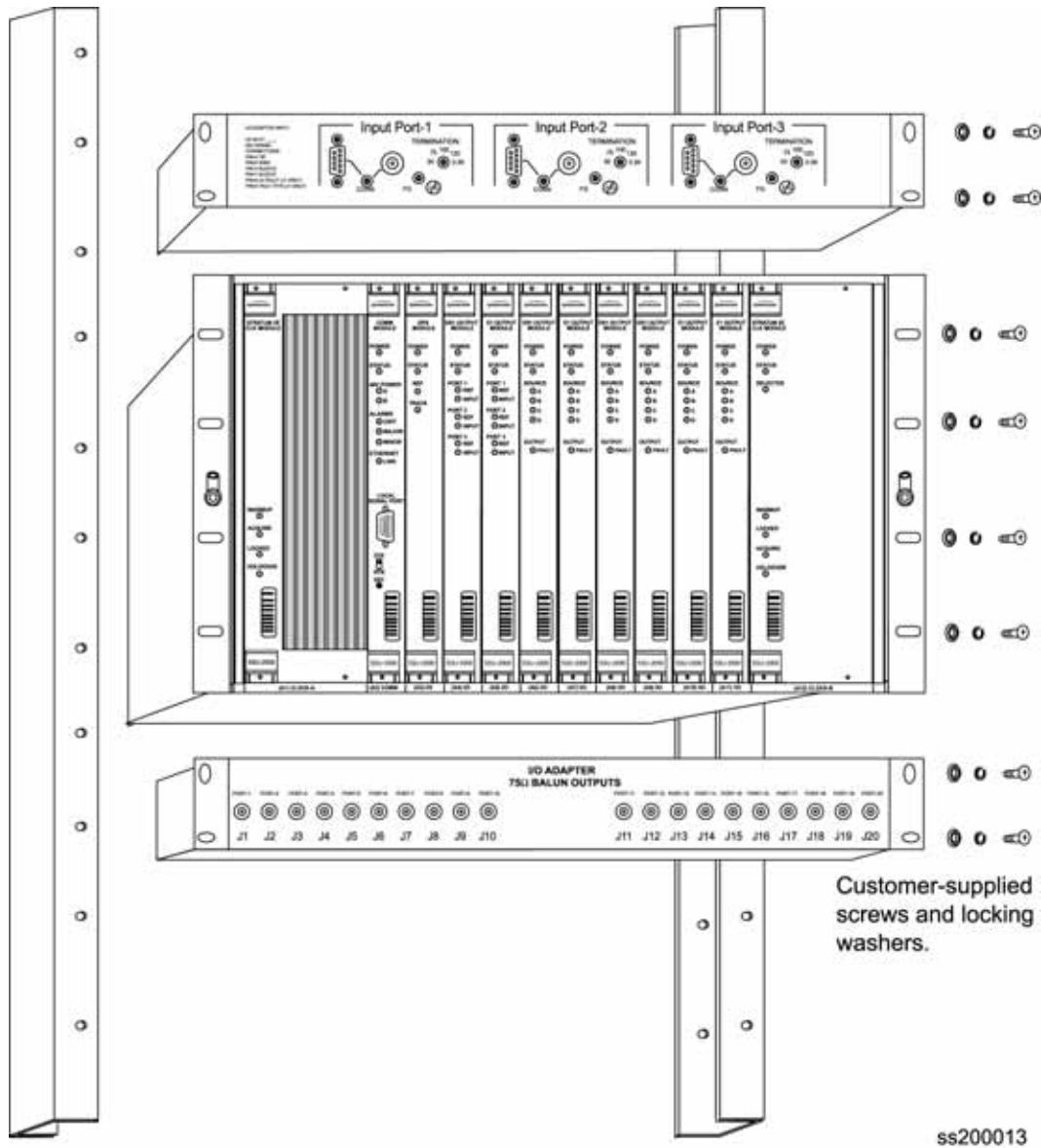

Figure 2-1. Shelf and I/O Adapter Rack Mounting

3. If you are not using Expansion shelves, verify that the Bus Termination Assembly is inserted into J9 on the rear panel of the main shelf.



Recommendation: When possible, install the shelf at eye level to aid in viewing and connecting cables.

I/O Adapter Panels

The procedure for attaching the four types of I/O adapter panels to the rack are identical. The location of the I/O adapter panels is limited only by the length of the interconnecting cable. Input adapter cables are restricted to one meter. Output adapter cables are available in lengths from one to two meters in increments of 0.1 meter; see [Chapter 9, Hardware Configuration Guide](#), for part numbers.

1. The I/O adapter panels may be mounted flush to the top or bottom of the shelf. Use suitable screws for attaching the I/O adapter panel. Ensure that both brackets are attached at equal distances from the front of the unit.
2. Mount the panels to the front of the rack rails with four screws and washers.



Recommendation: Although I/O adapters may be located as necessary, Symmetricom recommends that you mount the Input I/O adapter panels above the shelf to accommodate the shorter cable length; mount the Output I/O adapter panels below the shelf.

Making Ground and Power Connections

The SSU-2000 shelf has redundant -48VDC power input connections labeled A-BUS and B-BUS. The A-BUS connection is a 2-position #6 terminal block in the upper left corner of the rear panel, and the B-BUS connection is a 2-position #6 terminal block in the upper right corner of the rear panel. The terminal positions are labeled -48V and RTN. The -48V side of each bus is fused with a 5 Amp fuse. The -48V power inputs are DC Isolated from frame ground and logic ground. Both the A-BUS and B-BUS are fed to the individual module slots via the backplane. Refer to [Figure 2-4](#) for a view of the SSU-2000 rear panel.



Caution: For continued fire protection, replace fuse with specified type and rating. Fuse: GMT-5 (5A @ 60vDC).
This unit must be grounded.
Refer all servicing to qualified personnel.



Caution: To avoid equipment damage, ensure that the power terminal covers are installed after connecting the -48V power.



Caution: To provide proper I/O connector grounding, ensure that when removing or installing Summer Output connectors that all screws are tightened securely.

Making Ground Connections

After the SSU-2000 is installed in a suitable rack, connect the shelf to a proper earth ground.

1. Run a cable from the frame ground (FG) lug to earth ground.

Keep this cable as short as possible. Frame ground connections are made using two #8-32 studs labeled FG on each side of the lower rear panel. There are also provisions for making logic ground connections when required by a specific customer's installation. These connections are labeled LG and are located next to the FG studs and are strapped together with a jumper, as shown in [Figure 2-2](#). The jumper strap can be removed to isolate the frame and logic grounds. Logic ground is AC bypassed to frame ground by capacitor C1 on the backplane.



Note: To isolate frame ground from logic ground, remove the two jumpers connecting Frame Ground to Logic Ground. Once the connections to LG have been opened, secure the jumpers to the rear panel by tightening the FG screws. If desired, either of the LG terminals may be used to connect a separate Logic Ground cable.

2. Using a digital voltmeter, measure between the ground and chassis and verify that no voltage exists between them.

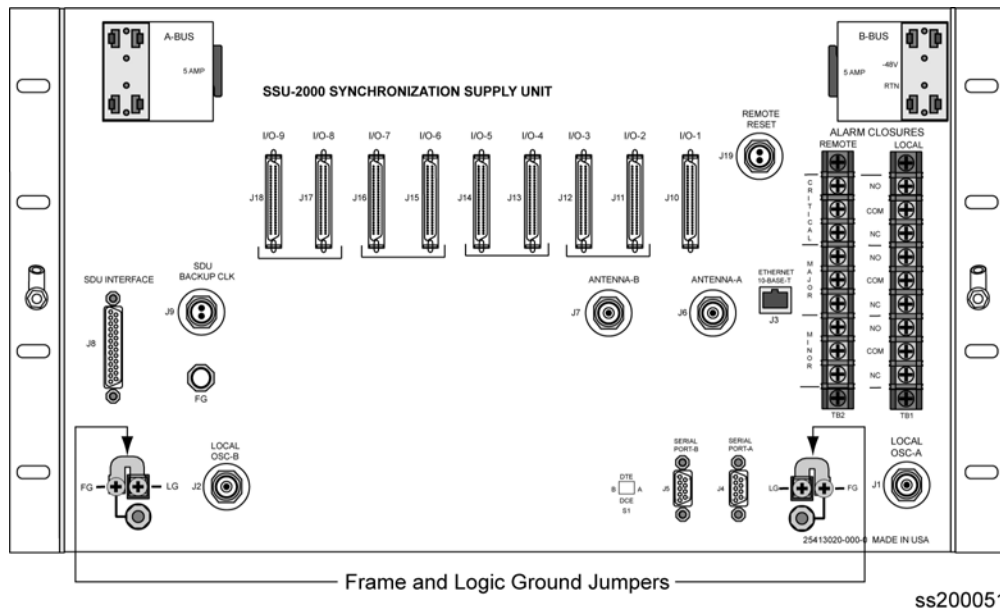

Figure 2-2. Frame and Logic Ground Jumpers

Connecting Power

1. Locate the power terminal blocks on the rear panel, as shown in [Figure 2-3](#).
2. Remove both 5 A fuses. You will replace them at the end of the installation procedure.
3. Using 16 AWG (minimum) stranded wire, connect primary power to the A-BUS screws and the secondary power to the B-BUS screws. Symmetricom recommends that you use a #6 spade lug termination for each power lead.

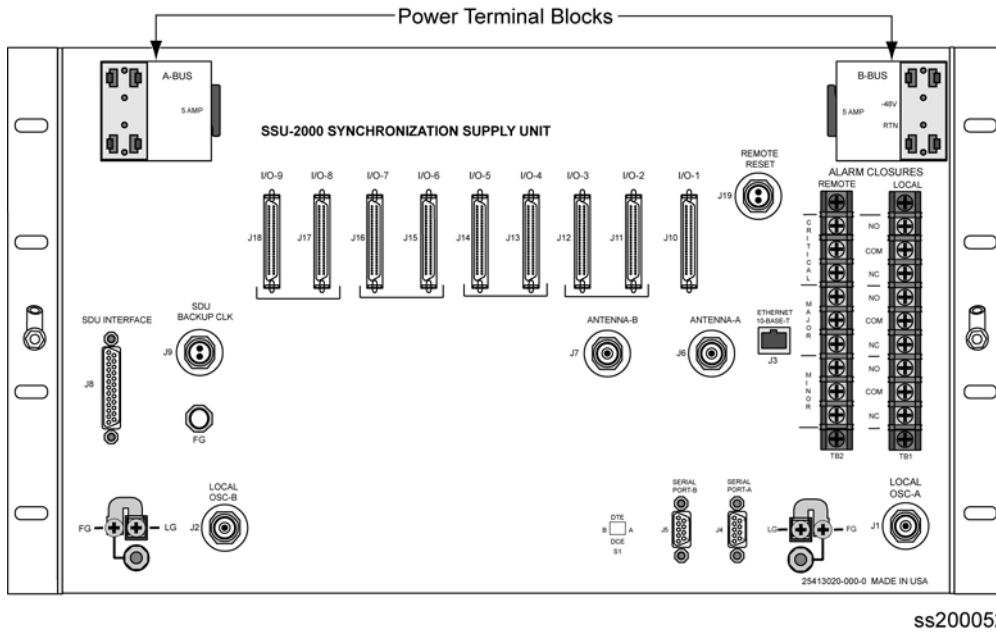

Figure 2-3. Power Terminal Blocks

Making Signal Connections

Making I/O Connections

The SSU-2000 shelf has I/O interface connections for connecting the SSU-2000 to the corresponding I/O adapter panels. Refer to [Chapter 7, Input Module Reference Data](#), and [Chapter 8, Output Module Reference Data](#), for information regarding the different type I/O adapter panels available and the associated cables used to connect the SSU-2000 to the I/O adapter panels. [Figure 2-4](#) shows the rear panel of the SSU-2000.

All I/O connections are made through the nine 50-Pin Micro-D female connectors, J10 through J18. Each connector is associated with a specific chassis slot. [Table 2-1](#) lists the relationship between the I/O slot and the rear panel connector. Connectors J10 through J18 are labeled I/O-1 through I/O-9. The signal connections on these I/O connectors are set up in differential pairs as Tip and Ring connections.

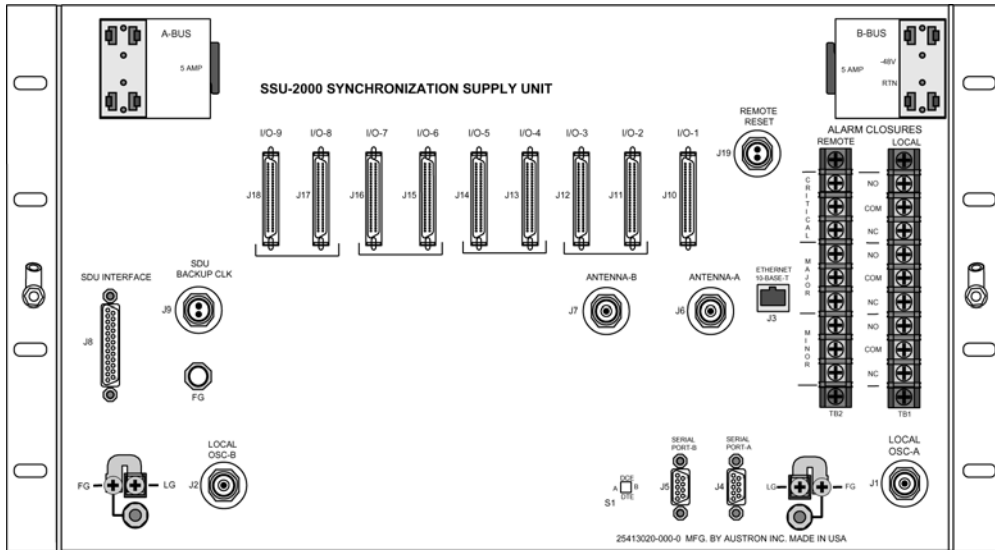

ss200014

Figure 2-4. SSU-2000 Rear Panel

Table 2-1. I/O Module Slot to I/O Connector Relationship

Label (Name)	Chassis Slot	I/O Connector
I/O-1	A3	J10
I/O-2	A4	J11
I/O-3	A5	J12
I/O-4	A6	J13
I/O-5	A7	J14
I/O-6	A8	J15
I/O-7	A9	J16
I/O-8	A10	J17
I/O-9	A11	J18

Installing Output Summer Adapters

To create an A/B pair of Output modules in a redundancy configuration, you need to install Output Summer adapters (part number 22013070-000-0) on the corresponding outputs as shown in [Figure 2-5](#). All Module A outputs are summed with the corresponding outputs of Module B, providing 1:1 output protection (1:1 redundancy). Output pairs in slots A4/A5, A6/A7, A8/A9, and A10/A11 are available for configuration in redundant mode using Output Summer connectors. The pinout of the Output Summer adapter is the same as the I/O interface connectors (see Chapter 7 of the *SSU-2000 Technical Reference*).

You can install the Output Summer adapters before you place the SSU-2000 in-service or after it begins to generate outputs.

Installing Output Summer Adapters on an Out-of-Service SSU-2000

To install the Output Summer adapter on an out-of-service SSU-2000:

1. Remove the two retaining screws on each connector that the Output Summer adapter is to be installed on.



Caution: To avoid possible electrostatic discharge problems after *removing* an Output Summer adapter, you must replace the screws securing the I/O connectors on the rear panel of the SSU-2000.

2. Install Output Summer adapters on all I/O connector pairs that require redundancy, see [Figure 2-5](#).
3. Tighten all Output Summer adapters screws securely.
4. Connect 50-pin Micro-D output cables between the I/O Adapter panel and the Output Summer adapter as required.

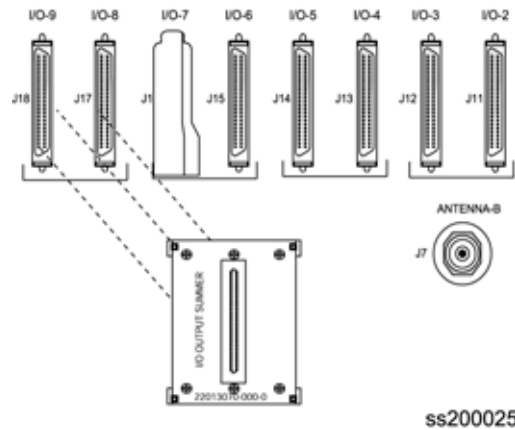

Figure 2-5. Installing the Output Summer Adapter

Installing Output Summer Adapters on an In-Service SSU-2000

If you choose to install Output Summer adapters on an SSU-2000 that is generating outputs, you may experience a LOS alarm and possibly a “Module Removed” alarm. The alarms may occur under the following conditions:

- A LOS alarm will occur if you remove the output cable from the rear panel of the SSU-2000 and that cable carries timing signals from the associated Output module
- A “Module Removed” alarm will occur if you remove an Output module from the SSU-2000 shelf in order to place it in a slot appropriate for output summing.
- Alarm conditions downstream from the SSU-2000 and in the SSU-2000 may result when you attach the Output Summer and the protection scheme is not identical (1 + 1 or 1-for-1) in both Output modules.
- Alarm conditions downstream from the SSU-2000 and in the SSU-2000 may result due to misalignment of framing bits when you attach the Output Summer.

The alarm conditions remain until the SSU-2000 returns to normal operating conditions.

1. Remove the interconnect cables from the selected module pair. A LOS alarm occurs for the affected output(s).
2. Remove the two retaining screws on each connector that the Output Summer adapter is to be installed on.
3. Install the Output Summer Adapter and hand tighten the retaining screws.
4. Provision the affected Output modules using SynCraft or ICS or TL1 commands:

Set the desired options on the Output modules.

Restart the affected Output modules (RESTART xAy).

Save the new user configuration (SET-SAVE xAy).

5. Install the appropriate interconnect cable to the Output Summer Adapter.
6. Dress the cables as appropriate.

You can install the Output Summer Adapters without the risk of alarms in the following situations:

- You install the Output Summer Adapter to an SSU-2000 that has two in-service Output modules in the desired paired slot location.
- You install the Output Summer Adapter to an SSU-2000 that has one in-service Output module in one of the desired paired slot locations and you then install the second Output module in the other slot location.

To install the Output Summer adapter on an in-service SSU-2000:

1. Remove the interconnect cables from the selected module pair. A LOS alarm occurs for the affected output(s).
2. Remove the two retaining screws on each connector that the Output Summer adapter is to be installed on.
3. Install the Output Summer Adapter and hand tighten the retaining screws.
4. Install the second Output module in the appropriate slot and tighten the retaining screws.
5. Provision the affected Output modules using SynCraft or ICS or TL1 commands:

Set the desired options on the Output modules.

Restart the affected Output modules (RESTART xAy).

Save the new user configuration (SET-SAVE xAy).

6. Install the appropriate interconnect cable to the Output Summer Adapter.
7. Dress the cables as appropriate.

Making Communication Connections

The rear panel of the SSU-2000 shelf has connections for three communications interfaces, two EIA-232 Serial Port connections, and one Ethernet connection. These ports allow communication between the SSU-2000 and a terminal or PC. Each port is configured independently.



Note: A third EIA-232 serial port may be connected to the Communications module. Refer to [Communications Module](#), on page 150, for more information.

Refer to [Table 2-2](#) for the serial and Ethernet communications port assignments.

Table 2-2. Communications Port Assignments

Port #	Function	Protocol
Serial Ports (EIA-232)		
A (J4)	User-selectable as either an ICS or a TL1 interface. The port defaults to ICS upon initialization	ICS (Default), TL1
B (J5)	User-selectable as either an ICS or a TL1 interface. The port defaults to ICS upon initialization	ICS (Default), TL1

Table 2-2. Communications Port Assignments

Port #	Function	Protocol
Local (Comms Module)	User-selectable as either an ICS or a TL1 interface. The port defaults to ICS upon initialization	ICS (Default), TL1
Ethernet Ports (Telnet)		
23	User-selectable as either an ICS or a TL1 interface. The port defaults to ICS upon initialization	ICS (Default), TL1
123	This port is designated for NTP only	NTP
161	This port is designated for SNMP Interactive	SNMP Interactive
162	This port is designated for SNMP Trap transmission	SNMP Trap
2000	This port is designated for TL1 only	TL1

EIA232 Serial Port Connections

Both RS-232 serial port connections are made through filtered DE9S female connectors on the rear panel. These ports allow connection to a terminal or PC for remote monitoring and control. One is on connector J4 and is labeled Serial Port A, the other is on connector J5 and is labeled Serial Port B. When connecting to these ports, use a shielded direct-connect cable with the shield connected to pin 1.

Serial Port DTE/DCE Switch

The serial port DTE/DCE switch is located on the lower right side of the rear panel, as shown in [Figure 2-6](#). Each port (A and B) may be configured as either DCE (default, connection to PC) or DTE (connection to modem). The right switch controls port A and the left switch controls port B.

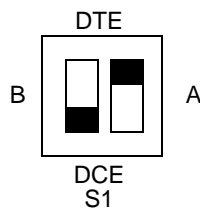
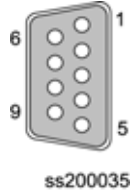

Figure 2-6. DTE/DCE Slide Switch

The default EIA-232 settings for both serial ports are 9600 baud, no parity, 8 data bits, 1 stop bit, echo on, ASCII mode, and handshaking disabled. To change these settings, connect the SSU-2000 to a terminal device or PC using a serial communications program protocol. See [Communicating by Serial Port](#), on page 91, for more information.

[Table 2-3](#) shows the EIA-232 Connector pin assignments for the SSU-2000 DE9 communications connectors.

Table 2-3. EIA-232 Connector Pin Assignments

Signal	Pin	Pin	Signal	Connector Orientation DE9S
FG	Shield	5	Logic Return	
	9	4	DSR	
CTS	8	3	TXD	
RTS	7	2	RXD	
DTR	6	1	DCD	

Making Ethernet Connections

The Ethernet 10-Base-T connection is located on the rear panel connector J3, which is a shielded RJ45 receptacle labeled Ethernet 10-Base-T. See [Communicating by Ethernet](#), on page 92, for more information on connecting and using the Ethernet port.

Local Oscillator Outputs

The SSU-2000 has two Local Oscillator (LO) connections J1 and J2 on the rear panel. The signals on these connectors are disabled, and the connectors are capped to minimize radiated emissions. Removing these caps causes the SSU-2000 shelf to exceed EMC specifications.

Remote Reset

The SSU-2000 shelf has a remote reset input which can be used to remotely initiate a system reset if you cannot communicate with the shelf using the serial or Ethernet ports. The remote reset connections are made via connector J19, which is a BNO connector labeled REMOTE RESET. A contact closure across the pins for three to five seconds resets the Communications module; pressing the Reset button on the Communications module performs the same function (see [Resetting the Module](#), on page 155).

Making Alarm Connections

The SSU-2000 has two alarm terminal blocks located on the rear panel for attaching external circuits to the SSU-2000, and are shown in [Figure 2-7](#). Both blocks are nine-position, #6 filtered terminal blocks. The local connections are made on TB1 and the remote connections are made on TB2. The terminal blocks are labeled Alarm Closures, Local and Remote. The connections are labeled NO (normally open), COM (common or wiper) and NC (normally closed) for each of the alarm categories CRITICAL, MAJOR and MINOR.

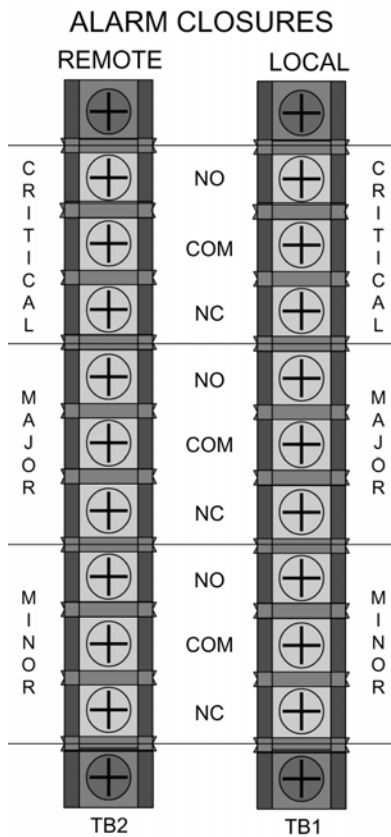

ss200015

Figure 2-7. Alarm Terminal Blocks

Alarm Relays

The Communications module contains six Form C relays used for alarm reporting. The relays provide contact closures for Local Critical, Local Major, Local Minor, Remote Critical, Remote Major, and Remote Minor alarm conditions. Switching capacity is up to 1 ampere, with a voltage up to 72 VDC. When the module is installed, all relays are in the “no alarm” condition (corresponding ALARMS LEDs are off). Each Remote/Local relay pair is controlled by the same control bit in the LCA that controls the LEDs. [Table 2-4](#) shows the default state of each relay pair (energized/de-energized), the “no alarm”, and “alarm” connections.

Table 2-4. Alarm Relay Connections

REM/LOC Pair	Condition (default shown first)	Connection: TB1/TB2
CRITICAL	Energized: no alarm De-energized: alarm	COM – NC COM – NO
MAJOR	De-energized: no alarm Energized: alarm	COM – NC COM – NO
MINOR	De-energized: no alarm Energized: alarm	COM – NC COM – NO

Perform the following steps to ensure proper alarm connections to the SSU-2000.

1. Remove both fuses from the rear panel.
2. Locate the ALARM terminal blocks connectors labeled MAJOR ALARMS (TB1) and MINOR ALARMS (TB2) on the rear panel.
3. Connect office alarms to the REMOTE and LOCAL terminals with 18 AWG wire.
4. Verify that correct wiring connections have been made.
5. Reinstall both fuses.



Caution: For continued fire protection, replace fuse with specified type and rating. Fuse: GMT-5 (5A @ 60vDC).
This unit must be grounded.
Refer all servicing to qualified personnel.



Note: In an alarm condition or loss of DC power, the contact between the NO and COM closes and the contact between the NC and COM opens.

Connecting Antennas

The SSU-2000 shelf has two antenna connections on the rear panel. The antenna connections are made via isolated TNC connector J6 labeled ANTENNA-A and Isolated TNC connector J7 labeled ANTENNA-B. These TNCs are DC isolated and AC bypassed to frame ground. These connections are used for radio receiver antenna connections only. Refer to the *SSU-2000 Technical Reference* for installation procedures and additional instructions.



Warning: To avoid serious personal injury or death, exercise caution when working near high voltage lines. In particular:

- Use extreme caution when installing the GPS antenna near, under, or around high voltage lines.
- Follow local building electrical codes for grounding using the frame ground lugs integrated with the SSU-2000 shelf.

Connector J6 is wired to slot A3 in the shelf, and Connector J7 is wired to slot A5.

Connecting an SDU-2000 Expansion Shelf

The SSU-2000 Main shelf has two interface connectors to connect an SDU-2000 Expansion shelf. You can connect up to four SDU-2000 shelves in a daisy-chain fashion using the Expansion Interface cable (part number 12013050-xxx-0 and the Backup Clock cable (12013115-xxx-0). These connections are made through connector J8, a DB25S female connector with locking post, labeled SDU INTERFACE, and connector J9, a BNO connector labeled SDU BACKUP CLK. These connectors are on the rear panel of the SSU-2000, and are shown in [Figure 2-8](#). The corresponding connectors on the rear panel of the SDU-2000 are shown in [Figure 2-9](#).

All signals on J8 are in differential pairs; each pair is terminated by installing the Expansion Terminator (part number 12013049-000-0), which has a series 0.001 μ F capacitor and 120 Ω resistor. The SDU backup clock signal on connector J9 is a differential pair; it is terminated with 120 Ω using switch S2 on the rear panel.



Caution: To avoid damage to the J9 connector or the BNO tee connector, be sure to align its internal pins with the mating connector. The tee connector *does not* rotate once it is installed. If J9 is damaged, you will have to replace the entire shelf.

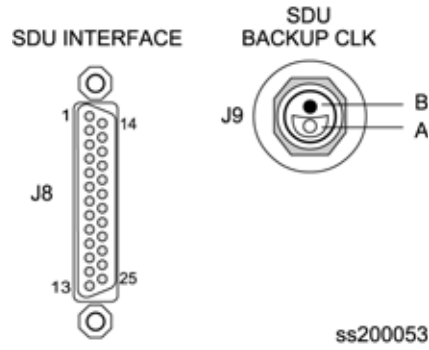

Figure 2-8. SDU Interface (J8) and Backup Clock (J9) Connectors

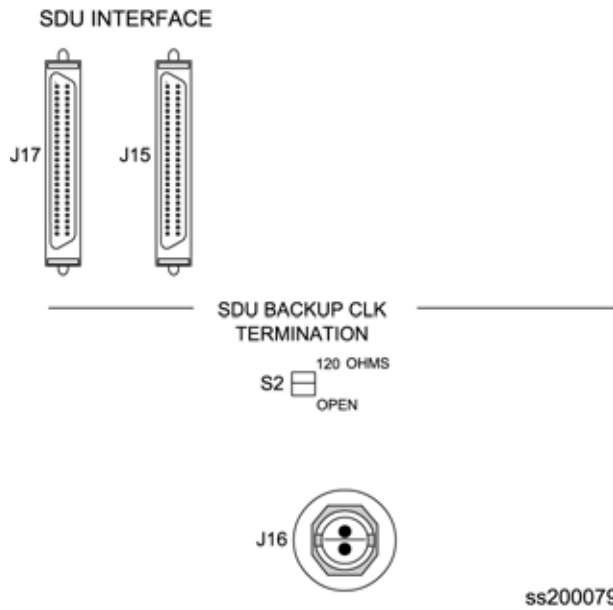

Figure 2-9. SDU Interface (J17 and J15) and Backup Clock (J16) Connectors

If you are not installing an SDU-2000 Expansion shelf, you *must* install the Expansion Terminator on J8 on the rear panel. [Figure 2-10](#) shows the SSU-2000 Expansion Terminator.

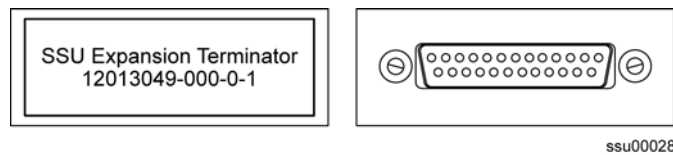

Figure 2-10. SSU Interface (J8) Expansion Terminator

Install the SDU-2000 Expansion shelf using the procedure described in [Rack Mounting the SSU-2000](#), on page 62. Then install power and ground connections using the procedure described in [Making Ground and Power Connections](#), on page 64.

Connecting a Single SDU-2000 Expansion Shelf

To connect a single SDU-2000 to the SSU-2000 main shelf, use the following procedure. [Figure 2-11](#) shows the wiring diagram for a single SDU-2000 installation.

1. Remove the Expansion Terminator (part number 12013040-000-0-1, if installed) from J8 on the rear panel of the SSU-2000. Set the terminator aside for use in step 3, below.
2. Attach one end of the Expansion Cable (part number 12013050-xxx-0; the xxx indicates the length of the cable) to J8 on the rear panel of the SSU-2000.
3. Attach the other end of the Expansion Cable to either J17 or J15 on the rear panel of the SDU-2000.

If you are installing only one SDU-2000, then attach the Expansion Terminator to either J15 or J17, whichever is available.

4. Attach one end of the Backup Clock cable (part number 12013115-xxx-0; the xxx indicates the length of the cable) to J9 on the rear panel of the SSU-2000.



Caution: To avoid damage to the J9 connector or the BNO tee connector, be sure to align its internal pins with the mating connector. The tee connector *does not* rotate once it is installed. If J9 is damaged, you will have to replace the entire shelf.

5. Install a BNO tee connector (part number 551095-0001) on J16 on the rear panel of the SDU-2000.
6. Attach the other end of the Backup Clock cable to the tee connector on J16.
7. Set the Clock Termination switch S2 to the 120 Ohms position.
8. Set the Shelf Address switch S1 to the 2 position.

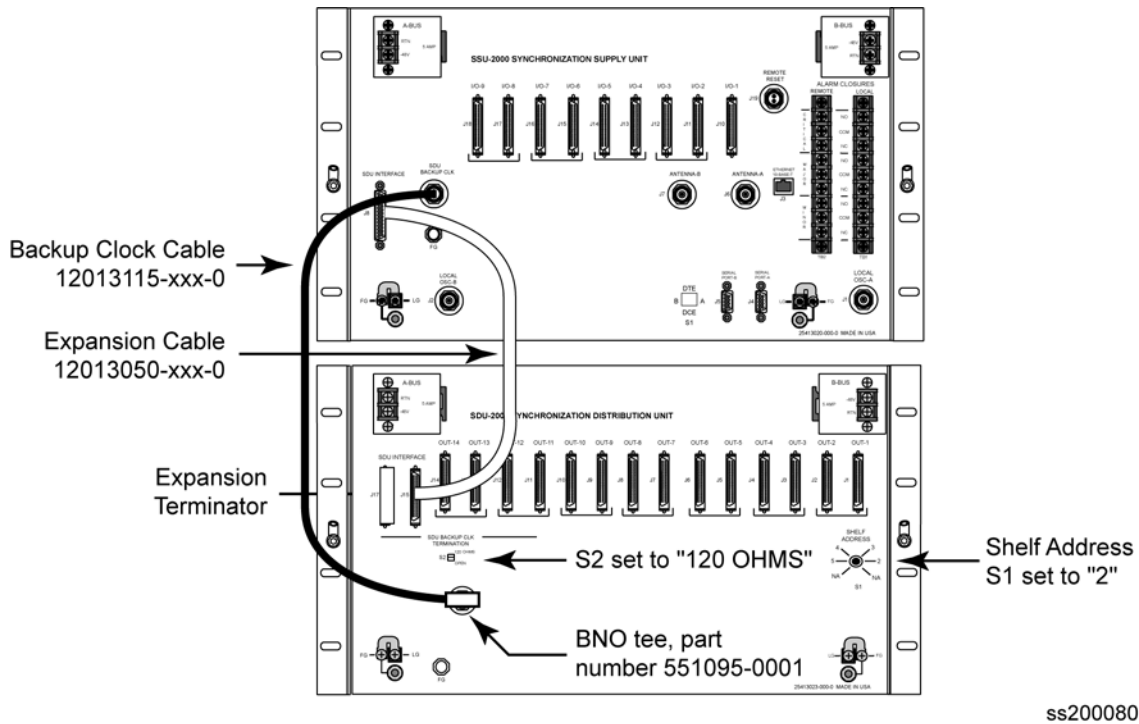

Figure 2-11. Wiring Diagram for a Single SDU-2000 Shelf

Connecting Additional SDU-2000 Expansion Shelves

To connect additional SDU shelves to an SDU, use the following procedure. [Figure 2-12](#) illustrates the wiring for a system with three SDU-2000 shelves.

1. Remove the Expansion Terminator (if installed) from J17 or J15 on the rear panel of the SDU-2000.
2. Attach one end of the Expansion Cable (part number 12013050-xxx-0; the xxx indicates the length of the cable) to either J17 or J15 on the rear panel of the first SDU-2000 shelf, whichever is available.
3. Attach the other end of the Expansion Cable to either J17 or J15 on the rear panel of the second SDU-2000 shelf.

If you are not installing a third SDU-2000, then attach the Expansion Terminator to either J17 or J15 of the second shelf, whichever is available.

4. Set the Clock Termination switch S2 on the rear panel of the first SDU-2000 to the Open position.



Caution: To avoid damage to the BNO tee connector, be sure to align its internal pins with the mating connector. The tee connector does not rotate once it is installed. If J9 is damaged, you will have to replace the entire shelf.



Note: Perform step 5 below only if a BNO tee connector is not installed on J16 on the first SDU-2000 shelf. If a tee connector is installed, skip to step 6.

5. Remove the Backup Clock cable from J16 on the rear panel of the first SDU-2000 shelf. Install a BNO tee connector (part number 551095-0001) to J16. Reconnect the Backup Clock cable to the tee connector.
6. Install a BNO tee connector (part number 551095-0001) to J16 on the rear panel of the second SDU-2000 shelf.
7. Attach one end of a second Backup Clock cable (part number 12013115-xxx-0; the xxx indicates the length of the cable) to the tee connector on J16 of the first SDU-2000 shelf
8. Attach the other end of the Backup Clock cable to the tee connector on J16 on the second SDU-2000 shelf.
9. Set the Clock Termination switch S2 on the rear panel of the second SDU-2000 to the 120 Ohms position.



Note: For installations with multiple SDU-2000 shelves, set S2 on all shelves to Open, except for the last shelf in the chain; set S2 on this shelf to 120 Ohms.

10. Set the Shelf Address switch S1 on the rear panel of the second SDU-2000 shelf to the 3 position.



Note: For installations with multiple SDU-2000 shelves, set S1 on each shelf to the number corresponding to the shelf's position in the chain.

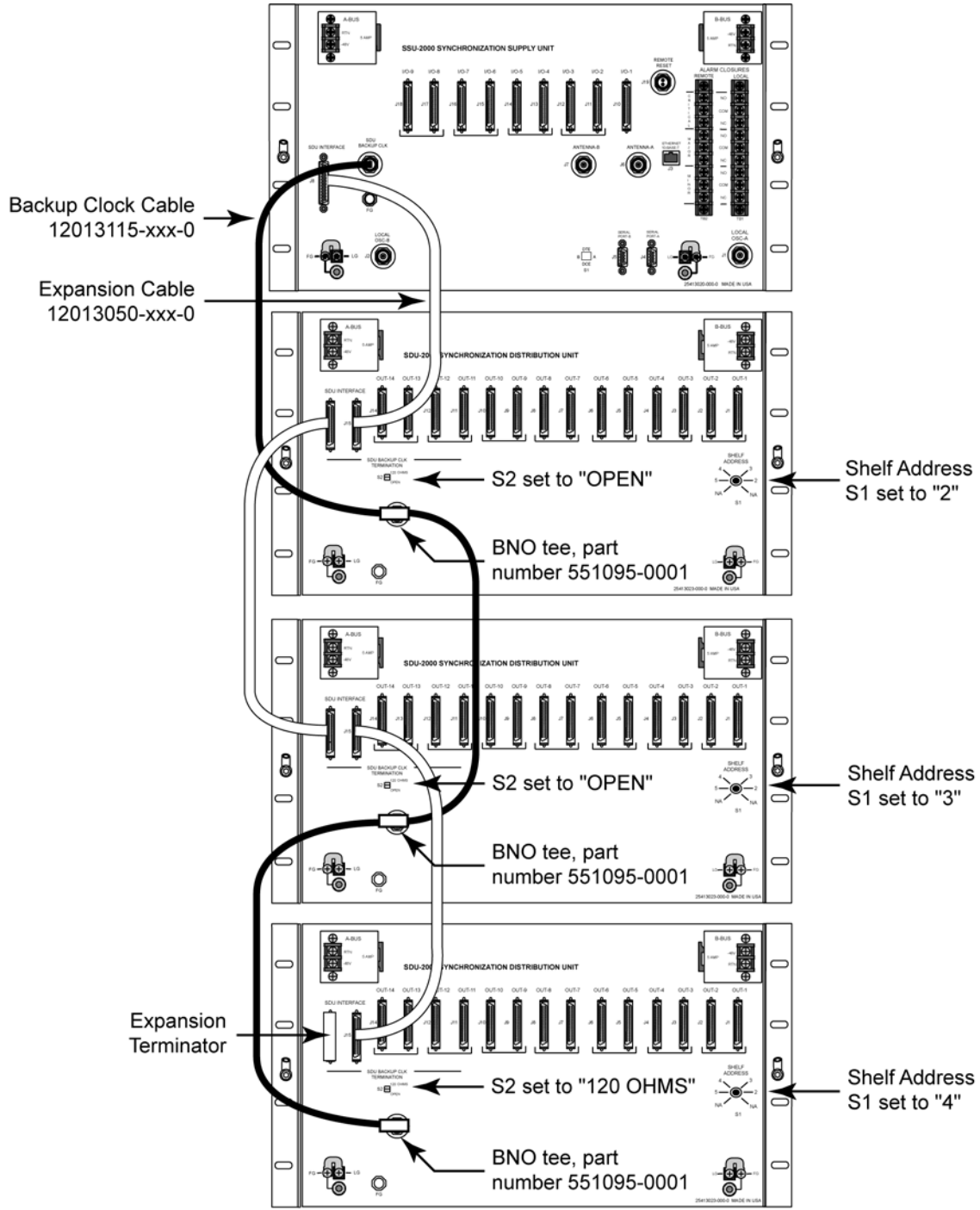

ss200081

Figure 2-12. Wiring Diagram for Multiple SDU-2000 Shelves

Handling Modules

The SSU-2000 shelf has twelve plug-in module slots, numbered A1 through A12, from left to right looking at the front of the shelf. Each module slot has a specific address and has two hybrid DIN connectors associated with it on the backplane. The hybrid contacts of these connectors are used for Power, Logic Ground, Frame Ground and RF connections. Each module slot has three pins connected together on each hybrid DIN connector which are to detect module removal.



Caution: To avoid equipment damage due to poor ventilation and EMI considerations, each slot in the SDU-2000 must contain either a module or blank filler panel. Filler panels are available for unpopulated slots.

Take the following precautions when handling any of the modules:

1. Use proper static control precautions when handling modules! Protect the equipment against ESD (electrostatic discharge) by using a grounded protective wrist strap and normal equipment grounding. Two ground connectors are provided on the side of the unit to connect these straps to frame ground (one on each mounting bracket).
2. Avoid touching component leads and edge connectors.
3. Avoid placing the module on an ungrounded surface.
4. Avoid allowing the module to come in contact with insulated surfaces.

Installing a Module

This procedure is common for all modules.



Note: Modules can be removed and inserted while system power is supplied without damaging modules or affecting system operation.



Caution: For continued EMC compliance, replace all deformed module gaskets with the same type. Clean gaskets and mating surfaces. Secure all modules with captive screws.

To install a module:

1. Align the module card edges with the plastic card guides of the selected slot.
2. Slide the module into the shelf until it seats fully into its rear panel edge connector.
3. Tighten the captive screws located at the top and bottom of the module front panel.



Caution: To avoid possible damage and intermittent failures, ensure that you have completely inserted the module into the system and that you have securely tightened the captive screws.

4. Enable the module using either ICS or TL1 commands. The example commands are for slot 3 in the main shelf.

ICS command:

Type `CONFIG 1A3 ENABLE`, then press **Enter**.

TL1 command:

`ACT-MODULE::S1A3:123;`

Exchanging a Module

Use this procedure to exchange one type of module with the same type or a different type of module in the same slot. The example commands are for slot 3 in the main shelf.

1. Connect to the SSU-2000 using one of the methods described in [Establishing a Connection With the SSU-2000](#), on page 90. The system prompts for a user name.
2. Log in to the system using your user name and password.
3. Disable the module using either ICS or TL1 commands. The example commands are for slot 3 in the main shelf.

ICS command:

Type `CONFIG 1A3 DISABLE`, then press **Enter**.

TL1 command:

`DISC-MODULE::S1A3:123;`

4. Loosen the captive screws located at the top and bottom of the module front panel.
5. Pull up on the top extractor and down on the bottom extractor to unseat the module from the connector on the backplane.

- Slide the module out of the shelf.
- Insert the new module into slot 3 of the main shelf. Tighten the captive screws on the front panel of the module. Wait for the “module installed” message to appear.



Note: Be sure that the I/O Adapter port is of the proper type and impedance for the new module.



Caution: To avoid possible damage and intermittent failures, ensure that you have completely inserted the module into the system and that you have securely tightened the captive screws.

- Enable the module using either TL1 or ICS commands:

ICS command:

Type `CONFIG 1A3 ENABLE`, then press **Enter**.

TL1 command:

`ACT-MODULE::S1A3:123;`

- Verify that the module is entered in the registry:

ICS command:

Type `CONFIG`, then press **Enter**.

TL1 command:

`RTRV-INV:::123;`

Disabling a Module

Use this command to temporarily disable a module without removing it from the SSU-2000 registry. All outputs from the disabled module will turn off, unless a summer adapter is installed on the I/O connector on the rear panel of the shelf. The example commands are for slot 3 in the main shelf.

- Connect to the SSU-2000 using one of the methods described in [Establishing a Connection With the SSU-2000](#), on page 90. The system prompts for a user name.
- Log in to the system using your user name and password.
- Disable the module using either ICS or TL1 commands:

ICS command:

Type `CONFIG 1A3 DISABLE`, then press **Enter**.

TL1 command:
DISC-MODULE::S1A3:123;

Removing Modules

This procedure describes how to permanently remove a module from the shelf.



Note: Modules can be removed and inserted while system power is supplied without damaging modules or affecting system operation.

1. Connect to the SSU-2000 using one of the methods described in [Establishing a Connection With the SSU-2000](#), on page 90. The system prompts for a user name.
2. Log in to the system using your user name and password.
3. Disable the module using either ICS or TL1 commands. The example commands are for slot 3 in the main shelf.

ICS command:
Type `CONFIG 1A3 DISABLE`, then press **Enter**.

TL1 command:
DISC-MODULE::S1A3:123;

4. Loosen the captive screws located at the top and bottom of the module front panel.
5. Pull up on the top extractor and down on the bottom extractor to unseat the module from the connector on the backplane.
6. Slide the module out of the shelf.
7. Install a blank filler panel to cover the empty slot.
8. Remove the module from the registry using either ICS or TL1 commands:

ICS command:
Type `CONFIG 1A3 REMOVE`, then press **Enter**.

TL1 command:
RMV-MODULE::S1A3:123;

9. Verify that the module is not in the registry:

ICS command:
Type `CONFIG`, then press **Enter**.

TL1 command:
RTRV-INV:::123;

Installation Checklist

1. Unpack all equipment carefully and check it against the purchase order.
2. Remove the A-BUS and B-BUS fuses from the rear of the unit.
3. Ensure shelf and I/O adapters are securely attached to the mounting rack.
4. Ground the SSU-2000 using the Frame Ground lug.
5. Measure between ground and chassis and verify no voltage exists between them.
6. If an SDU-2000 Expansion shelf is not being installed, ensure that the J8 connection is connected to a terminator.
7. Connect office alarms to the REMOTE and LOCAL terminals with 18 AWG wire.
8. Insert modules and filler panels in designated slots. Use proper handling technique.
9. Connect primary power to A-BUS screws and secondary power to B-BUS screws.
10. Measure voltage at POWER A and POWER B (if used) and verify it is –38 to –72 VDC.
11. Insert the A-BUS and B-BUS fuses into the holders on the rear panel of the SSU-2000.
12. Verify all modules are receiving power and generating regulated DC outputs by checking that their POWER indicators are lit.
13. To ensure that both power inputs are valid, verify on the Communications or Buffer modules that the green POWER indicator on the front of the Communications module is on. Also verify that the –48V Power A and B LEDs are both green. If all these indicators are not green, refer to [Table 2-5](#) for the module color code indications. Refer to [Chapter 5, Maintenance and Troubleshooting](#), if you are unable to obtain the correct indications.

Table 2-5. Communications and Buffer Module LED Indications

LED	State	Indication
Power	On	At least one -48V Power Supply is connected
Power	Off	No -48V Power Supply A or B connected
-48V Power Supply A or B	On (Green)	Power Supply is connected
-48V Power Supply A or B	Off	No -48V Power Supply connected to the power supply input
-48V Power Supply A or B	On (Amber)	-48V Power polarity is reversed

Powering Up the SSU-2000

The SSU-2000 is *not* equipped with a Power switch. Power to the SSU-2000 is controlled by two 5-amp fuses located on the rear of the SSU-2000 main chassis as shown in Figure 2-13. To power down the shelf, remove *both* fuses.

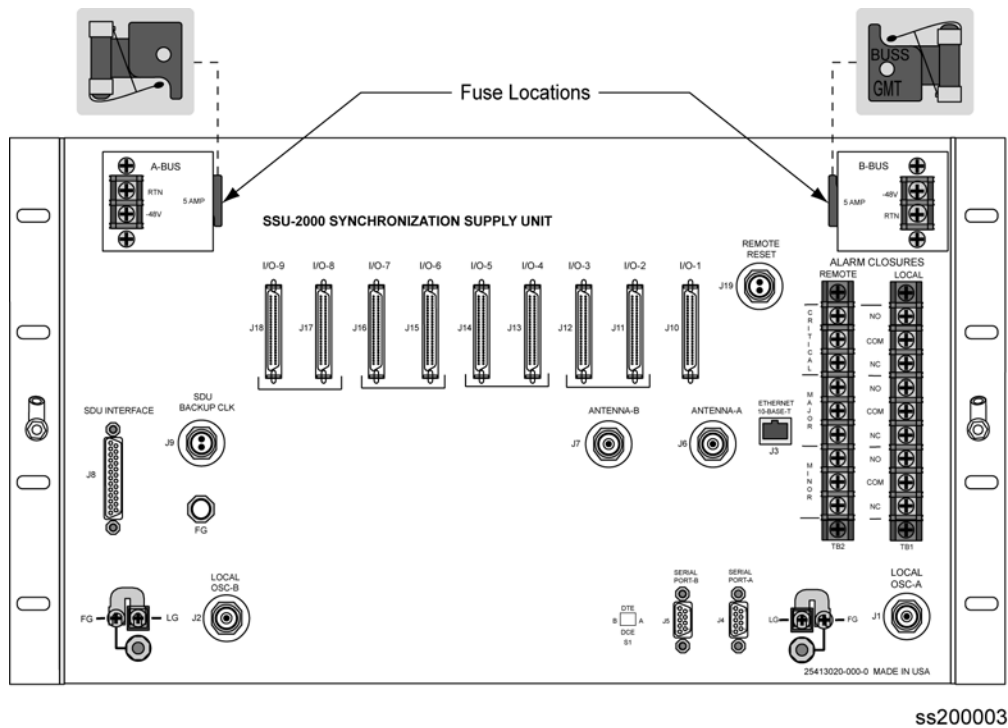

Figure 2-13. SSU-2000 Power Fuses

SSU-2000 Main Shelf

To power up the SSU-2000 main shelf, insert the two fuses into the fuse slots on the rear panel of the SSU-2000 main chassis (see [Figure 2-13](#)).

SDU-2000 Expansion Shelf

The SDU-2000 expansion shelf is *not* equipped with a Power switch. Power to the SDU-2000 is controlled by two external power supplies that provide –48/60 VDC to the SDU-2000 main chassis (A-BUS and B-BUS) at connectors J101 and J102. To power up the shelf, turn the power on to both power supplies.

Normal System Indications During Turn-Up

This section describes the procedures for bringing the SSU-2000 on-line after completion of the system installation. After completion of the turn-up procedures, complete the commissioning tests in [Chapter 4, Commissioning](#) to ensure that the shelf is functioning properly.

As the shelf powers up and begins normal operation, the LEDs on the front of each of the installed modules go through a sequence as follows:

- Stratum 2E Clock Module – The POWER LED turns green and stays green when the fuses are installed in the Main chassis. The STATUS LED blinks green and amber for approximately 10 to 15 seconds and then stays green. The WARMUP LED turns amber for approximately 30 seconds to 5 minutes; it then turns off and the ACQUIRE LED turns green. The ACQUIRE LED stays green for 10 to 15 minutes until the module locks onto a signal, then the LED turns off. The SELECTED LED turns green on the selected clock module after the ACQUIRE LED on the clock module turns green. The LOCKED LED then turns green and stays green.
- Stratum 3E Clock Module – The POWER LED turns green when power is applied to the unit and stays green. STATUS LED blinks green and amber for approximately 10 to 15 seconds and then stays green. The WARMUP LED turns amber for 30 seconds to approximately 20 minutes, then it turns off and the ACQUIRE LED turns green. The ACQUIRE LED stays green until the module locks onto a signal (10 to 15 minutes); then the LED extinguishes. The SELECTED LED turns green on the selected clock module after the ACQUIRE LED turns green. The LOCKED LED turns green and stays green.

- **Communications Module** – The POWER LED turns green when power is applied to the unit and stays green. The STATUS LED blinks green and amber for approximately 10 to 15 seconds and then stays green. The -48V POWER LEDs A and B turn green to indicate that the power supplies are connected. If one of these LEDs are amber, the polarity of that power connection is reversed and needs to be switched. The three ALARM LEDs clear after ~1 minute. After initialization, if there are any alarms, it takes approximately 30 seconds to register and the ALARM LED turns amber. The ETHERNET LINK LED blinks green for approximately 30 seconds and stays green.
- **Input Module** – The POWER LED turns green when power is applied to the unit and remains green while the system is powered up. The STATUS LED blinks green and amber for approximately 10 to 15 seconds and then stays green. The PORT 1 REF LED blinks for approximately 5 to 10 seconds and turns green for the reference input and off for the others. The INPUT LED blinks for approximately 5 to 10 seconds and turns green for every valid input or amber for not valid inputs.
- **Output Module** – The POWER LED turns green when power is applied to the unit and stays green. The STATUS LED blinks green and amber for approximately 10 to 15 seconds and then stays green. The SOURCE LED turns green for the source clock, amber for an enabled clock that is not present and off for an enabled clock that is present but not the source clock.

After Turn Up

This completes the turn-up procedures. After completing the turn-up procedures perform the following:

- Assign a System Administrator and any additional users to the system using the procedures in [Adding An Administrator-Level User to the System](#), on page 95.
- Make any required changes to the factory default configuration settings as described in [Initial Provisioning](#), on page 105.
- Complete the commissioning tests in [Chapter 4, Commissioning](#), to ensure that the system is functioning properly.
- Refer to [Chapter 5, Maintenance and Troubleshooting](#), to clear any system alarms that might occur.

Chapter 3 Provisioning and Operating the SSU-2000

This chapter provides operating instructions and software provisioning procedures for the SSU-2000 system.

In This Chapter

- [Controls and Indicators](#)
- [Establishing a Connection With the SSU-2000](#)
- [Overview of the SSU-2000 Security System](#)
- [Adding An Administrator-Level User to the System](#)
- [Adding Users to the System](#)
- [Initial Provisioning](#)
- [Checking Alarm Status](#)
- [Factory Default \(Basic\) Configuration](#)

Controls and Indicators

SSU-2000 Status LED Indicators

All modules used in the SSU-2000 main chassis and in the optional SDU-2000 Expansion shelf contain status LED indicators that provide a visual indication of module status. The Communications module provides both system and individual module status whereas all other modules provide individual module status only. For more information on individual module status LED indicators, refer to [Chapter 6, Clock Module Reference Data](#), [Chapter 7, Input Module Reference Data](#), and [Chapter 8, Output Module Reference Data](#).

SSU-2000 Operating Controls

The SSU-2000 contains four hardware operating controls:

- Three DCE/DTE select switches associated with the three RS-232 ports. One switch is located on the front of the Communications module and the remaining two are located on the rear panel of the SSU-2000. The DCE position is for connection to a PC and the DTE position is for connection to a modem.
- Reset (RST) switch on the Communications module

All other controls on the SSU-2000 are software-based. To provision the settings, you must first connect to the SSU-2000 using a serial port or the Ethernet port.

Establishing a Connection With the SSU-2000

You can connect to the SSU-2000 using either a serial connection or an Ethernet connection. To connect via a serial port, see [Communicating by Serial Port](#), on page 91. If the SSU-2000 is connected to an Ethernet LAN, use the procedure described in [Connecting through the Ethernet LAN](#). Refer to [Table 3-1](#) for the serial and Ethernet communications port assignments.

Table 3-1. Communications Port Assignments

Port #	Function	Protocol
Serial Ports (EIA-232)		
A (J4)	This port is user selectable as either an ICS or a TL1 interface. The port defaults to ICS upon initialization	ICS (Default), TL1
B (J5)	This port is user selectable as either an ICS or a TL1 interface. The port defaults to ICS upon initialization	ICS (Default), TL1
Local (Comms Module)	This port is user selectable as either an ICS or a TL1 interface. The port defaults to ICS upon initialization	ICS (Default), TL1

Table 3-1. Communications Port Assignments (Continued)

Port #	Function	Protocol
Ethernet Ports (Telnet)		
23	This port is user selectable as either an ICS or a TL1 interface. The port defaults to ICS upon initialization	ICS (Default), TL1
123	This port is designated for NTP only	NTP
161	This port is designated for SNMP Interactive	SNMP Interactive
162	This port is designated for SNMP Trap transmission	SNMP Trap
2000	This port is designated for TL1 only	TL1

Communicating by Serial Port

Three EIA-232 ports are available on the SSU-2000. Attach a PC with terminal emulation software to one of the ports as shown in [Figure 3-1](#) (this example shows connecting to the local port on the front of the Communications module).

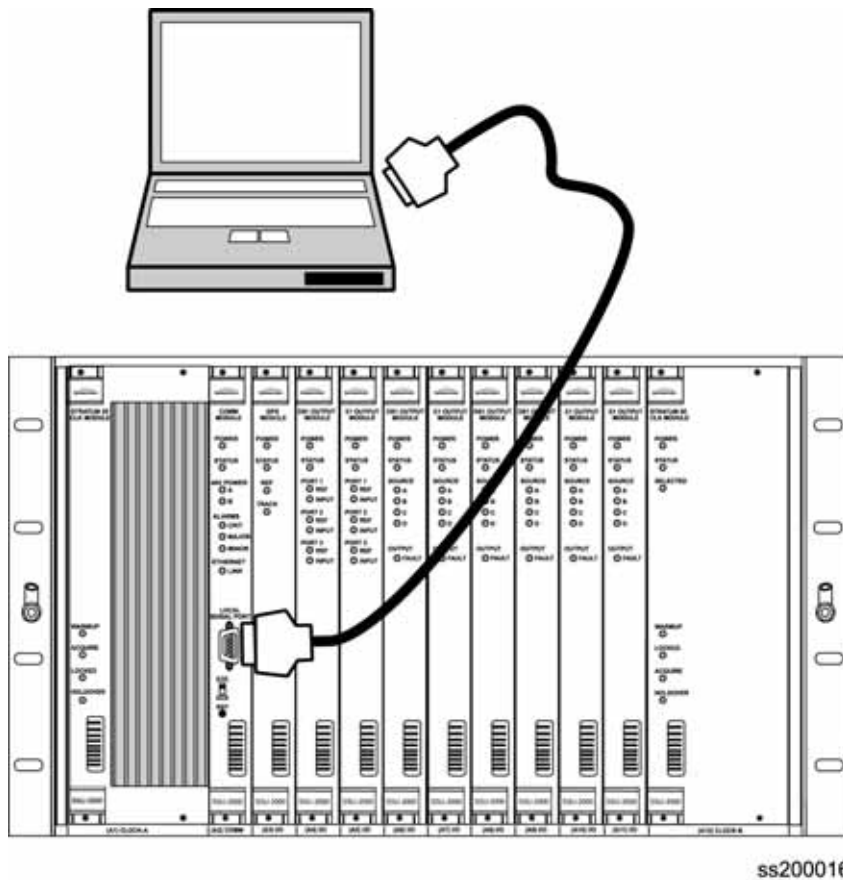

Figure 3-1. Direct Connection Using the Serial Port

1. Connect one end of the cable to the serial port on the computer or terminal and the other to the appropriate connector on the SSU-2000.
2. Set the DTE/DCE switch on the rear panel of the SSU-2000 for the type of cable (straight-through or modem).
3. Configure the emulation software for 8 data bits, no parity, 1 stop bit, and 9600 baud rate.
4. Start the terminal emulation software and press **Enter**. The system prompt -> should appear. If it does not, recheck each step in this procedure.
5. For the initial installation, create an Administrator-level user as described in [Adding An Administrator-Level User to the System](#), on page 95, before proceeding with the Ethernet setup.

Communicating by Ethernet

To communicate with the SSU-2000 using an Ethernet LAN, you must first configure the Ethernet port. This section describes how to configure the Ethernet port and then connect to the SSU-2000 using the Ethernet port.

When you connect to the SSU-2000 via Ethernet port 2000 (decimal) using a Telnet-type application, the session opens in TL1 mode. Up to four sessions (users) can be connected to port 2000 at one time. Once you are connected, you must log in using the ACT-USER command with a user name and password (if security is active on the unit).

To log off the user and exit from an Ethernet session, type `CANC-USER:::0;`. Another user can then open a new session by using the ACT-USER command.

To log off the user, exit from an Ethernet session, and close the Ethernet connection to port 2000, type `EXIT:::0;`. The next user must first connect to port 2000 and then log in using the ACT-USER command.

Configuring the Ethernet Port

Use the following procedure to configure the SSU-2000 Ethernet parameters (IP Address, Subnet Mask, and Gateway Address).

1. Establish a direct serial connection to the SSU-2000 as described in [Communicating by Serial Port](#), on page 91.
2. Provision the IP, Gateway, and Subnet addresses for the SSU-2000. The IT department or site administrator for your location can recommend specific addresses for these parameters. Use the format xxx.xxx.xxx.xxx for the address.

ICS commands:

Type `IP ADDR [ip address]` then press **Enter**.

Type `IP GATEWAY [gate address]` then press **Enter**.
Type `IP SUBNET [subnet address]` then press **Enter**.

TL1 command:

```
SET-PRMTR-IP:::123::[ip address],[gate address],[subnet address];
```

3. Restart the Communications module:

ICS command:

Type `restart 1A02`, then press **Enter**.

TL1 command:

```
RST-MODULE::S1A2:123;
```

4. Verify that the information is correct:

ICS command:

Type `ip`, then press **Enter**.

TL1 command:

```
RTRV-PRMTR-IP:::123;
```

Connecting through the Ethernet LAN

After the Ethernet port is configured, use the following procedure to connect to it:

1. Ensure that the SSU-2000 is connected to a LAN. See [Making Ethernet Connections](#), on page 72 for details.
2. Telnet from your PC to the IP address assigned to the SSU-2000.
3. Type your user name and press **Enter**. If you are not assigned as a user in the system, contact the System Administrator.
4. Enter your assigned password and press **Enter**. The system prompt appears.

Overview of the SSU-2000 Security System

The operating software of the SSU-2000 includes a subset of GR-815 security requirements, including user lockout, password aging, and login failure attempts. New commands allow an Administrator-level user to query the security log, set the login failed attempts threshold, set user lockout timer, and set the password-aging timer. New commands also allow you to back up and restore the configuration in the shelf. See the *SSU-2000 Technical Reference* for details on the security commands.

Passwords must have at least one alphanumeric, one numeric, and one special (punctuation, for example) character. The user must create a new password after the specified password aging period has elapsed; the new password cannot be the same as any of the previous three passwords. The user must confirm entry of a new password by re-typing the password.

If a user fails to enter a correct password in a preset number of attempts, that user is locked out from further attempts to log in for a specified amount of time, and an entry is made in the security log. An Administrator-level user can set the number of attempts, the lock-out period, and password aging.

A security log maintains a record of each login attempt, successful logins, and log-outs. Other events stored in the log including adding and changing users, changes to a user's profile (password and/or access level), enabling and disabling a user, or changes to the password aging period. The log records the date and time of each entry, the user ID, and the session type. Passwords are not stored in the security log. This log is stored in non-volatile memory, and cannot be modified or deleted by any user.

In order to use the security features, the hardware and firmware in the SSU-2000 must be as shown in [Table 3-2](#).

Table 3-2. Firmware Requirements for Security Features

Module	Module Part Number	Hardware Revision Required ¹	Firmware Code Part Number
Communications module	23413012-00x-0	A.00 or higher	14313012-000-5 Rev. M.00
Clock modules	23413015-00x-0 23413016-000-0	A.00 (JCC ² : B.00) or higher A.00 (JCC: A.10) or higher	14313015-000-5 Rev. M.00

Note:

¹ The hardware revision is on a label located on the front panel. You can display the hardware revision by issuing the TL1 command RTRV-INV, or the ICS command CONFIG.

² JCC = Japan Composite Clock

The SSU-2000 system software allows you to set up a list of users with one of five access levels; each level has an increasing level of access to system functions and commands. Each incremental access level incorporates all of the options from the lower numbered access levels and additional options at that level. For instance, a User-level user does not have as many options available as a Technician-level user.

An Administrator-level user assigns the access level to each user when the user id and password is created. [Table 3-3](#) summarizes each access level, ID number, and the operator privileges for each level.

Table 3-3. User Access Levels

Level	ID	Description
Idle	0	Access level 0 is available when no user is logged in. This level allows Idle-level users to view a list of available commands (HELP), syntax, software version number, unit id, or to login.
User	1	Users at the User level can view information about the current configuration and operation, and change communication settings such as line termination and echo. Changes made by a User-level user remain in effect only until the user logs out.
Technician	2	Users at the Technician level (CRAFT persons) can perform all level 1 functions, and can read or set all installation functions.
Supervisor	3	Supervisor-level users can execute all commands at levels 1 through 2, and can read or set all functions.
Administrator	4	Administrator-level users can execute all levels of commands; they can view and set software configurations; they can also add, delete, or modify the user table, or log off any user from any port.

Adding An Administrator-Level User to the System

An Administrator-level user must be added to the user list when you log in for the first time. This user performs initial setup and can assign user privileges and passwords as needed, as well as configuring all system parameters.



Caution: You must add an Administrator-level user and password before adding any other users. If you add a user that is not at the Administrator security level before adding the administrator, you will not be able to log into the unit at that level again without a service call.

Perform the following steps to add an Administrator-level user to the system.

1. Establish a direct serial connection to the SSU-2000 as described in [Communicating by Serial Port](#), on page 91.
2. Type `admin` at the username prompt for the first-time system login (otherwise enter your username) and press **Enter**. The system prompts for a password.
3. Press **Enter** for the first-time system login (otherwise enter your password) and press **Enter**. The system prompt appears.
4. Type `user add` and press **Enter**. The system prompts you for a user name.

5. Enter a “username” and press **Enter**. The name you enter will be the log-in name for the system administrator. You can use up to 20 characters for the user name. The system prompts you for a password.
6. Enter a “password” and press **Enter**. Passwords must have at least one alphanumeric, one numeric, and one special (punctuation, for example) character. The password can be up to 10 characters long. The password you enter will be the log-in password for the system administrator. The system prompts you to confirm the password by retyping it.
7. Retype the password and press **Enter**. The system prompts for an access level.
8. Type 4 and press **Enter**. This selects the Administrator access level. The system prompt appears.
9. Type `bye` and press **Enter** to log off the system.
10. Type `login` followed by the administrator's user name and password and press **Enter**. This verifies that the account exists.
11. Type `bye` and press **Enter** to log off the system.

Adding Users to the System

Only an Administrator-level user can add new users to the SSU-2000 user list. You can use ICS or TL1 commands.

Using ICS Commands

1. Connect a computer to an ICS port on the SSU-2000 and log in using an Administrator-level user name and password, as described in [Logging In to the SSU-2000](#), on page 102.
2. Type `USERS ADD` then press **Enter** to create a new user account. The system prompts for the new username.
3. Type in the new username, then press **Enter**. The system prompts for the new user's password.
4. Type in the new user's password and press **Enter**. The system prompts you to confirm the password by retyping it.
5. Type in the new user's password and press **Enter**. The system prompts for an access level.
6. Type in the new user's access level (a number between 1 and 4, inclusive), and press **Enter**. The following text shows the dialog for creating a new level-1 user with the name david1:

```
SSU_2000->users add
Username: DAVID1
Password: *****
Confirm: *****
Access: 1
2006-02-22T16:49:55 1A02 Rep Add User, DAVID1, TELA
SSU_2000+>
```

7. Type `users` and press **Enter** to display the user table. The system responds with a list similar to the following:

```
2006-02-23T22:01:45 ID: SSU2000, Name: SSU_2000
Password Aging: Enable
User Lockout: Enable

User Name          Level User Password DaysLeft Lock
-----
ADMIN              4    ENA  ALIVE    23      NO
DAVID              4    ENA  ALIVE    28      NO
DAVID1            1    ENA  ALIVE    29      NO
SSU_2000->
```

Using TL1 Commands

1. Connect a computer to port 2000 on the SSU-2000 and log in using an Administrator-level user name and password, as described in [Logging In to the SSU-2000](#), on page 102.
2. Type `SET-USER:::123::ADD,FRANK1,ABC123!,1;` to add a user named `FRANK1` with a password of `ABC123!` at the User level. The system responds with:

```
SSU_2000 06-02-21 20:07:21
M 123 COMPLD
"\PASSWORD CONFIRMATION REQUIRED, SET-PWD-CONFIRM\" "
;
```

3. Type `SET-PWD-CONFIRM:::123::ABC123!;` to confirm the new password. You *must* issue the `SET-PWD-CONFIRM` command immediately after the `SET-USER` command in order to validate the `SET-USER` command. The system responds with:

```
SSU_2000 06-02-21 20:21:41
A 000001 REPT EVT
"S1A02:NA,193,NSA,06-02-21,20-21-41:\Add User, FRANK1,
TL1B\" "
;
```

4. Type `RTRV-USER:::123;` to display a list of users in the system. The system responds with:

```
SSU_2000 06-02-22 14:32:40
M 123 COMPLD
"ADMIN,4,ENA,ALIVE,23,NO"
"DAVID,4,ENA,ALIVE,28,NO"
"DAVID1,1,ENA,ALIVE,29,NO"
"FRANK1,1,ENA,ALIVE,29,NO"
;
```

where the format for the list of users is `username, level, password State, password days left, lockout`.

Setting Security Parameters

Only an Administrator-level user can access security parameters for the SSU-2000. You can use ICS or TL1 commands to set the security parameters, which include the following:

- Setting the Number of Failed Attempts Counter – if a user cannot log in correctly within this number of attempts, that user is then prevented from further attempts for the period specified in the Lockout time parameter.
- Setting the Lockout Time – When a user has exceeded the number of failed login attempts, that user is prevented from further attempts to log in for the period specified in this parameter.
- Setting the Password Aging – A user's password is valid for the number of days specified in this parameter. If the user attempts to log in after this number of days, the user must create a new password.
- Viewing the Security Log – The security log contains information related to the security of the system, such as the login attempts, successful logins, logouts, etc.
- Setting User Parameters, such as:
 - Changing a Password
 - Changing Access Level
 - Deleting a User
 - Setting a Temporary Password
 - Enabling, Disabling, and Unlocking Users

Using ICS Commands

1. Connect a computer to a serial port on the SSU-2000 and log in using an Administrator-level user name and password, as described in [Logging In to the SSU-2000](#), on page 102.
2. Type `SECURITY FAIL 3` and press **Enter** to set 3 as the number of failed login attempts before disabling the user account.
3. Type `SECURITY LOCKOUT 60` and press **Enter** to set the lockout time to 60 seconds.

4. Type `SECURITY AGING 30` and press **Enter** to set the password to expire in 30 days.
5. Type `SECURITY LOG 10` then press **Enter** to display the last 10 entries in the Security log. The log appears as shown:

```
SSU_2000->security log 10
2006-02-22T18:41:29 ID: SSU2000, Name: SSU_2000
Time Stamp          Description          Information
-----
2006-02-22T17:11:04 LOGIN              ENET, TL1, DAVID1
2006-02-22T17:12:18 CHANGE_PASSWORD   ENET, TL1, DAVID1
2006-02-22T17:16:34 LOGIN_FAIL        ENET, TL1, ADMIN
2006-02-22T17:21:20 LOGOUT            ENET, TL1, DAVID1
2006-02-22T17:31:48 LOGIN_FAIL        ENET, TL1, ADMIN
2006-02-22T17:47:01 LOGIN_FAIL        ENET, TL1, ADMIN
2006-02-22T18:02:10 LOGIN_FAIL        ENET, TL1, ADMIN
2006-02-22T18:17:19 LOGIN_FAIL        ENET, TL1, ADMIN
2006-02-22T18:32:32 LOGIN_FAIL        ENET, TL1, ADMIN
2006-02-22T18:41:24 LOGIN              ENET, ICS, DAVID
SSU_2000->
```

Changing a User's Password

1. Type `USERS PWD` then press **Enter** to change a password. The system prompts for the user name that is to receive the new password.
2. Type the user name, then press **Enter**. The system prompts for the new password.
3. Type the new password, then press **Enter**. The system prompts you to confirm the new password.
4. Retype the new password, then press **Enter**. If you do not type the new password exactly the same, the command fails.

Setting a Temporary Password

An Administrator-level user can create a temporary password for a user. When a user logs in using the temporary password, that user must create a new password before continuing.

1. Type `USERS TEMPPWD` then press **Enter** to create a temporary password. The system prompts for the user name that is to receive the new password.
2. Type the user name, then press **Enter**. The system prompts for the password.
3. Type the new password, then press **Enter**. The system prompts you to confirm the password.
4. Retype the new password, then press **Enter**. If you do not type the new password exactly the same, the command fails.

Changing a User's Access Level

1. Type `USERS ACCESS` then press **Enter** to change a user's access level. The system prompts for the user name that is to receive the new access level.
2. Type the access level (1 through 4), then press **Enter**.

Deleting a User

1. Type `USERS DEL` then press **Enter** to delete a user from the user table. The system prompts for the user name that you want to delete.
2. Type the user name, then press **Enter**. The system deletes the user from the user table.

Enabling, Disabling, and Unlocking Users

An Administrator-level user can enable or disable a user from accessing the SSU-2000 without removing the user name from the user table. If a user exceeds the number of failed attempts to log in, then the user name is locked for a period of time. An Administrator-level user can unlock the user name and allow the user to attempt to log in, overriding the Lockout Time parameter.

1. Type `USERS DISABLE` then press **Enter** to disable a user from accessing the SSU-2000. The system prompts for the user name that you want to disable.
2. Type the user name, then press **Enter**. The system disables the user.
3. Type `USERS ENABLE` then press **Enter** to allow a user to access the SSU-2000. The system prompts for the user name that you want to enable.
4. Type the user name, then press **Enter**. The system enables the user.
5. Type `USERS UNLOCK` then press **Enter** to unlock a user name. The system prompts for the user name that you want to unlock.
6. Type the user name, then press **Enter**. The system unlocks the user.

Using TL1 Commands

1. Connect a computer to port 2000 on the SSU-2000 and log in using an Administrator-level user name and password, as described in [Logging In to the SSU-2000](#), on page 102.
2. Type `SET-PRMTR-SECU:::123::3,60,60;` to set to 3 the number of failed login attempts before disabling the user account, to set the lockout time to 1 minute, and to set the password to expire in 60 days. The system responds with:

```
SSU_2000 06-02-21 20:27:35
A 000002 REPT EVT
  "S1A02:NA,215,NSA,06-02-21,20-27-35:\"Security, Lockout, 60, TL1B\" "
;
```

3. Type `RTRV-SEC-LOG:::123::10;` to display the 10 most recent security log events.

Changing a User's Password

1. Type `SET-USER:::123::PWD,username,password;` to change the password for the specified user.
2. Type `SET-PWD-CONFIRM:::123::password;` to confirm the new password. You *must* issue the SET-PWD-CONFIRM command immediately after the SET-USER command in order to validate the SET-USER command.

Setting a Temporary Password

An Administrator-level user can create a temporary password for a user. When a user logs in using the temporary password, that user must create a new password before continuing.

1. Type `SET-USER:::123::TMP,username,pwd;` to create a temporary password for the specified user.
2. Type `SET-PWD-CONFIRM:::123::pwd;` to confirm the temporary password. You *must* issue the SET-PWD-CONFIRM command immediately after the SET-USER command in order to validate the SET-USER command.

Changing a User's Access Level

Type `SET-USER:::123::ACC,username,,level;` to change the access level for the specified user.

Deleting a User

Type `SET-USER:::123::DEL,username;` to delete the specified user from the user table.

Enabling, Disabling, and Unlocking Users

An Administrator-level user can enable or disable a user from accessing the SSU-2000 without removing the user name from the user table. If a user exceeds the number of failed attempts to log in, then the user name is locked for a period of time. An Administrator-level user can unlock the user name and allow the user to attempt to log in, overriding the Lockout Time parameter.

1. Type `SET-USER:::123::DIS,username;` to disable the specified user from accessing the SSU-2000.
2. Type `SET-USER:::123::ENA,username;` to allow a user to access the SSU-2000.
3. Type `SET-USER:::123::UNL,username;` to unlock a user name.

Logging In to the SSU-2000

Using ICS Commands

1. Connect a computer to a serial port on the SSU-2000 using the procedure in [Establishing a Connection With the SSU-2000](#), on page 90. A prompt to enter a username appears.
2. Type your user name (or use `ADMIN`, the default Administrator-level user name) then press **Enter**. The system prompts for a password.
3. Type your password (or use `SSU-2000`, the default password) then press **Enter**. The following text appears followed by the system prompt, showing that you have access to the system.

```
pSOSystem (172.16.21.19)

Username: ADMIN
Password:
Symmetricom Technical Support
1-888-367-7966 toll free USA
1-408-428-7907 worldwide
SSU_2000, 2006-02-23T21:49:32 DOY:54
14313012-005-5, F.00, 02FEB06

!!!!!!!!!!!!!!!!!!!!!!!!!!!!!!!!!!!!!!!!!!!!!!!!!!!!!!!!!!!!!!!!!!!!!!
NOTICE: THIS IS A PRIVATE COMPUTER SYSTEM.
UNAUTHORIZED ACCESS OR USE MAY LEAD TO PROSECUTION.
!!!!!!!!!!!!!!!!!!!!!!!!!!!!!!!!!!!!!!!!!!!!!!!!!!!!!!!!!!!!!!!!!!!!!!

SSU_2000->
```

Using TL1 Commands

1. Connect a computer to port 2000 on the SSU-2000 using the procedure in [Establishing a Connection With the SSU-2000](#), on page 90.
2. Press the ; key to ensure you have a connection. With an active connection, the system responds with a DENY message:

```
SSU_2000 06-02-23 21:54:06
M 0 DENY
IITA
;
```

3. Type `ACT-USER::username:123::pwd;` to log in to your account, where `username` is your user name and `pwd` is your password, or type `ACT-USER::admin:123::SSU-2000;` to log in, where `ADMIN` is the default user name and `SSU-2000` is the default password. The following text appears followed by the system prompt, showing that you have access to the system.

```
SSU_2000 06-02-23 21:54:35
```

Logging Off of the SSU-2000

Use one of the following commands to log off of the SSU-2000:

Using ICS commands

Type `bye` and press **Enter**.

Using TL1 commands

`CANC-USER:::123;`

Initial Provisioning

After you have established communications with the SSU-2000, you must provision the unit so it can track the input signals and start generating outputs. This sections contains general instructions for initial provisioning of the SSU-2000, and are not intended to cover all combinations of Input and Output modules. You may need to alter the commands in this section to match the configuration of your SSU-2000.

Provisioning General Parameters

This section describes how to provision the reference mode and the auto-return mode, set the IP address, and name the unit.

1. Log in to the SSU-2000 using the procedure in [Logging In to the SSU-2000](#), on page 102.
2. Provision the reference selection mode. The default is Priority, which is the most widely used mode. See [Selecting the Input](#), on page 28, for information on selecting the appropriate mode.

ICS command:

Type `REF PRI`, then press **Enter**.

TL1 command:

Type `SET-INPUT-REF:::123::port,PRI;`

where 123 is an arbitrary ctag value and `port` is the selected input port in the format `S1Ax[-z]`, where `x` is the slot number (3–12) and `z` is the port (1–3).

Repeat this command for all inputs.

3. Provision the clocks to enable auto-return (revertive) mode. Symmetricom generally recommends that auto-return be set to On, unless both clocks are of the same Stratum level. See [Setting the Reference Switching Mode](#), on page 29, for more information on revertive and non-revertive modes.

ICS command:

Type `CLK AR ON`, then press **Enter**.

TL1 command:

```
SET-CLK-AR:::123::ON;
```

4. Assign a name, if desired, to the SSU-2000. You can assign a [name] of up to 20 characters, starting with a letter; the name is returned as the `tid` in responses from the unit.

ICS command:

Type `NAME [name]`, then press **Enter**.

TL1 command:

```
SET-NAME:S1A2::123::[name];
```

You can also use this command to assign a name to inputs and outputs.

Adding or Enabling a Module

Use this procedure when replacing one type of module with a different type of module in the same slot. The following example procedure adds a Clock module to shelf 1, slot 12.

1. Insert the module into slot 12 of the main shelf.
2. Log into the SSU-2000 using the procedure in [Logging In to the SSU-2000](#), on page 102.
3. Enable the module:

ICS command:

Type `config 1A12 enable`, then press **Enter**.

TL1 command:

```
ACT-MODULE::S1A12:123;
```

4. Verify that the module is registered:

ICS command:

Type `config` and press **Enter**.

TL1 command:

```
RTRV-INV:::123;
```

5. Log off the SSU-2000 when you're finished.

Disabling a Module

Use this command to temporarily disable a module without removing it from the system. The following example procedure disables the module in shelf 1, slot 12.

1. Log into the SSU-2000 using the procedure in [Logging In to the SSU-2000](#), on page 102.

2. Disable the module:

ICS command:

Type `config 1A12 disable` and press **Enter**.

TL1 command:

`DISC-MODULE::S1A12:123;`

3. Log off the SSU-2000 when you're finished.

Removing a Module

Use this procedure to permanently remove a module from the system. If a module has been unplugged from the system, this command can also be used to clear the module's active alarms. The following example procedure removes the B Clock module in shelf 1, slot 12 from the registry.

1. Log into the SSU-2000 using the procedure in [Logging In to the SSU-2000](#), on page 102.

2. Remove the module from the database:

ICS command:

Type `config 1A12 remove` and press **Enter**.

TL1 command:

`RMV-MODULE::S1A12:123;`

3. Verify that the module is not in the registry:

ICS command:

Type `config` and press **Enter**.

TL1 command:

`RTRV-INV:::123;`

4. Log off the SSU-2000 when you're finished.

Provisioning GPS Input Modules

This section describes how to enable GPS Input modules, if they are installed. You must assign a priority level to each module. You can install GPS Input modules only in slot 3 and slot 5 of the main SSU-2000 shelf.

1. Log into the SSU-2000 using the procedure in [Logging In to the SSU-2000](#), on page 102.

2. Enable the modules:

ICS command:

Type `INPUT 1A3 ENABLE`, then press **Enter**.

Type `INPUT 1A5 ENABLE`, then press **Enter**, if a module is present in slot 5.

TL1 command:

See the command in step 2, below.

3. Set the priority level for each module.

ICS command:

Type `INPUT 1A3 PRI 1` then press **Enter**.

Type `INPUT 1A5 PRI 1` then press **Enter**, if a module is present in slot 5.

TL1 command:

`SET-PRMTR-INPUT::S1A3:123::ON,1;`

enables the module in slot 3 and sets its Priority to 1.

`SET-PRMTR-INPUT::S1A5:123::ON,1;`

enables the module in slot 5 and sets its Priority to 1.

4. Provision the MTIE limits for each input port according to ITU (G.811 or G.823) or ANSI (PRS or DS1) specifications.

ICS command:

Type `INPUT 1Ay MTIE PRS|DS1|G.811|G.823` then press **Enter**
where y is slot number 3 or 5.

TL1 command:

`SET-PRMTR-MTIE::S1Ay:123::{EL1|EL2|CL1|CL2},[t10],[t100],`
`[t1k],[t10k],[t100k];`

where y is slot number 3 or 5 and alarm thresholds EL1 or EL2 and the clear thresholds CL1 or CL2. Threshold settings t10 through t100k are the error limits in nanoseconds for the measurement time period.

Provisioning Other Input Modules

This section describes how to enable and provision other types of Input modules such as DS1, E1, or Composite Clock. You must enable and provision each input port as appropriate for the input signal. You can install these Input modules in any slot in the main SSU-2000 shelf.

1. Log into the SSU-2000 using the procedure in [Logging In to the SSU-2000](#), on page 102.
2. Enable the modules:

ICS command:

Type `INPUT xAy-z ENABLE`, then press **Enter** where x is the shelf number, y is the slot number, and z is the port number. Repeat this command for each port and each slot.

TL1 command:

See the command in step 3, below.

3. Set the priority level for each port. Set the input Priority to a value from 0 to 10; 0 indicates that the port is Monitor-only and is never selected as a reference signal. 1 is highest priority, and 10 is lowest.

ICS command:

Type `INPUT lAy-z PRI [pri]`, then press **Enter** where y is the slot number, z is the port number, and [pri] is the priority value. Repeat this command for each port and each slot.

TL1 commands:

`SET-PRMTR-INPUT::S1Ay[-z]:123::ON,[pri];`
where y is the slot number and z is the port number. This command sets the Priority to the value (1–10) you enter. Repeat this command for each port and slot.

`SET-PRMTR-CCINP::S1Ay[-z]:123::ON,[pri];`
for Composite Clock Input modules, This command enables the module (y) and port (z) and sets its Priority to the value (1–10) you enter. Repeat this command for each CC Input port and slot.

4. Disable all slots and/or ports with no connected input signal to prevent spurious alarms.

ICS command:

Type `INPUT lAy-z DISABLE` then press **Enter**, where y is the slot number and z is the port number. Repeat this command for each unused slot and port.

TL1 command:

`SET-PRMTR-INPUT::S1Ay[-z]:123::OFF;`
where y is the slot number and z is the port number. Repeat this command for each unused slot and port.

5. Set the framing type for each input port. Provision DS1 signals to either ESF or D4; provision E1 signals to CAS or CCS.

ICS command:

Type `INPUT 1Ay-z FRAME ESF|D4`, then press **Enter** where y is the slot number and z is the port number. Select either ESF or D4 as appropriate. Repeat this command as needed for each slot and port.

TL1 command:

See Step 8, below.

6. Provision the Zero Suppress for each input port to On or Off as appropriate.

ICS command:

Type `INPUT 1Ay-z ZS ON|OFF` then press **Enter** where y is the slot number and z is the port number.

TL1 command:

See Step 8, below.

7. Provision the Cyclic Redundancy Check (CRC) for each input port to On or Off.

ICS command:

Type `INPUT 1Ay-z CRC ON|OFF` then press **Enter** where y is the slot number and z is the port number.

TL1 command:

See Step 8, below.

8. Provision the Synchronization Status Message (SSM) for each input port to On or Off. When set to On, the SSU-2000 reads and interprets the SQL on the reference. If the reference does not include an SSM, the SQL is defined as STU.

ICS command:

Type `INPUT 1Ay-z SSM ON|OFF` then press **Enter**, where y is the slot number and z is the port number.

For E1 signals, you must define the bit position:

Type `INPUT 1Ay-z SSM [4-8]` then press **Enter**.

TL1 commands:

```
SET-PRMTR-INPUT::S1Ay[-z]:123::,,ESF|D4|CCS|CAS|1|1.544|2.048|5|10,ssm,zs,crc,,bit;
```

where y is the slot number and z is the port number; the numbers indicate the input frequency in megaHertz; ssm, zs, and crc are ON or OFF, as appropriate. Bit indicates the position (4–8) of the SSM in E1 signals.

9. Provision the MTIE limits for each input port according to ANSI (PRS or DS1) or ITU (G.811 or G.823) specifications.

ICS command:

Type `INPUT 1Ay-z MTIE PRS|DS1|G.811|G.823` then press **Enter**
where y is the slot number and z is the port number.

TL1 command:

```
SET-PRMTR-MTIE::S1Ay[-z]:123::{EL1|EL2|CL1|CL2},{t10},{t100},  
[t1k],[t10k],[t100k];
```

where y is the slot number and z is the port number; EL1 and EL2 are the elevation thresholds, CL1 and CL2 are the clear thresholds, and t10 through t100k are the error limits in nanoseconds.

10. Assign a name, if desired, to each input port. You can assign a name of up to 20 characters.

ICS command:

Type `IONAME 1Ay-z [name]` then press **Enter**
where y is the slot number and z is the port number.

TL1 command:

```
SET-NAME::SxAy[-z]:123:name;
```

Provisioning Output Modules

This section describes how to enable and provision Output modules, such as DS1, E1, or Composite Clock. You must enable and provision each output port as appropriate. You can install Output modules in any slot in the main SSU-2000 shelf and in the SDU-2000 Expansion Shelf.

1. Log into the SSU-2000 using the procedure in [Logging In to the SSU-2000](#), on page 102.
2. Enable the modules.

ICS command:

Type `OUTPUT xAy-z ENABLE`, then press **Enter**
where x is the shelf number, y is the slot number and z is the port number.
Repeat this command for each slot and port.

TL1 command:

```
SET-PRMTR-OUTPUT::SxA[y[-z]]:123::ON;
```

where x is the shelf number, y is the slot number, and z is the port number.
Repeat this command for each shelf, port, and slot.

3. Provision the output module as appropriate.

ICS command:

Refer to the OUTPUT command described in the *SSU-2000 Technical Reference* for details on all command options.

TL1 command:

Refer to the SET-PRMTR-OUT commands for the various Output modules in the *SSU-2000 Technical Reference*.

4. Disable unused output ports to prevent spurious alarms. Repeat this command for each unused port and slot.

ICS command:

Type `OUTPUT xAy-z DISABLE`, then press **Enter**
where x is the shelf number, y is the slot number, and z is the port number.

TL1 command:

`SET-PRMTR-OUTPUT::SxAy[-z]:123::OFF;`
where x is the shelf number, y is the slot number, and z is the port number.

5. If a DS1 input signal is not available, bypass the Clock C source for all output modules.

ICS command:

Type `OUTPUT BYPASS OFF`, then press **Enter**.

TL1 command:

`SET-PRMTR-OUTPUT::SxAy[-z]:123::,,OFF;`
where x is the shelf number, y is the slot number, and z is the port number.
Repeat this command for each shelf and Output module.

Saving the Provisioning Setup

After you provision each module, you can save the setup in the Communications module memory.

ICS command:

Type `SET SAVE`, then press **Enter**.

TL1 command:

`SET-PRMTR-SETUP::ALL:123::SAVE;`

Checking Alarm Status

All alarm indication lights should be extinguished and the POWER indication lights should be green after completing the power up sequence. The valid input reference alarm clears, rubidium lock clears, frequency alarms clear, and the ACQUIRE LED is ON. Use the following procedure with the STATUS and ALARM commands to verify that the unit is operational.

1. Log into the SSU-2000 using the procedure in [Logging In to the SSU-2000](#), on page 102.

2. Verify that there are no active alarms:

ICS command:

Type `alarm` and press **Enter**

TL1 command:

`RTRV-ALM: :ALL;`

3. Log off the SSU-2000 when you're finished.

Factory Default (Basic) Configuration

The SSU-2000 is shipped from the factory with all required operational software. The factory default (basic) configuration often does not require further configuration. Refer to the *SSU-2000 Technical Reference* for a list of the factory default settings and the default Priority Quality Level (PQL) values.

Changing Factory Defaults

Use the following steps to change the factory default or any configuration settings in the SSU-2000. This example changes an alarm from minor to major.

1. Log into the SSU-2000 using the procedure in [Logging In to the SSU-2000](#), on page 102.

2. Set the alarm levels:

ICS command:

Type `alarm 1A2 03 MAJOR` and press **Enter**. See Chapter 6 in the *SSU-2000 Technical Reference* for a list of alarm numbers for each module.

TL1 command:

`SET-PRMTR-ALARM: :S1A2:123:3,MAJ;`

3. Type `bye` and press **Enter** to log off the system.

Restoring Factory Defaults

Use the following procedure to reset the configuration to the factory default.

1. Log into the SSU-2000 using the procedure in [Logging In to the SSU-2000](#), on page 102.
2. Restore the configuration to the factory default values:

ICS command:

Type `setup xAy factory` and press **Enter**.

TL1 command:

```
SET-PRMTR-SETUP::SxA[y[-z]]:123::FACTORY;
```

3. Log off the SSU-2000 when you're finished.

Customizing Other Configuration Options

The SSU-2000 allows you to change any or all configuration settings. Use the following procedures to customize the system for a particular environment.

1. Log into the SSU-2000 using the procedure in [Logging In to the SSU-2000](#), on page 102.
2. Use the ICS or TL1 commands listed in the *SSU-2000 Technical Reference* to configure the system.



Recommendation: Do not perform any command whose function you do not understand. This could result in improper provisioning of the network.

3. Save the current configuration as the user default setting:

ICS command:

Type `setup save` and press **Enter**.

TL1 command:

```
SET-PRMTR-SETUP:::123::SAVE;
```

4. Log off the SSU-2000 when you're finished.

Backing Up and Restoring Configurations

Two new commands allow you to store a configuration file for the SSU-2000 to a TFTP (Trivial File Transfer Protocol) server. This file contains configuration data only, and not the system's firmware. The file is transferred and stored in binary format to prevent corruption of the file during transfer. The TFTP port is 69.



Note: The backup file does not include the configured IP address and serial port baud rate. This prevents the connection from possibly crashing when restoring the data.

Backing Up the Configuration

This section describes how to back up the configuration files in the SSU-2000 using ICS and TL1 commands.

Using ICS Commands

1. Connect a computer to an ICS port on the SSU-2000 and log in using an Administrator-level user name and password, as described in [Logging In to the SSU-2000](#), on page 102.
2. Type `config backup ipaddr [filename]` and press **Enter**, where `ipaddr` is the IP address of the TFTP server and `filename` is an optional file path and name for the backup file. If you do not enter the `filename` parameter, the default file `SSUCONFIG` is stored in the root directory of the TFTP server.

An example command is:

```
config backup tftp://192.92.78.179/Symmetricon/backup/ssu2000e_July11_2006.bin
```

Using TL1 Commands

1. Connect a computer to port 2000 on the SSU-2000 and log in using an Administrator-level user name and password, as described in [Logging In to the SSU-2000](#), on page 102.
2. Type `CPY-MEM:::123::, [tomem], todev;` where `tomem` is the file path and file name you wish to use for the configuration file, and `todev` is the IP address of the TFTP server. If you leave the `tomem` parameter empty, the default file `SSUCONFIG` is stored in the root directory of the TFTP server. The system responds with text similar to the following:

```
"\"172.16.20.246, SSUCONFIG\""  
"\"CONFIGURATION BACKUP, PLEASE WAIT\""  
"\"1A01 SIZE= 624\""  
"\"1A02 SIZE=5272\""  
"\"1A06 SIZE=3072\""  
"\"1A08 SIZE=1200\""  
"\"1A10 SIZE=1224\""  
"\"1A12 SIZE= 624\""  
"\"CONFIG IMAGE CREATED, SIZE=13788\""
```

```
SSU_2000 05-10-31 20:11:43
M 100 COMPLD
;
```

Restoring the Configuration

This section describes how to restore the configuration files in the SSU-2000 using ICS and TL1 commands.

Using ICS Commands

1. Connect a computer to an ICS port on the SSU-2000 and log in using an Administrator-level user name and password, as described in [Logging In to the SSU-2000](#), on page 102.
2. Type `config restore ipaddr filename` and press **Enter**, where `ipaddr` is the IP address of the TFTP server that contains the backed-up file and `filename` is the name of the file.

An example command is:

```
config restore tftp://192.92.78.179/Symmetricon/backup/ssu2000e_July11_2006.bin
```

Using TL1 Commands

1. Connect a computer to port 2000 on the SSU-2000 and log in using an Administrator-level user name and password, as described in [Logging In to the SSU-2000](#), on page 102.
2. Type `CPY-MEM:::123::frommem,fromdev,,;` where `frommem` is the filename of the configuration file and `fromdev` is the IP address of the TFTP server. The system responds with text similar to the following:

```
"\172.16.20.246, SSUCONFIG\"
  "\CONFIGURATION RESTORE, PLEASE WAIT\"
  "\1A01 DATA IS SAME AS STORED\"
  "\1A02 SIZE=5272, PASS\"
  "\1A06 SIZE=3072, PASS\"
  "\1A08 SIZE=1224, PASS\"
  "\1A10 SIZE=1224, FAIL\"
  "\1A12 DATA IS SAME AS STORED\"

SSU_2000 05-10-31 20:12:26
M 100 COMPLD
;
```

Chapter 4 Commissioning

This chapter includes the commissioning tests for the SSU-2000, which are checklist-based operational tests that field engineers perform at the installation site after completion of installation, system turn-up, and provisioning to verify that the system is correctly installed, configured and operating properly. At this point, the system is ready to be placed in service.

Record the results on the data sheet provided in the [Commissioning Test Data Sheet](#), on page 124.

In This Chapter

- [Readiness to Test Checklist](#)
- [SSU-2000 Commands](#)
- [Equipment Requirements](#)
- [Commissioning Tests](#)
- [Commissioning Test Data Sheet](#)

Readiness to Test Checklist

Before performing the commissioning tests in this section, ensure that all items in the Readiness Checklist (Table 4-1) have been performed.

Table 4-1. SSU-2000 Readiness Checklist

Step	Task	Checked
1	The SSU-2000 is installed in the rack with a minimum of 3 inches (7.6 cm) of clearance between the bottom of the lowest chassis and the floor or other equipment. An I/O Adapter panel can be installed adjacent to the bottom of the chassis without restricting the necessary cooling airflow.	
2	The SSU-2000 main chassis has a minimum of 1 inch of clearance between the top of the chassis and an adjacent chassis (except that an SSU-2000 I/O Adapter panel can be installed adjacent to the chassis with no clearance since it does not impact airflow).	
3	A Clock Module is installed in slot A1 and A12 as required (Stratum 2E must be in slot A1, if used).	
4	A Communications module is installed in slot A2.	
5	At least one Input module is installed in the chassis.	
6	An Input I/O Adapter panel is installed above the SSU-2000 and cabled to the corresponding I/O connector on the rear panel of the SSU-2000.	
7	If using the optional GPS Input module, it is installed in slot A3 or A5 and a Radio antenna is attached to the corresponding Radio antenna connector on the rear panel of the shelf.	
8	At least one Output module is installed in chassis slot A4 through A10 (unless the monitor-only configuration is being used)	
9	One Output I/O adapter panel is installed near the SSU-2000 main chassis for <i>each</i> Output module (or redundant pair) in the main chassis.	
10	One Output I/O adapter panel is installed adjacent to an SDU-2000 Expansion shelf for each output module (or redundant pair) installed in an optional SDU-2000 Expansion shelf.	
11	An SDU Termination Plug is installed on the SDU Connector (if the optional SDU-2000 Expansion shelf is not installed)	
12	–48 VDC inputs from external power supplies are connected to the A and B Power terminal strips on the rear panel of the SSU-2000 shelf.	
13	The selected set of critical, major and minor alarms terminals on the rear panel of the SSU-2000 are connected to the customer's alarm circuitry.	
14	At least one reference input is connected to each input module in the SSU-2000 main chassis.	
15	Two fuses are installed in the SSU-2000 main chassis.	

Table 4-1. SSU-2000 Readiness Checklist (Continued)

Step	Task	Checked
16	Turnup has been performed on the SSU-2000 system, user configuration setup and saved and IPs assigned for the Ethernet interface.	
17	A System Administrator and user access levels have been assigned to the SSU-2000 (see Chapter 4, Operating and Provisioning Procedures).	
18	If the Ethernet connection is being used, the ethernet connection on the rear panel of the SSU-2000 is connected into the local area network.	

SSU-2000 Commands

Several SSU-2000 commands may be useful while performing the following tests. These include:

- CONFIG – reports the modules installed in the system with part numbers and other information
- SETUP – reports current settings for the module options
- STATUS – reports the current operating status of all modules in the system

Each of these commands can also be used with a module ID# (slot position) to obtain additional detail for a module. The CLK, INPUT, and OUTPUT commands provide status for only the indicated type modules, and can also be used with the module ID# to obtain detailed information.

Equipment Requirements

The following equipment is required to perform the commissioning tests:

- Digital Voltmeter (DVM)
- Communications analyzer to check for correct framing, Sync Status Messaging (SSM), and line coding.
- Oscilloscope with correct load terminations and cables to verify outputs.



Note: If the Communications analyzer has the ability to test the pulse mask, an oscilloscope is not required.

- PC or laptop with serial port and TCP/IP connectivity and terminal emulation software such as Microsoft HyperTerminal or ASCII terminal.
- If testing stability and accuracy of output against another primary reference source (PRS), a phase recorder will also be required.

Commissioning Tests

The following paragraphs contain the SSU-2000 commissioning test procedures. These procedures consist of the following tests:

- Testing the Ethernet Communications Interface
- Testing the RS-232 Ports
- Testing the SSU-2000 Minor alarms
- Testing the SSU-2000 Major alarms
- Testing the SSU-2000 Critical alarms
- Testing the Reference Input Signals
- Testing the SSU-2000 Output signals

Testing the Ethernet Communications Interface

If an Ethernet connection to a network has been installed, use the following procedure to test the connection.

1. Telnet from the PC to the IP address assigned to the SSU-2000. The system prompts for a user name.
2. Type your assigned username and password and press **Enter**. The system prompt appears.
3. Type `bye` and press **Enter** to log off the system.

Testing the EIA-232 Ports

To test the EIA-232 port A:

1. Connect the PC or terminal to EIA-232 Port A as described in [Establishing a Connection With the SSU-2000](#), on page 90.
2. Type `HELP` and press **Enter**.
3. Verify a response to the command entered.
4. Exit the serial communication session. Move the direct connect cable to each of the remaining two serial ports and repeat steps 2 and 3.

Testing The MINOR Alarms

To test the MINOR alarm relay closures and software:

1. Set the Power A alarm level to MINOR:

ICS format: ALARM 1A02 MINOR

TL1 format: SET-PRMTR-ALARM::S1A2:::02,MINOR;

2. Remove Power A input by removing the A-bus fuse (or the fuse that supplies Power A).
3. Verify that the MINOR alarm indicator is ON.
4. Verify that the MINOR alarm is reported to the communications terminal.
5. Verify that a MINOR alarm was logged in the event log:

ICS format: EVENT ALARM

TL1 format: RTRV-EVENT::S1A2;

6. Replace the fuse to restore Power A to the unit.
7. Verify that the alarm clears, is reported and logged.

Testing the MAJOR Alarms

To test the MAJOR alarm relay closures and software:

1. Set the Power A alarm level to MAJOR:

ICS format: ALARM 1A02 MAJOR

TL1 format: SET-PRMTR-ALARM::S1A2:::02,MAJOR;

2. Remove Power A input by removing the A-bus fuse (or the fuse that supplies Power A).
3. Verify that the MAJOR alarm indicator is ON.
4. Verify that the MAJOR alarm is reported to the communications terminal.
5. Verify that a MAJOR alarm was logged in the event log:

ICS format: EVENT ALARM

TL1 format: RTRV-EVENT::S1A2;

6. Replace the fuse to restore Power A to the unit.
7. Verify that the alarm clears, is reported and logged.

Testing the CRITICAL Alarms

To test the CRITICAL alarm relay closures and software:

1. Set the Power A alarm level to CRITICAL:

ICS format: ALARM 1A02 CRITICAL

TL1 format: SET-PRMTR-ALARM::S1A2:::02,CRITICAL;

2. Remove Power A input by removing the A-bus fuse (or the fuse that supplies Power A).
3. Verify that the CRITICAL alarm indicator is ON.
4. Verify that the CRITICAL alarm is reported to the communications terminal.
5. Verify that a CRITICAL alarm was logged in the event log:

ICS format: EVENT ALARM

TL1 format: RTRV-EVENT::S1A2;

6. Replace the fuse to restore Power A to the unit.
7. Verify that the alarm clears, is reported and logged.
8. Type `ALARM` and press **Enter** to restore Power A to the original alarm level.

Testing the Reference Signals and Selection

To test the reference signals and selection:

1. Type `INPUT` to verify each input signal is present with no alarms. Each reference input will be listed by module position and port number, status, phase A and B readings, input PQL, signal alarms, and MTIE alarms.

The status should be **OK** and the Priority Quality Level (PQL) should indicate the received Sync Status Message (SSM) level or the provisioned value. The phase values will be dependent on the received signal. The signal alarms should be **////** (no alarms present, F indicates an alarm) and the MTIE alarms should all be **OK**.

2. Type `REF` and press **Enter** to determine the current selection of input reference signal. Disconnect this input signal and verify a Loss Of Signal (LOS) is reported for the input, and the unit selects an alternate input for the reference signal.

3. Reconnect the input signal and verify that the LOS condition is cleared and the reference input is selected according to the system configuration. This depends on the setting for Revertive Selection, Input Priorities, and Reference Selection mode.
4. Type `EVENT` and press **Enter**; verify that the alarms and events created are recorded in the event log.

Testing the Clock Section

To test the clock section:

1. Type `CLK` and press **Enter** to verify each clock is operating properly.

The system displays the clocks by module position (1A1 for Clock A and 1A12 for Clock B) and the status for each clock (SEL for the selected clock and OK for the standby clock).

2. Verify that the PLL mode for each clock is in **LOCK** at this time, and that the Tau value is at the maximum time constant set for each clock, dependent on the clock type of ST2 or ST3E.

The PQL should be the level the clock is supplying to the output modules, dependent on the reference input when in lock mode. The frequency offset depends on the clock type, and is typically less than $2E-10$ for ST2, $1E-6$ for ST3E, and less than $2E-07$ for TYPE1 clocks. This only indicates the uncorrected frequency offset of the oscillator which is being removed by the clock DDS circuitry.

The sigma value indicates the stability of the clock, which should be less than $1E-9$.

Testing the Output Section

To test the output section:

1. Type `OUTPUT` and press **Enter** to verify each output module is operating with no alarms. This will display the output modules by position with module status OK and the selected clock. The clock status will indicate the presence or absence of the four possible clocks: A, B, C (bypass), or D (expansion shelf only).
2. Verify that any outputs configured for redundant pairs are so indicated in the status report. The PQL will indicate the output SSM level for all ports and is supplied by the selected clock.
3. Verify that all output ports which are intended to be active indicate Y in the port status.

Testing the System Stability and Accuracy (Optional)

This test is only to be performed if a PRS (primary reference source) and the necessary test equipment is available. If the above tests have been passed, the system output will meet the stability and accuracy of the reference input.

1. Connect one of the system outputs and the PRS signal to the test equipment to monitor the stability and accuracy. This test should be allowed to run for 24 hours to collect sufficient data to verify the system output meets specifications.
2. Process the collected 24 hour data and verify that the frequency and stability (MTIE and TDEV) meet the specifications.

This completes the commissioning tests. The system is ready to be placed in service.

Commissioning Test Data Sheet

The following test data sheet should be completed as an indicator of operational readiness of the SSU-2000.

Table 4-2. Commissioning Test Data Sheet

Test	Pass	Fail
Ethernet communications		
EIA-232 Port A communications		
EIA-232 Port B communications		
EIA-232 Port C communications (on front of Communications module)		
MINOR Alarms		
MAJOR Alarms		
CRITICAL Alarms		
Reference Signals and Selection		
Clock Section		
Output Section		
System Stability and Accuracy (optional)		

Chapter 5 Maintenance and Troubleshooting

This chapter provides preventive and corrective maintenance procedures, equipment re-ordering/return procedures and troubleshooting procedures for the SSU-2000.

In This Chapter

- [Responding to SSU-2000 Alarms](#)
- [Preventive Maintenance](#)
- [Corrective Maintenance](#)
- [Troubleshooting](#)
- [Re-ordering Information](#)
- [Contacting Technical Support](#)

Responding to SSU-2000 Alarms

The SSU-2000 monitors various system parameters and stores this information as alarms and event messages which is extremely useful in troubleshooting the system. If an alarm occurs, follow the troubleshooting procedures in [Troubleshooting](#), on page 129, to clear the alarm.

Preventive Maintenance

The SSU-2000 requires no preventive maintenance. Care should be taken to ensure the unit is not exposed to hazards such as direct sunlight, open windows, or extreme heat. See [Electromagnetic Interference \(EMI\) Considerations](#), on page 61, for other conditions that may cause damage.

Should the unit require cleaning, the exterior chassis may be wiped off using a soft cloth dampened with mild soapy water.



Caution: To avoid damage to the unit, under no circumstances should the interior chassis of the SSU-2000 be allowed to come in contact with water.



Caution: To avoid damage to the unit, never attempt to vacuum the interior of the SSU-2000.



Caution: To avoid the possibility of the lithium battery exploding in the Communications module or Clock modules, **do not** replace the battery. Return the entire module to Symmetricom Global Services for battery replacement and disposal.



Caution: To avoid electrostatic discharge (ESD) and damage to the internal circuitry, never attempt to vacuum the interior of the SDU-2000e. If damaged, return the unit to Symmetricom Global Services for corrective service.



Caution: To avoid personal injury and electrostatic discharge (ESD) damage to equipment, follow the ESD precautions as listed in this guide.

Corrective Maintenance

The SSU-2000 and SDU-2000 have a modular design and field service is limited to replacing the FRUs (field replaceable units) identified in [Table 5-1](#) and [Table 5-2](#). These tables also outline possible component problems and corrective action. Refer to [Re-ordering Information](#), on page 135, for information on re-ordering, re-packing, or returning equipment to the factory.



Warning: To avoid serious personal injury or death, exercise caution when working near high voltage lines. In particular:

- Use extreme caution when installing the GPS antenna near, under or around high voltage lines.
 - Follow local building electrical codes for grounding the antenna system that is used with the SSU-2000.
-



Caution: For continued fire protection, fuse the interface “A” power feeds at the power distribution source for (5A --- VDC). This unit must be grounded. Refer all servicing to qualified personnel.



Caution: For continued EMC compliance, replace all deformed module gaskets with the same type. Clean gaskets and mating surfaces. Secure all modules with captive screws.



Caution: To maintain EMC compliance, use only properly shielded cabling on all telecom signal wiring, including I/O, clocks, and Ethernet connections. Ensure that connections are appropriately grounded.

Table 5-1. SSU Corrective Action Table

Component	Corrective Action	Part Number
Motherboard or Main Chassis Fault	Contact Symmetricom Global Services.	25413020-000-0
Defective Cable	Replace defective cable.	See Chapter 9, Hardware Configuration Guide
Module Fault(s)	<ul style="list-style-type: none"> a. Check that module(s) is seated correctly. b. Address any fault LED lights. c. If present, press RST button on Comms module. d. Check both Power A and Power B inputs for a tripped breaker or blown fuse on the input power control panel. e. Replace module. f. If unable to correct the problem, contact Symmetricom Global Services. 	All Modules
Module Replacement		
Communications Module 2E Clock Module 3E Clock Module Type 1 Clock Module 1-Port DS1 Input Module 3-Port DS1 Input Module 1-Port E1 Input Module 3-Port E1 Input Module GPS Input Module CC Input Module Japanese Sine Wave Input Module Japanese CC Input Module DS1 Output Module E1 Output Module CC Output Module Japanese CC Output Module Japanese Sine Wave Output Module E1/2048 kHz Output Module 2048 kHz Output Module RS 422 Output Module DS1 Dual Line Re-Timing Unit DS1 Quad Line Re-Timing Unit E1 Quad Line Re-Timing Unit	See Handling Modules , on page 81	23413012-000-0 23413016-000-0 23413015-000-0 23413015-001-0 23413013-001-0 23413013-002-0 23413014-001-0 23413014-002-0 23413017-000-0 23413279-000-0 23413305-000-0 23413307-000-0 23413017-000-0 23413018-000-0 23413158-000-0 23413306-000-0 23413304-000-0 23413292-000-0 23413159-000-0 23413287-000-0 23413301-000-0 23413301-001-0 23413309-001-0

Table 5-2. SDU Corrective Action Table

Component	Corrective Action	Part Number
Motherboard or Main Chassis Fault	Contact Symmetricom Global Services.	25413023-000-0
Defective Cable	Replace defective cable.	060-10003-10-2 (1 m cable; other lengths available)
Module Fault(s)	a. Check that module(s) is seated correctly. b. Address any fault LED lights. c. If present, press RST button on Comms module. d. Check both Power A and Power B inputs for a tripped breaker or blown fuse on the input power control panel. e. Replace module. f. If you are unable to correct the problem, contact Symmetricom Global Services.	All Modules
Module Replacement		
DS1 Output Module		23413017-000-0
E1 Output Module		23413018-000-0
CC Output Module		23413158-000-0
Japanese CC Output Module		23413306-000-0
Japanese Sine Wave Output Module		23413304-000-0
E1/2048 kHz Output Module		23413292-000-0
2048 kHz Output Module		23413159-000-0
RS 422 Output Module		23413287-000-0
DS1 Dual Line Re-Timing Unit		23413301-000-0
DS1 Quad Line Re-Timing Unit		23413301-001-0
E1 Quad Line Re-Timing Unit		23413309-001-0

Troubleshooting

The SSU-2000 incorporates many alarms and event messages to alert that a possible problem exists. These alarm and event message reports can be accessed via the Communications module serial ports using a dumb terminal or PC. Communication may also be established using the RJ-45 Ethernet connector (ETHERNET 10-BASE-T) on the connector interface panel of the chassis. [Communicating by Serial Port](#), on page 91, outlines the procedures for connecting

to the SSU-2000 using the Comms module serial ports. [Communicating by Ethernet](#), on page 92, outlines the procedures for connecting via the Ethernet connection. Chapter 6 of the *SSU-2000 Technical Reference* provides details on event and alarm descriptions, default event and alarm levels, status messages and corrective action

Establishing a Connection



Note: An SSU-2000 Administrator must be appointed prior to connecting to the system. The Administrator will assign User privileges and access codes. See [Chapter 3, Provisioning and Operating the SSU-2000](#), for more details.

To perform troubleshooting on the SSU-2000, you must establish a serial connection to a terminal, laptop or PC with terminal emulation software. This is done using port A or B (located on the rear panel), or the Local, located on the front panel of the communications module. If the SSU-2000 is connected to a LAN, an Ethernet telnet session may be established. Refer to [Communicating by Serial Port](#), on page 91, to establish a serial connection and [Communicating by Ethernet](#), on page 92 to establish an Ethernet connection.

Troubleshooting Guide

This section describes troubleshooting procedures for the SSU-2000. [Table 5-3](#) details common system faults and the corrective action to correct the problem.

The modular design of the SSU-2000 offers a high level of stability and reliability. After installation and self-diagnostics, the majority of events and alarms can be attributed to fluctuations in signal quality, which may be self-clearing. Others may be caused by faulty hardware and software configurations. Regardless of the cause, hardware seldom needs to be replaced. If corrective action has been taken and the problem persists, call Symmetricom Global Services.

When a Comms module is installed and functioning properly, it monitors the SSU-2000 and logs unit events into non-volatile memory for user inspection at a later date. Events are conditions within the unit, or at the interfaces of the unit, which may indicate abnormal operation or a change in the unit's operational status.

Although every alarm is considered to be an event, not every event is an alarm. For example, a login is recorded as an event but is not considered to be an alarm. In this case, no action is required by the user. Recurring events may be escalated to alarm status and may require action by the user. Conversely, alarms may be de-escalated and corrected automatically. [Corrective Maintenance](#), on page 127, explains how to interpret status messages and take corrective action if needed.

Interpreting Status Messages

The SSU-2000 provides two types of status messages: alarm and event. The following sections describe these messages.

Alarm Messages

With the exception of loss of power alarms (on main chassis and expansion unit) all alarms are module alarms. Chapter 6 of the *SSU-2000 Technical Reference* lists each module with corresponding alarm descriptions, alarm levels, status messages, and corrective action. Since a “no fault” alarm requires no action, the “Corrective Action” category applies only to fault messages requiring user intervention.

Event Messages

Chapter 6 of the *SSU-2000 Technical Reference* lists event messages categorized by module. Each section lists status messages associated with each module and an event description of each message.

Figure 5-1 shows the structure of a typical Alarm and Event report status messages.

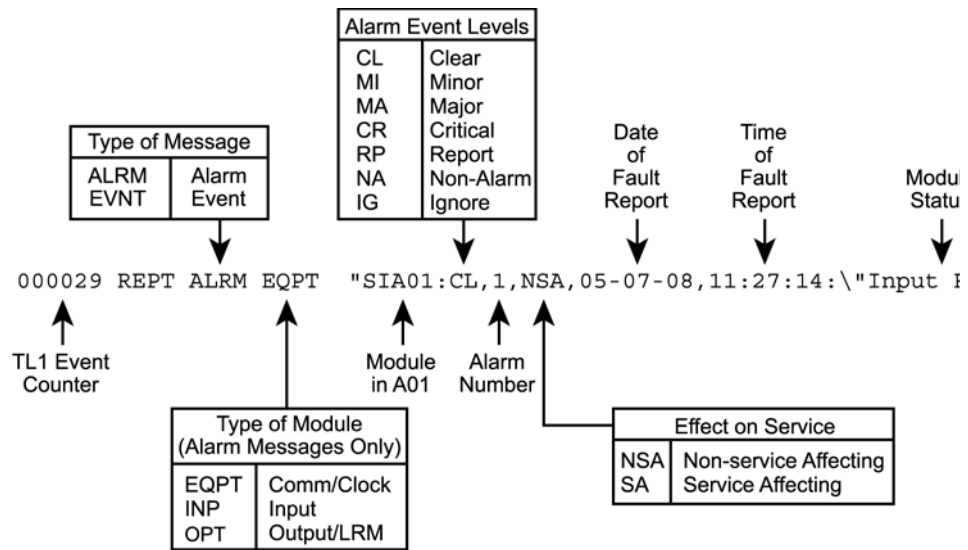

Figure 5-1. Alarm and Event Status Breakdown

Table 5-3 outlines troubleshooting procedures for the SSU-2000.

Table 5-3. SSU-2000 Troubleshooting Procedures

Symptom	Probable Cause	Troubleshooting Procedure/Corrective Action
No LED lit on any module	No power to unit	Check to ensure that UPS (if applicable) is operating correctly.
	Both A and B fuses are blown	Remove both fuses and replace.
	Loss of ground	Re-attach ground wires.
	Loose power cabling to unit	Check that power cables to unit are securely fastened.
	Main shelf is faulty	Contact Symmetricom Global Services.
Unable to communicate with system	Loose cabling	Check that cabling is securely fastened.
	Bad peripheral device configuration	Check that communication device is properly configured (refer to Establishing a Connection , on page 130, for more information).
	Improperly installed or faulty Comms module	Re-seat the Comms module. Press the RST button located on the front panel of module. If problem is not rectified, call Symmetricom Global Services.
	Software emulator is configured to Com1, but cable is physically attached to Com2	Either attach cable to Com1 or re-configure software emulator to Com2.
	Software emulator is set to 9600 baud, but system baud rate is 19,200.	Change to the software emulator to 19 200 baud.
	Bad serial port(s)	Connect to another serial port. If none of the ports are functional, call Symmetricom Global Services.
Status LED on Input module is amber	Firmware compromised	Re-seat the Input module. If problem is not rectified, call Symmetricom Global Services.

Table 5-3. SSU-2000 Troubleshooting Procedures (Continued)

Symptom	Probable Cause	Troubleshooting Procedure/Corrective Action
Fault LED on Output module is lit	Loose module	Reseat module.
	Loss of signal to output module	Reseat or replace input module (or clock module if necessary).
	Line fault	Remove the Tx Cable
	Improper redundancy configuration	Adjust accordingly. Main shelf: <ul style="list-style-type: none"> ■ left slot = even ■ right slot = odd Expansion shelf: <ul style="list-style-type: none"> ■ left slot = odd ■ right slot = even
Fault LED on Output module is flashing amber	Fault on distribution cabling	Verify cabling is connected properly. Replace cabling.
No LED lit on modules	Power supply failure	Check connection to power supply.
	Blown fuse	Replace module.
No alarms being reported when there is an alarmed condition	Compromised firmware	Press RST on Comms module front panel.
	Faulty Comms module	Replace Comms module.
	Alarmed module is faulty	Replace module.
Loss of power from Expansion shelf	No power to unit	Check to ensure that UPS (if applicable) is operating correctly.
	Both A and B fuses on Expansion shelf are blown	Remove fuses and replace.
	Loss of ground	Re-attach ground wires.
	Loose power cabling to Expansion shelf	Check that power cables to unit are securely fastened.
	Expansion shelf is faulty	Call Symmetricom Global Services.
Loss of signal from Expansion shelf	D clock not connected; loose SDU cable to the expansion shelf	Check SDU cable and connect D clock.
Any amber source LED on the Output module	Loss of clock signal	Ensure clock modules are inserted properly.
	Clock modules are in warmup mode	No action necessary.

Table 5-3. SSU-2000 Troubleshooting Procedures (Continued)

Symptom	Probable Cause	Troubleshooting Procedure/Corrective Action
Any amber LED on Input module	No signal to the input panel	Ensure signals are properly routed to the input panel.
	No input signal on cable connected to I/O adapter panel.	Replace <i>no-signal</i> cable with signaled cable.
	I/O adapter panel is not connected to the Input module.	Connect the I/O adapter panel to the Input module.
No output signal on the output panel	Port is not turned on.	Use the appropriate command to turn the port on.
	The I/O adapter panel is not connected to the Output module.	Connect the I/O adapter panel to the Output module.

Troubleshooting the SDU-2000

The Buffer module in the SDU-2000 collects status information from the Output modules and relays status messages to the SSU-2000. The status messages alert the SSU-2000 when a possible problem exists; they can be accessed through the SSU-2000 using a terminal or PC using a terminal emulation software. Refer to [Establishing a Connection With the SSU-2000](#), on page 90, for more information on connecting to an SSU-2000 for troubleshooting. Table 5-4 outlines troubleshooting procedures for the SDU-2000.



Note: If fault isolation and corrective action have been performed and the problem persists, contact Symmetricom Global Services.

Table 5-4. SDU-2000e Troubleshooting Procedures

Symptom	Probable Cause	Troubleshooting Procedure/Corrective Action
Output module Fault indicator is on	Loose module	Re-seat module.
Output module Fault indicator is flashing Amber	Fault on distribution cabling	Verify that cabling is connected properly. Replace cabling as needed.
Output module Source indicator is amber	Loss of clock signal	Ensure cabling to main chassis is secure and correctly installed.
	Clock modules in main chassis are in Warm-up mode	No action necessary.

Table 5-4. SDU-2000e Troubleshooting Procedures (Continued)

Symptom	Probable Cause	Troubleshooting Procedure/Corrective Action
Indicators on any module are not illuminated	No power to unit	Verify that there is power to BUS-A and BUS-B, and that the power inputs are providing the required –48/60 VDC to the unit.
	Loss of ground	Re-attach ground wires.
	Loose power cabling to unit	Check that power cables to unit are securely fastened.
	Expansion shelf is faulty	Contact Symmetricom Global Services.
Loss of signal to/from expansion shelf	Loose SDU cable to the expansion shelf	Check SDU cable.
	Both clocks not connected	Connect one or both clocks.

Re-ordering Information

To re-order any module or accessory, contact the Symmetricom Sales Department. Supply the module or accessory name and its part number along with the purchase order number. A current list of SSU-2000 system components and modules/accessories and their part numbers is provided in [Table 9-3](#). Accessories are described in the *SSU-2000 Technical Reference*.

Equipment Return Procedure

You should return the equipment to Symmetricom only after you have exhausted the troubleshooting procedures described earlier in this chapter, or if Symmetricom Global Services has advised you to return the unit.



Note: Please retain the original packaging of the unit for re-shipping the product as needed. If the original packaging has been discarded, contact Symmetricom Global Services (SGS) for assistance.

Repacking the Unit

Return all units in the original packaging. If the original packaging is not available, contact Symmetricom Global Services. Use standard packing procedures for products being returned for repair to protect the equipment during shipment. Connectors should be protected with connector covers or the equipment should be wrapped in plastic before packaging. Ensure that the front and rear panels are protected when packaged.

Equipment Return Procedure

To return equipment to Symmetricom for repair:

1. Call Symmetricom Global Services (SGS) at 888-367-7966 (toll-free in USA only), 408-428-7907, or +44 (0) 1189 699 799 in Europe, Middle East, or Africa to obtain a return material authorization number (RMA) before returning the product for service. Retain this RMA number for future reference.
2. Provide a description of the problem, product item number, serial number, and warranty expiration date.
3. Provide the return shipping information (customer field contact, address, telephone number, and so forth.)
4. Ship the product to Symmetricom, transportation prepaid and insured, with the Return Material Authorization (RMA) number and item numbers or part numbers clearly marked on the outside of the container to the address given to you by Symmetricom Global Services.

Repaired equipment is returned to you with shipping costs prepaid by Symmetricom.

Contacting Technical Support

If you encounter any difficulty installing, operating, or maintaining the product, contact Symmetricom Global Services at:

Symmetricom, Inc.
2300 Orchard Parkway
San Jose, CA 95131-1017

U.S.A. Call Center:
888-367-7966 (from inside U.S.A. only – toll-free)
408-428-7907
Fax: 408-428-7998

Europe, Middle East, and Africa (EMEA) Call Center:
+44 (0) 1189 699 799
Fax: +44 (0) 1189 277 520
E-mail: support@symmetricom.com

Internet: <http://www.symmetricom.com>

Chapter 6 Clock Module Reference Data

This chapter contains reference information for the Clock and Communications modules available for use in the SSU-2000.

In This Chapter

- [Stratum 2E Clock Module](#)
- [Stratum 3E Clock Module](#)
- [Type 1 Clock Module](#)
- [Communications Module](#)

Stratum 2E Clock Module

This section provides user reference information for the Stratum 2E Clock module (part number 23413016-000-0) used in the SSU-2000.

Functional Overview

The Stratum 2E Clock module uses a Rubidium oscillator and meets or exceeds the performance requirements for ITU and ETSI Type I Transit and Type II Local Node clocks and ANSI and Telcordia Technologies (Bellcore) Stratum 2 clocks.

The Clock module reads measurement data from the Input modules, provides frequency control of the oscillators through DDS circuitry, and generates reference signals used by the input and Output modules.

A typical SSU-2000 system contains dual redundant Clock modules. Each Clock module maintains phase synchronization with the redundant Clock module. Its hardware and software also provides for temperature compensation, an initial offset adjustment, and frequency adjustment resolution of 1×10^{-13} or better.

With redundant Clock modules, one is selected as the master and the other as backup, with automatic switching on module removal or failure.

The master Clock module controls the operation of the Input and Output modules and downloads module configuration information to all modules (except for the Communications module), requests measurement data and status from the Input modules, and sets the Output modules to use currently selected clock signals. The Clock modules maintain an internal time-of-day clock that is used to time stamp events to within 0.1 second of detection of the event.

This module provides an 8 kHz signal used by the Input modules and a 4 kHz signal used by the Output modules. Each Clock module provides one set of signals for use by the modules in the main chassis, and a separate set for the expansion shelves.

Functional Block Diagram

A simplified block diagram of the Stratum 2E Clock module is shown in [Figure 6-1](#).

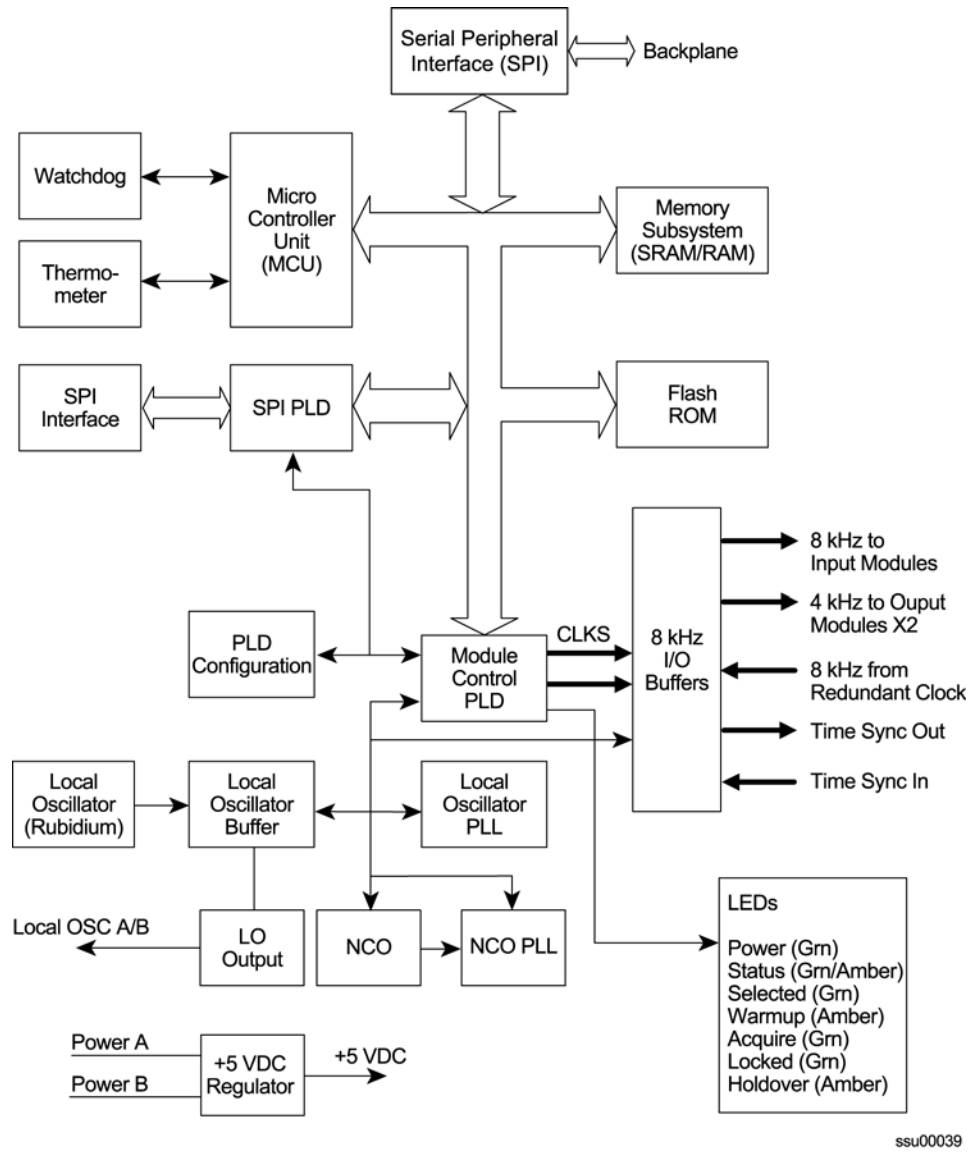

Figure 6-1. Block Diagram of the Stratum 2E Clock Module

Status LED Indicators

The status LED indicators on the Stratum 2E Clock module are illustrated in [Figure 6-2](#) and are described in [Table 6-1](#).

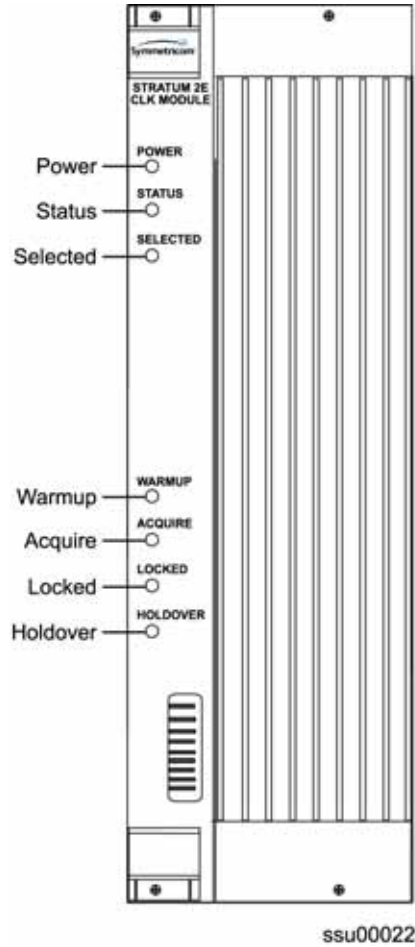

Figure 6-2. Front Panel of the Stratum 2E Clock Module

Table 6-1. Stratum 2E Clock Module Status LED Indicators

Indicator	Color	Description
Power	Green	On = The Clock module is receiving power Off = No power present
Status	Green/Amber	On (Green) = No faults detected On Amber blinking = Clock module is downloading firmware On (Amber) = Unknown Clock module status or fault detected
Selected	Green	On = Module selected for providing outputs. Off = Module not selected

Table 6-1. Stratum 2E Clock Module Status LED Indicators (Continued)

Indicator	Color	Description
Warmup	Amber	On = Clock module is in warm-up mode Off = Clock module has completed warmup
Acquire	Green	On = Clock module is acquiring a lock on a signal Off = Not acquiring a lock on a signal
Locked	Green	On = Clock module is locked on a signal Off = Clock module is not locked on a signal
Holdover	Amber	On = Clock module is in Holdover mode of operation Off = Clock module is not in Holdover mode

Functional Specifications

Table 6-2 lists the specifications for the Stratum 2E Clock module.

Table 6-2. Stratum 2E Clock Module Specifications

Performance Characteristic	Specification
Free Running Accuracy	Within $\pm 5 \times 10^{-10}$ the first year Within $\pm 5 \times 10^{-9}$ after 10 years
Holdover Stability (Rubidium LO) 0 to 24 hrs, @ +10 to +50°C 0 to 24 hrs, @ 0 to +50°C 30 days @ +10 to +40°C 30 days @ 0 to +50°C	$\pm 9 \times 10^{-11}$ $\pm 1 \times 10^{-10}$ $\pm 1.5 \times 10^{-10}$ $\pm 1.7 \times 10^{-10}$
Numeric Controlled Oscillator (NCO) PLL lock range	$\pm 5 \times 10^{-4}$
Tuning Resolution (Locked Mode)	$< 1 \times 10^{-13}$
Warm-up Time (Warm-up Mode)	20 minutes
Wander Output (Holdover)	Includes effects of all SSU-2000 modules: Compliant with clock levels per ITU-T G.812, T1.101-1999, and Telcordia Technologies GR-378-CORE and GR-1244-CORE. Meets SONET requirements per T1.105. Meets or exceeds performance requirements for ITU-T G.812 Type II and ETSI Transit Node clocks and T1.101 and Telcordia Technologies (Bellcore) Stratum 2 clocks.
Jitter (Locked or Holdover)	< 4 ns p-p (measured at the CLKA/BIN 8kHz output)
Starting Time Constant (min tau)	300 to 10 000
Final Time Constant (max tau)	1000 to 9000

Stratum 3E Clock Module

This section provides user reference information for the Stratum 3E Clock module (part number 23413015-000-0) used in the SSU-2000. This module provides a lower cost backup clock solution for the system.

Functional Overview

The Stratum 3E Clock module meets or exceeds the performance requirements for ITU and ETSI Type III Local Node clocks and ANSI and Telcordia Technologies (Bellcore) Stratum 3E clocks.

The Stratum 3E Clock module receives measurement data from the Input modules, provides frequency control of the outputs through DDS circuitry, and generates a reference signal for use by the Input and Output modules. The Stratum 3E Clock module communicates with the Communications module and the Stratum 2E Clock module to maintain phase synchronization with the redundant Clock module. The Stratum 3E Clock module's hardware and software provides for temperature compensation, aging compensation for the Quartz oscillator, an initial offset adjustment, and frequency adjustment resolution of 1×10^{-13} or better.

When serving as the master clock, the Stratum 3E Clock module controls the operation of the Input and Output modules and downloads module configuration information to all modules, requests measurement data and status from the Input modules, and sets the Output modules to use currently selected Clock signals. The Stratum 3E Clock module also contains a battery powered clock that maintains the clock for timestamping events. The Clock module software reads the clock on startup and sets the clock when the system time is changed. The timestamp is referenced as the number of seconds since 00:00:00 January 1, 1980.

Functional Block Diagram

A simplified block diagram of the Stratum 3E Clock module is provided in [Figure 6-3](#).

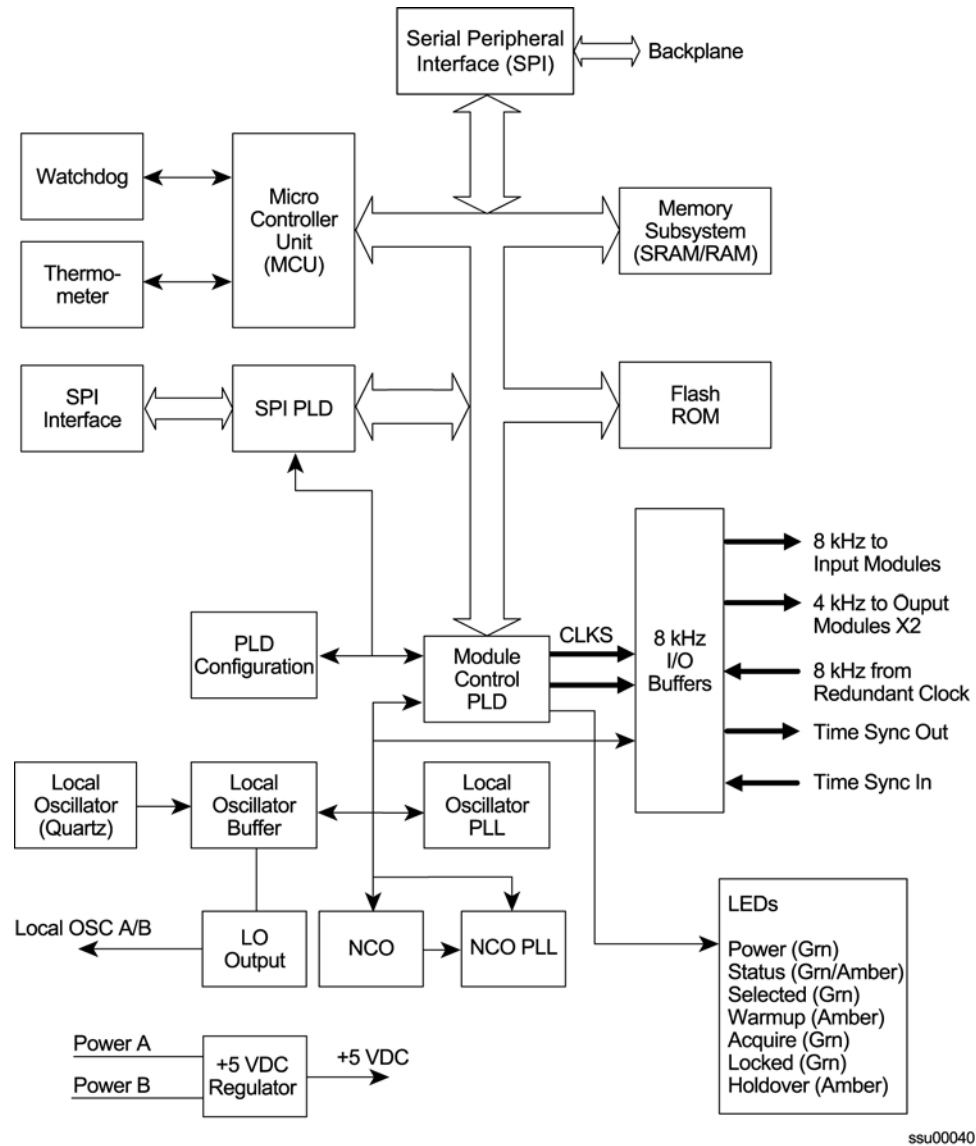

Figure 6-3. Block Diagram of the Stratum 3E Clock Module

Status LED Indicators

The status LED indicators on the Stratum 3E Clock module are illustrated in [Figure 6-4](#) and listed and are described in [Table 6-3](#).

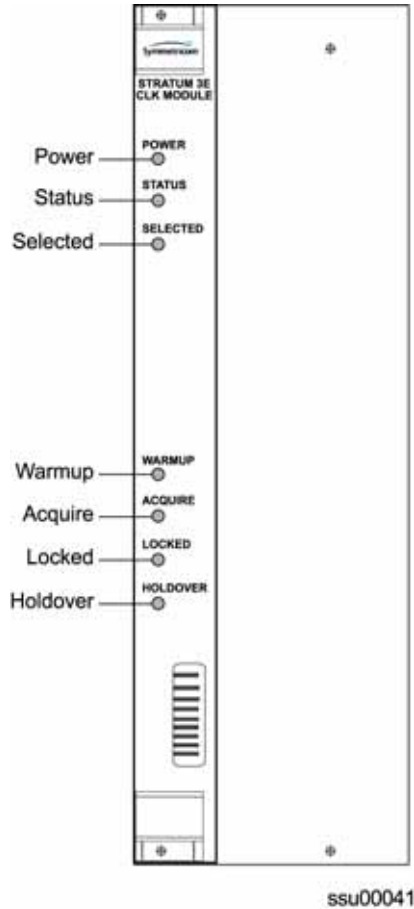

Figure 6-4. Front Panel of the Stratum 3E Clock Module

Table 6-3. Stratum 3E Clock Module Status LED Indicators

Indicator	Color	Description
POWER	Green	On = The Clock module is receiving power Off = No power present
STATUS	Green/Amber	On (Green) = No faults detected On (Amber) blinking = Clock module is downloading firmware On (Amber) = Unknown Clock module status or fault detected
SELECTED	Green	On = Module selected for providing outputs Off = Module not selected
WARMUP	Amber	On = Clock module is in warm-up mode Off = Clock module has completed warmup

Table 6-3. Stratum 3E Clock Module Status LED Indicators (Continued)

Indicator	Color	Description
ACQUIRE	Green	On = Clock module is acquiring a lock on a signal Off = Not acquiring a lock on a signal
LOCKED	Green	On= Clock module is locked on a signal Off = Clock module is not locked on a signal
HOLDOVER	Amber	On = Clock module is in holdover mode of operation Off = Clock module is not in holdover mode

Performance Specifications

Specifications for the Stratum 3E Clock module are provided in [Table 6-4](#).

Table 6-4. Stratum 3E Clock Module Performance Specifications

Performance Characteristic	Specification
Free Running Accuracy	Within $\pm 2.5 \times 10^{-7}$, the first year (vendor spec) Within $\pm 3.7 \times 10^{-6}$ after 20 years (vendor spec)
Holdover Stability 0 to 24 hrs, @ +10 to +50°C 0 to 24 hrs, @ 0 to +50°C	$\pm 5 \times 10^{-9}$ $\pm 1 \times 10^{-8}$
Numeric Controlled Oscillator (NCO) PLL lock range	$\pm 5 \times 10^{-4}$
Tuning Resolution (Locked Mode)	$< 1 \times 10^{-13}$
Warm-up Time (Warm-up Mode)	20 minutes
Wander Output (Holdover)	Includes effects of all SSU-2000 modules: Exceeds requirements of (ANSI) T1.101-1994, T1.105.09, ITU G.811, T1X1.3 (proposed new limits for wander generation), and G.823
Jitter (Locked or Holdover)	< 4 ns p-p (measured at the CLKA/BIN 8 kHz output)
Starting Time Constant (min tau)	150 to 450
Final Time Constant (max tau)	150 to 450

Type 1 Clock Module

This section provides operating instructions and software provisioning procedures for the Type 1 Clock module (part number 23413015-001-0), designed for use in the SSU-2000 Synchronization Supply Unit.

Functional Overview

The Type 1 Clock module uses a quartz oscillator which meets or exceeds the performance requirements for ITU and ETSI Type 1 Slave clocks. The Clock module reads measurement data from the Input modules, provides frequency control of the oscillator through DDS circuitry, and generates reference signals used by the Input and Output modules.

A typical SSU-2000 shelf contains dual redundant Clock modules. Each Clock module maintains phase synchronization with the redundant Clock module. Its hardware and software also provides an initial offset adjustment and frequency adjustment resolution of 1×10^{-13} or better.

With redundant Clock modules, one is selected as the master and the other as backup, with automatic switching on module removal or failure.

The master Clock module controls the operation of the Input and Output modules and downloads module configuration information to all modules (except for the Communications module), requests measurement data and status from the Input modules, and sets the Output modules to use currently selected clock signals, and provides the system Priority Quality Level (PQL) to all Output modules configured to generate Synchronization Status Messages (SSMs). The Clock modules maintain an internal time-of-day clock that is used to time stamp events to within 0.1 second of detection of the event.

This module provides an 8 kHz signal used by the Input modules and a 4 kHz signal used by the Output modules. Each Clock module provides one set of signals for use by the modules in the main chassis, and a separate set for the expansion shelves.

Functional Block Diagram

A simplified block diagram of the Type 1 Clock module is shown in [Figure 6-5](#).

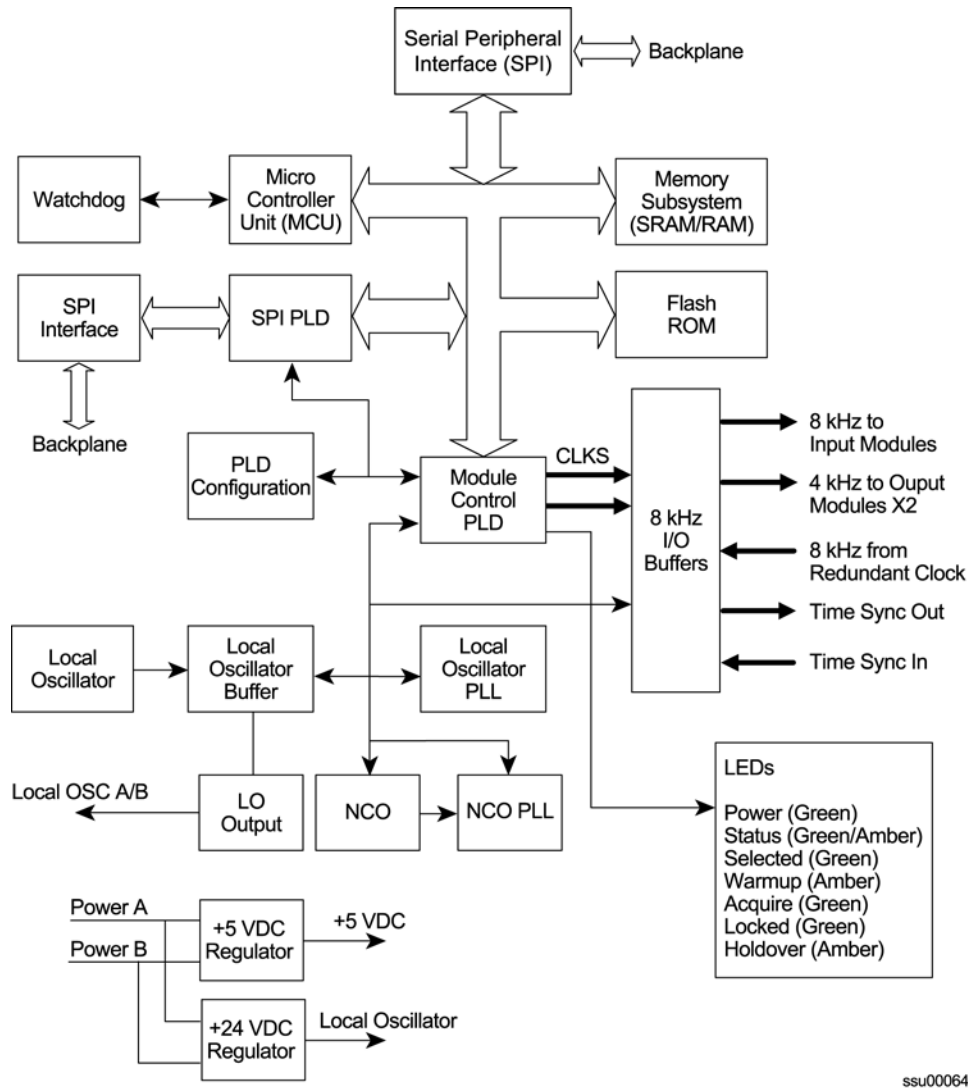

ssu00064

Figure 6-5. Block Diagram of the Type 1 Clock Module

Status LED Indicators

The status LED indicators on the Type 1 Clock module are illustrated in [Figure 6-6](#) and are described in [Table 6-5](#).

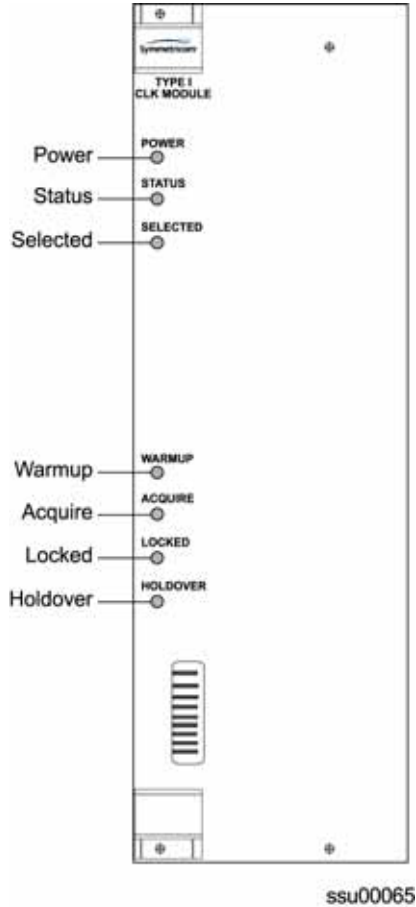

Figure 6-6. Front Panel of the Type 1 Clock Module

Table 6-5. Type 1 Clock Module Status LED Indicators

Indicator	Color	Description
Power	Green	On = The Clock module is receiving power Off = No power present
Status	Green/Amber	On (Green) = No faults detected On Amber blinking = Clock module is downloading firmware On (Amber) = Unknown Clock module status or fault detected
Selected	Green	On = Module selected for providing clock signals for output generation. Off = Module not selected
Warmup	Amber	On = Clock module is in warm-up mode Off = Clock module has completed warmup

Table 6-5. Type 1 Clock Module Status LED Indicators (Continued)

Indicator	Color	Description
Acquire	Green	On = Clock module is acquiring a lock on a signal Off = Not acquiring a lock on a signal
Locked	Green	On = Clock module is locked on a signal Off = Clock module is not locked on a signal
Holdover	Amber	On = Clock module is in Holdover mode of operation Off = Clock module is not in Holdover mode

Functional Specifications

Table 6-6 lists the specifications for the Type 1 Clock module.

Table 6-6. Type 1 Clock Module Specifications

Performance Characteristic	Specification
Holdover Stability 0 to 24 hrs @ -5 to +45°C	$\pm 2 \times 10^{-9}$ (after 30 days operation)
Numeric Controlled Oscillator (NCO) PLL lock range	$\pm 5 \times 10^{-4}$
Tuning Resolution (Locked Mode)	$< 1 \times 10^{-13}$
Warm-up Time (Warm-up Mode)	20 minutes
Wander Output (Holdover)	Includes effects of all SSU-2000 modules: Compliant with clock levels per ITU-T G.812, Type 1 and ETSI EN300 462-4
Jitter (Locked or Holdover)	< 4 ns p-p (measured at the CLKA/BIN 8 kHz output)

Communications Module

This section provides reference information on the Communications module (part number 23413012-000-0) that functions as a master controller for the SSU-2000.

Functional Overview

The Communications module installs in slot A2 and provides an interface between the user and the SSU-2000. This interface allows users to display and control much of the activity in the SSU-2000 shelf and the optional SDU-2000 expansion shelf. The Communications module supports three serial ports (including one local craft port) and one Ethernet port, and allows communication over each of them independently in one of several possible modes (ASCII mode, TL1 mode, and packet mode).

The software in the Communications module allows for reprogramming of its flash ROM and for reconfiguring of all programmable logic devices, while installed at the user's location. The Communications module also allows for this same capability for all other modules installed in the SSU-2000 shelf by downloading it through the Communications module.

When the Communications module is installed, it performs an initial software verification test to verify operation. If the module is installed in the SSU-2000 with power already applied and with other modules installed, the Communications module reads the configuration of the modules in the main shelf and in all installed expansion shelves. This information is saved in nonvolatile memory on the Communications module. If power is applied to the SSU-2000 after the Communications module is installed, it initializes before any other module and provides configuration information to the individual modules.

The master controller function for the SSU-2000 can reside in the Communications module or in either of the Clock modules. The priority of the selection of the module that will provide the master controller function is the Communications module, Clock A, and Clock B, in that order. In the event of removal of the module designated as the master controller, that function automatically and seamlessly switches to the next module in priority order.

All man/machine communications are controlled by the Communications module. This module then communicates with the other modules in the SSU-2000 to read configuration data, set operational parameters, and determine what type of modules are installed. When a module is replaced, the controller loads the correct operational parameters into the replacement module.

Functional Block Diagram

A simplified block diagram of the Communications module is shown in [Figure 6-7](#).

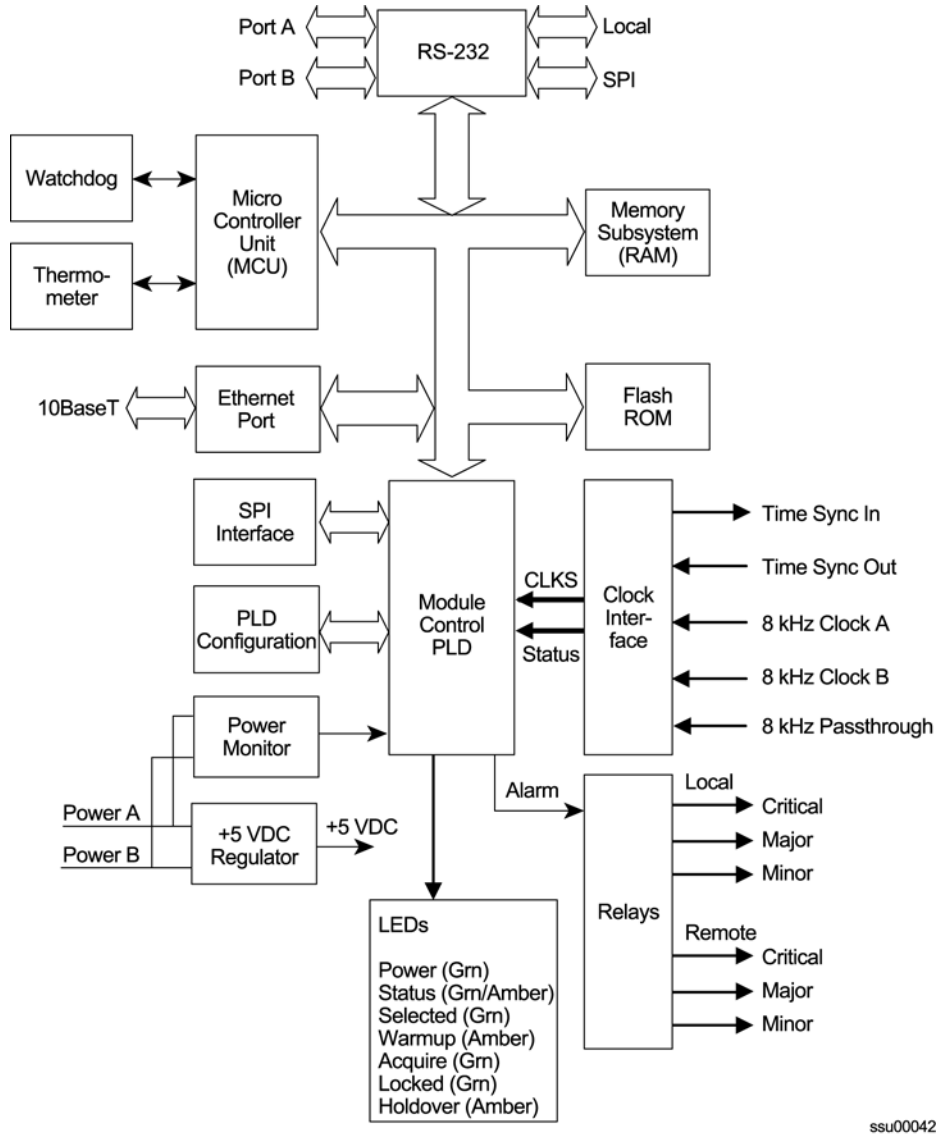

ssu00042

Figure 6-7. Block Diagram of the Communications Module

Status LED Indicators

The Communications module contains a group of eight status LED indicators that convey visual status to the user, as shown in [Figure 6-8](#) and described in [Table 6-7](#).

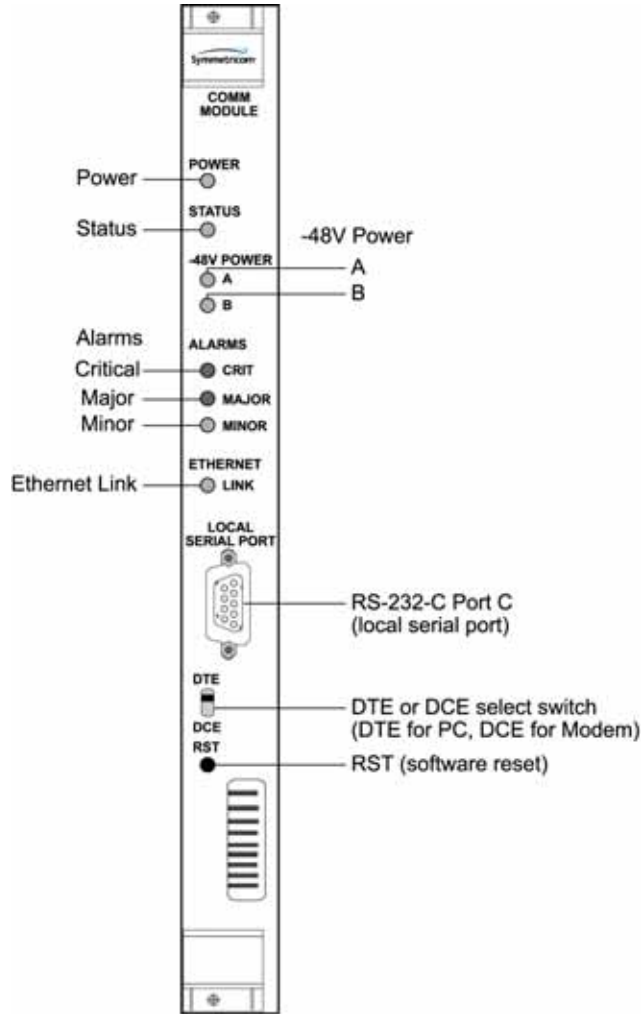

ssu00032

Figure 6-8. Front Panel of the Communications Module

Table 6-7. Communications Module Status LED Indicators

Indicator	Color	Description
Power	Green	On = The module is receiving power Off = No Power Present
Status	Green/Amber	On (Green) = No faults detected On (Amber) Blinking = Module is downloading firmware On (Amber) = Module fault detected

Table 6-7. Communications Module Status LED Indicators (Continued)

Indicator	Color	Description
-48vDC Power A and B	Green	On = Power connected Off = Power not connected
Critical Alarm	Red	On = System alarm is set to Critical Off = No critical system alarm
Major Alarm	Amber	On = Major system alarm Off = No major system alarm
Minor Alarm	Amber	On = Minor system alarm Off = No minor system alarm
Ethernet Link	Green	On = Physical Ethernet connection is made Off = No physical Ethernet connection

Communications Module Alarm Logic

Events are an indication that something has occurred within the unit. Alarms are a subset of events. All alarms are events, but not all events are alarms. All events log the following information:

- Timestamp
- Event type
- Event/alarm level
- Condition that caused the event

Communications Module Event Log

The Communications module maintains an event history of the last 500 events in non-volatile RAM that can be retrieved by the user. In the interactive mode, the Communications module always returns the events with the last generated event output last.

Using one of the available communication ports, a user can request the following:

- List of events by a given type of REPORT or ALARM
- List of events based upon a start and stop time
- Clear the event log

Interactive mode ports can request:

- Latest event logged
- A number of last events be displayed
- All information currently logged in the history buffer

Alarm Levels

The Communications module alarm logic incorporates three alarm levels:

- **CRITICAL Alarms** – This class of alarms requires immediate user intervention. When a critical alarm condition is detected, the CRITICAL ALARM relay at the rear panel of the SSU-2000 is activated and the CRITICAL ALARM LED on the front of the Communications module lights red.
- **MAJOR Alarms** – A class of alarms that may require immediate user intervention. When a major alarm condition is detected, the major alarm relay on the rear panel of the SSU-2000 is activated and the MAJOR ALARM LED on the front of the Communications module lights red.
- **MINOR Alarms** – A class of alarms that indicate the unit performance is degrading. The minor relay is activated and the MINOR ALARM indicator lights.

Alarms are elevated from MINOR to MAJOR to CRITICAL on a per module basis with a user-set time, from 60 to 500,000 seconds, default is (86,400 seconds or one day). The elevation time is kept in each module.

The user can select delay periods for software alarms from 0 to 86400 seconds. Changing the delay period generates an event. The setting is stored in each module. Note: if the original value is set to IMMED (-1), it means this error delay is not allowed to change and will happen immediately.

Table 6-8 lists the Communications module alarms.

Table 6-8. Communications Module Alarms

ID	Description	Alarm Level	Error Delay Default	Error Delay Settable?
0x0	Backplane Communication Errors	MINOR	5 sec	Yes
0x1	Mastership Problems	MINOR	5 sec	Yes
0x2	Loss of Power A	MINOR	Immed	No
0x3	Loss of Power B	MINOR	Immed	No
0x4	SPI Watchdog Timeout	MAJOR	Immed	No

EIA-232 Ports

The Communications module implements four EIA-232 ports that provide for local and remote communications with the SSU-2000.

A user interface (software resident in the Communications module) provides various levels of password-protected access for configuration and detailed performance monitoring and diagnostics. Use either the interactive command set or the TL1 user interface for configuring and detailed performance monitoring, see the *SSU-2000 Technical Reference*.

The ports include:

- Port A and Port B – Tied to external connectors on the rear panel of the SSU-2000 Main chassis.
- One local port – Tied to the connector on the front panel of the Communications module.
- Backplane communications port – Used to communicate with other modules in the system.

Ethernet Port

The Communications module implements one Ethernet port (10-BASE-T) that is routed to an RJ-45 connector on the rear panel of the main chassis. For more information on Ethernet settings, see [Communicating by Ethernet](#), on page 92.

Resetting the Module

The recessed RST button on the front panel of the Communications module resets the software. Use this button *only* if you cannot acquire access to the SSU-2000 using the serial or Ethernet ports. A contact closure on the Remote Reset connector on the rear panel also performs the Reset function (see [Remote Reset](#), on page 72).

Chapter 7 Input Module Reference Data

This chapter contains reference information for the Input modules available for use in the SSU-2000.

In This Chapter

- [1-Port and 3-Port E1 Input Modules](#)
- [1-Port and 3-Port DS1 Input Modules](#)
- [GPS Input Module](#)
- [Composite Clock Input Module](#)
- [Japanese Sine Wave Input Module](#)
- [Japanese Composite Clock Input Module](#)
- [Input Adapter Panels](#)

1-Port and 3-Port E1 Input Modules

This section describes the 1-Port (part number 23413014-001-0) and 3-Port (part number 23413014-002-0) E1 Input modules that may be installed in an SSU-2000 or SDU-2000 shelf.

Functional Overview

The 1-Port and 3-Port E1 Input modules receive signals and perform phase measurement comparisons with the Clock modules that are installed in the SSU-2000. The Clock modules use this information to phase and frequency lock to the incoming signal. The data may also be used for monitoring the frequency of incoming signals.

The modules accept either one or three of the following signals: sine or square wave with a frequency of 1, 1.544, 2.048, 5 or 10 MHz; or framed communication type E1. If the input signal is a communications type, the module monitors for Alarm Indication Signaling (AIS), Bipolar Violation (BPV), Loss of Signal (LOS) and Out Of Frame (OOF) errors. In addition, the module extracts Synchronization Status Messages (SSMs) from the incoming framed signals.

The E1 Input module receives signals and performs phase measurement comparisons (at a sampling rate of 40 Hz) with the Clock modules that are installed in the SSU-2000. The Clock modules use this information to phase lock to the incoming signal. The data may also be used for monitoring the frequency of incoming signals.

Functional Block Diagram

A simplified block diagram of the 1- and 3-Port E1 Input module is shown in Figure 7-1.

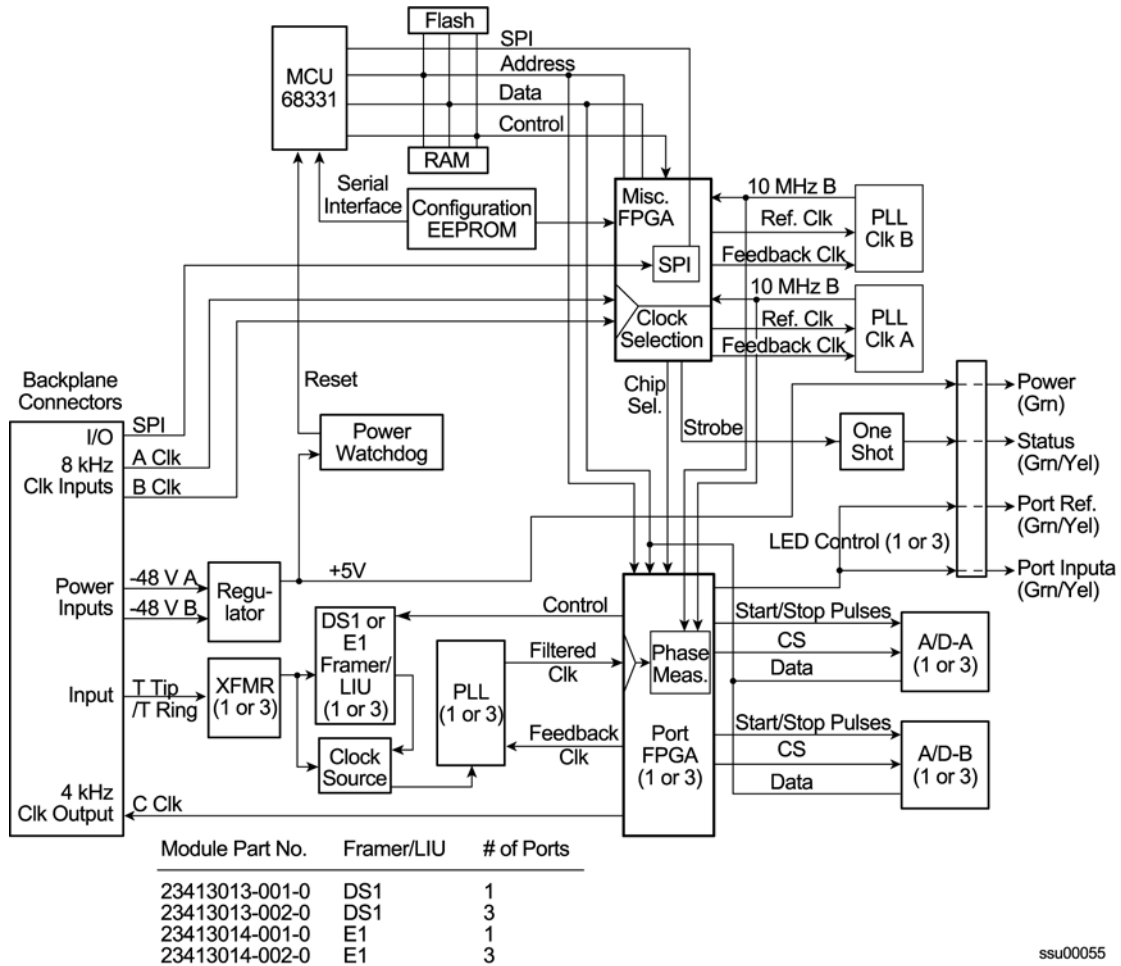

Figure 7-1. Block Diagram of the 1-Port and 3-Port E1 Input Modules

Phase Measurement Averages

The Input module maintains averages of past phase measurements including:

- 7000 100-second averages
- 700 1000-second averages
- 70 10000-second averages

To account for momentary jumps in phase, the Input module uses a phase build-out algorithm for phase jumps greater than or equal to 1 microsecond per tenth of a second. To prevent confusing frequency offsets with phase jumps, the phase build-out algorithm does not build out more than eight consecutive samples. If the phase is built out, the Input module sends an event message to the Communications module.



Note: If the SSU-2000 is configured with Clock module firmware (14113015-000-5) Revision H.00 or later, then you must DISABLE the input's PBO functionality using ICS, TL1, or SNMP commands. The PBO functionality has been moved into the Clock module and is not under software control. If you do not disable the SSU-2000's Input PBO setting, it will conflict with the PBO function in the Clock module.

The firmware running in the E1 Input module performs the following functions:

- Determines module type (distinguishes between E1 and DS1 frame chips)
- Supports unframed clock signals at the following rates: 1 MHz, 1.544 MHz, 2.048 MHz, 5.0 MHz, 10.0 MHz
- Enables/disables the Input module on command (when disabled, it does not report any alarms or measurement data and blinks the STATUS LED repeatedly)
- Enables or disables individual ports on command (disabled ports clear all existing alarms and do not report any additional alarms or measurement data)
- Maintains a provisioned SSM for each port
- Stores a priority for each port

Three-Sigma Test

The Input module uses a three-sigma test as part of the phase averaging algorithm in order to avoid the use of erroneous phase readings. In such tests, the standard deviation sigma of the phase readings is maintained. Any reading which falls more than three sigma above or below the mean is considered erroneous.

MTIE Calculation

MTIE is a measurement of the relative noisiness of an input signal. The Input module automatically (without user intervention) calculates MTIE for its inputs in accordance with the specifications in (ANSI) T1.101 and reported on demand for a 24 hour period.

MTIE data is retrieved on hour boundaries, though the stop time used may be current time. Reported time periods include: 0.05, 0.1, 1.0, 10.0, 100.0, 1000.0, 10000.0, and 100000.0 seconds.

MTIE Alarms

The Input module monitors the ongoing MTIE calculations and logs an alarm if the MTIE calculation for any of several window sizes exceeds user-set masks.

The input module software maintains two alarm masks, each with thresholds at 10, 100, 1000, 10,000, and 100,000 seconds. MTIE readings which violate either mask at any point cause an alarm at a user-set level (Minor, Major, or Critical). Refer to [Changing Factory Defaults](#), on page 113, for more information on setting alarm levels.

Although MTIE is continuously calculated against both clocks, MTIE alarms are logged only if the measurements against the currently selected clock violate one of the MTIE alarm masks.

TDEV Calculation

The Input module automatically (without user intervention) calculates TDEV (the measurement of the frequency components in a series of phase readings) for all its inputs and reports on the past 24 hours of TDEV history. TDEV is retrieved on hour boundaries, though the stop time used may be current time.

Reported time periods include: 0.05, 0.10, 0.30, 0.60, 1.0, 2.0, 3.0, 6.0, 10.0, 30.0, 60.0, 100.0, 300.0, 600.0, 1000.0, 3000.0, 6000.0, and 10000.0 seconds

The E1 Input module also contains provisions for zeroing the phase readings for one channel in response to a command from the Communications module. Once the phase is zeroed, all subsequent phase measurements are expressed in terms of how much they differ from the reading at the time the phase was zeroed.

Zeroing the phase invalidates all past phase averages, TDEV, and MTIE.

Sync Status Messages

The E1 Input module reads and processes Sync Status Messages (in accordance with specification ITU-T Composite Clock (CC) for E1 signals), to determine the traceability of inputs. This traceability information is then used by the Clock modules in selecting a reference signal and embedded into the system's outputs. For E1 inputs, an SSM is valid if three consecutive matching SSMs are received.

SSM Selection Criteria

If the E1 Input module is configured for provisioned mode, it will use the provisioned SSM. If configured for automatic mode, the Input module uses the most recent valid SSM. If a valid SSM is not received, the module uses the provisioned SSM.

E1 Input Module Alarm Modes

The E1 Input module responds to various alarm conditions according to user-set alarm levels. Each level is associated with a set of actions as follows:

Table 7-1. E1 Input Module Alarm Modes

Alarm Mode	Action	Alarm Elevation
IGNORE	Do nothing	Cannot be elevated to a higher severity level
REPORT	Do nothing	Cannot be elevated to a higher severity level
MINOR	Generate event message	Elevate to Major if the alarm condition persists beyond the user-set elevation time limit

Table 7-1. E1 Input Module Alarm Modes (Continued)

Alarm Mode	Action	Alarm Elevation
MAJOR	Generate event message	Elevate to Critical if the alarm condition persists beyond the user-set elevation time limit
CRITICAL	<ul style="list-style-type: none"> ■ Generate event message ■ Fault Port 	Cannot be elevated to a higher severity level

Alarms Caused by Hardware Problems

The following alarms are generated due to hardware problems:

- External Clock Signal PLL Unlocked
 - Report event message and perform any other actions as required by the user-set severity level
 - Fault channel, even if severity is less than MAJOR
 - Monitor PLL for recovery
- Input Signal PLL Unlocked
 - Report event message and perform other actions as required by severity
 - Fault port, regardless of severity.
 - Monitor PLL for recovery
- Phase Measurement Circuitry Fault
 - Report event message and perform any other required actions
 - Fault Port
 - Monitor phase hardware for recovery

Alarms Caused by Faulty Input Signals

The following alarms are caused by problems with the incoming input signal's formatting or content:

- Errors Tracked:
 - Framed signals: LOS, AIS, OOF, BPV and CRC
 - Unframed signals: LOS
- Error and Clear Counters

The E1 Input module maintains a count of the number of consecutive errored seconds for each error type for each port. Once this error count exceeds a user-set limit, the input signal which has experienced the errors said to be in episode. Refer to [Changing Factory Defaults](#), on page 113, for more information on setting the error count.

The Input module maintains a count of the number of consecutive seconds in which the input signal for each port is *free* of each type of error. This clear count must exceed a user-set limit before the input signal is no longer in episode. Refer to [Changing Factory Defaults](#), on page 113, for more information on setting the clear count.

Handling Input Signal Faults

For LOS (loss of signal) and before going into episode:

- Coast over brief occurrences of LOS, reporting the last known good phase measurements for the port until signal returns or the signal goes into episode
- The duration of a brief occurrence of LOS is defined by the value of the error count for LOS. The default is 10 seconds.

Once in episode:

- Log LOS alarm, taking appropriate action per the assigned severity level
- Invalidate current phase measurements
- Others (AIS, BPV, CRC, and OOF)

Once in episode, the system takes appropriate action according to the severity level assigned to the alarm.

LOS Phase Considerations

- Phase reading not valid when in episode
- Zero phase reading when episode ends
- If signal returns before the port goes into episode, normalize subsequent phase measurements to show continuous phase numbers before and after the loss of signal.
- Others
- Phase reading valid

Hierarchy of Alarm Signals

- LOS
- AIS
- OOF
- BPV/CRC

The Input module does not report alarms below the level of an active alarm.

Cesium Fault

- Facilitates compatibility with older Hewlett Packard units
- Only valid if port one is configured to receive an unframed input signal

- User can select high or low logic level as alarmed
- If the hardware indicates that the cesium fault level matches the alarmed setting, log an AIS alarm against port 1
- Clear the alarm when the hardware's cesium fault level no longer matches the alarmed level

Input Measurement Problems

If the MTIE values for a selected clock exceed either of the MTIE masks, the Input module takes appropriate action according to the severity level associated with the MTIE alarms.

If a received SSM has a lower PQL than the provisioned value assigned to the port and the port has SSMs enabled, the Input module performs the action required by the alarm mode.

E1 Input Module Events Reported

The E1 Input module reports the event types listed in [Table 7-2](#) when they occur:

Table 7-2. E1 Input Module Event Reporting

Event	Parameter One	Parameter Two
Module installed	–	–
Module enabled	–	–
Module disabled	–	–
Module restarted	Delay before restart (in s)	–
Input Signal Episode, Alarm, and Faults	–	–
Hardware Faults	–	–
Received SSM Changed	New PQL	Old PQL
Phase Buildout	Phase value being built out	<i>Corrected</i> phase value
Configuration Changes	New Value (if necessary)	Old Value (if not implied by new value)
Input phase zeroed	–	–

Status LED Indicators

The E1 Input module is equipped with a set of status LED indicators that indicate module and incoming signal status. These LEDs are shown in [Figure 7-2](#) (3-port model illustrated) and described in [Table 7-3](#).

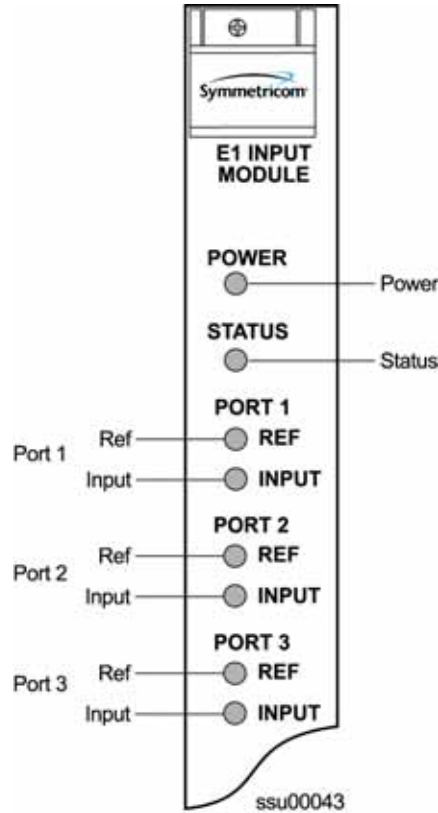

Figure 7-2. Front Panel of the E1 Input Module

Table 7-3. E1 Input Module Status LED Indicators

Indicator	Color	Description
POWER	Green	On = The module is receiving +5 V DC
STATUS	Green/Amber	Green = Unit is in Normal mode of operation; no faults Amber = Fault condition detected Blinking (Amber) = Firmware downloading or disabled
PORT 1 REF	Green/Amber	On = Selected Reference Off = Disabled, or good and not selected
PORT 1 INPUT	Green/Amber	On (Green) = Enabled and signal valid, no major alarms On (Amber) = Enabled and signal not valid Off = Disabled
PORT 2 REF	Green/Amber	On = Selected Reference Off = Disabled, or good and not selected
PORT 2 INPUT	Green/Amber	On (Green) = Enabled and signal valid, no major alarms On (Amber) = Enabled and signal not valid Off = Disabled

Table 7-3. E1 Input Module Status LED Indicators (Continued)

Indicator	Color	Description
PORT 3 REF	Green/Amber	On = Selected Reference Off = Disabled, or good and not selected
PORT 3 INPUT	Green/Amber	On (Green) = Enabled and signal valid, no major alarms On (Amber) = Enabled and signal not valid Off = Disabled

Software Options

The factory settings and ranges for all E1 Input module software parameters are listed in [Table 7-4](#).

Table 7-4. E1 Input Module Configuration

Configuration Setting	Factory Default	Range
Framing Enabled	On/On/Off	On/Off
Input Frequency (for unframed signals)	10 MHz	1 MHz, 1.544 MHz, 2.048 MHz, 5 MHz, 10 MHz
Framing Type	CCS	CAS or CCS
Zero Suppression	On	On/Off
CRC	Off	On/Off
SSM	Off	On/Off
Provisioned PQL	3/4/3	1–16
Priority	0	0 to 10 (0 = Monitor)
E1 Bit Position	8	4 to 8
Cesium Fault Nominal	Low	Low/High/Off
Input Signal Error Limit	10 seconds	1 to 100 for LOS and AIS, 1 to 10000 for BPV, CRC and OOF
MTIE T10 Limit1	325/1000/325	0 to 100000
MTIE T10 Limit2	330/1010/330	0 to 100000
MTIE T100 Limit1	550/2000/550	0 to 100000
MTIE T100 Limit 2	560/2010/560	0 to 100000
MTIE T1000 Limit1	1010/2000/1010	0 to 100000
MTIE T1000 Limit2	1020/2010/1020	0 to 100000
MTIE T10000 Limit 1	1100/2835/1100	0 to 100000

Table 7-4. E1 Input Module Configuration

Configuration Setting	Factory Default	Range
MTIE T10000 Limit 2	1110/2840/1110	0 to 100000
MTIE Limit 1 Alarm Mode	Minor	Ignore, Report, Minor, Major, or Critical
MTIE Limit 2 Alarm Mode	Major	Ignore, Report, Minor, Major, or Critical
Alarm Initial Severity	Minor (except LOS and level 2 MTIE, which are Major)	Ignore, Report, Minor, Major, or Critical
Alarm Initial Delay	0 seconds	0 to 86400 seconds
Alarm Elevation Time	86400 seconds	0 to 500000 seconds
Port Status	Disabled	Enabled/Disabled
Port Name		Any user-selected string from 0 to 20 characters

1-Port and 3-Port DS1 Input Modules

This section describes the 1-Port (part number 23413013-001-0) and 3-Port (part number 23413013-002-0) DS1 Input modules that may be installed in an SSU-2000.

The 1-Port and 3-Port DS1 Input modules receive signals and perform phase measurement comparisons with the Clock modules that are installed in the SSU-2000. The Clock modules use this information to phase and frequency lock to the incoming signal. The data may also be used for monitoring the frequency of incoming signals.

The input ports accept one (1-Port Input modules), or three (3-Port Input modules) of the following signals: sine or square wave, with frequency of 1, 1.544, 2.048, 5 or 10 MHz, or framed communication type DS1. If the input signal is a communications type, the module monitors for Alarm Indication Signaling (AIS), Bipolar Violations (BPVs), Loss of Signal (LOS) and Out Of Frame (OOF) errors. In addition, the module extracts Synchronization Status Messages (SSMs) from the incoming data.

Functional Overview

The DS1 Input module (1-port and 3-port versions) consists of a microcontroller and firmware, SRAM for data storage, FLASH (contains the firmware), input signal ports, and other support circuitry. The primary function of these modules is to perform time-interval-measurements on Clock module A and Clock module B, using the reference input signals. These measurements are used to adjust the frequency of the oscillators on the two Clock modules.

Functional Block Diagram

A simplified block diagram of the 1- and 3-Port DS1 Input modules is shown in [Figure 7-3](#).

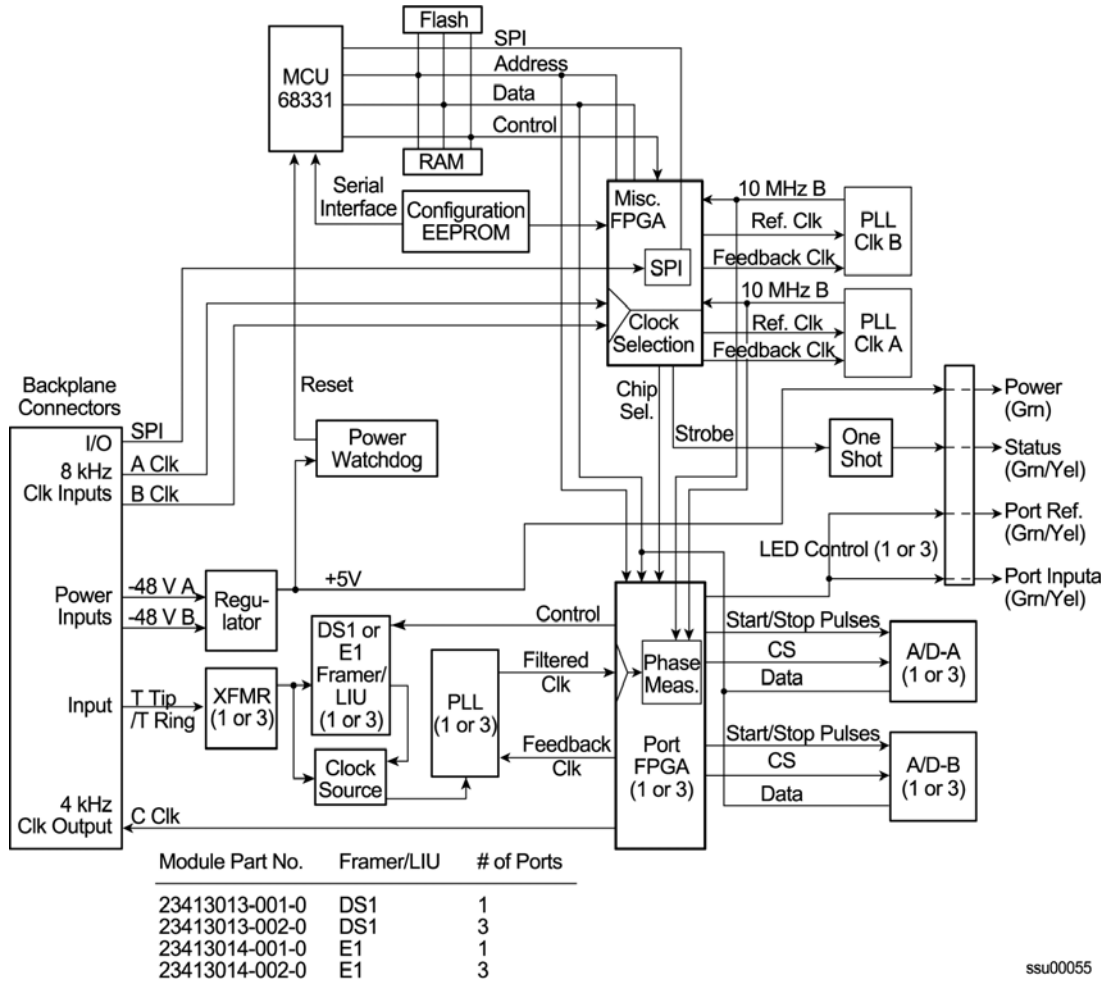

Figure 7-3. Block Diagram of the 1-Port and 3-Port DS1 Input Module

Phase Measurement Averages

The Input module also maintains averages of past phase measurements including:

- 1000 one-second averages
- 1000 100-second averages
- 100 1000-second averages
- 10 10000-second averages

To account for momentary jumps in phase, the Input module uses a phase buildout algorithm for phase jumps greater than or equal to 1 microsecond per tenth of a second. To prevent confusing frequency offsets for phase jumps, the phase build out algorithm does not build out more than eight consecutive samples. If the phase is *built out*, the Input module sends an event message to the Communications module.



Note: If the SSU-2000 is configured with Clock module firmware (14113015-000-5) Revision H.00 or later, then you must DISABLE the input's PBO functionality using ICS, TL1, or SNMP commands. The PBO functionality has been moved into the Clock module and is not under software control. If you do not disable the SSU-2000's Input PBO setting, it will conflict with the PBO function in the Clock module.

Three-Sigma Test

The Input module uses a three-sigma test as part of the phase averaging algorithm in order to avoid the use of erroneous phase readings. In such tests, the standard deviation, sigma, of the phase readings is maintained. Any reading which falls more than three sigma above or below the mean is considered erroneous.

MTIE Calculation

MTIE is a measurement of the relative noisiness of an input signal. The Input module automatically (without user intervention) calculates MTIE for its inputs in accordance with the specifications in (ANSI) T1.101 and reported on demand for a 24 hour period.

MTIE data is retrieved on hour boundaries, though the stop time used may be current time. Reported time periods include 0.05, 0.1, 1.0, 10.0, 100.0, 1000.0, 10000.0, and 100000.0 seconds.

MTIE Alarms

The Input module monitors the ongoing MTIE calculations and logs an alarm if the MTIE calculation for any of several window sizes exceeds user-set masks.

The Input module software maintains two alarm masks, each with thresholds at 10, 100, 1000, and 10000 seconds. MTIE readings which violate either mask at any point cause an alarm at a user-set level. Refer to [Changing Factory Defaults](#), on page 113, for more information on setting alarm levels.

Although MTIE is continuously calculated against both clocks, MTIE alarms are logged only if the measurements against the currently selected clock violate one of the MTIE alarm masks.

TDEV Calculation

The Input module automatically (without user intervention) calculates TDEV (the measurement of the frequency components in a series of phase readings) for all its inputs and reports on the past 24 hours of TDEV history. TDEV is retrieved on hour boundaries, though the stop time used may be current time. Reported time periods include 0.05, 0.10, 0.30, 0.60, 1.0, 2.0, 3.0, 6.0, 10.0, 30.0, 60.0, 100.0, 300.0, 600.0, 1000.0, 3000.0, 6000.0, and 10,000.0 seconds.

The Input module also contains provisions for zeroing the phase readings for one channel in response to a command from the Communications module. Once the phase is zeroed, all subsequent phase measurements are expressed in terms of how much they differ from the reading at the time the phase was zeroed. Zeroing the phase invalidates all past phase averages, TDEV, and MTIE.

Synchronization Status Messages

The Input module reads and processes Synchronization Status Messages (in accordance with specifications (ANSI) T1.403 for DS1 signals), to determine the traceability of inputs. This traceability information is then used by the Clock modules in selecting a reference signal and embedded into the system's outputs. See

For a DS1 input signal, an SSM is considered valid only after seven of the last ten received SSMs match. For DS1 signals, the Input module logs an alarm (user-set level) if 10 seconds elapse and no SSM is detected.

SSM Selection Criteria

If the Input module is configured for provisioned mode, it will use the provisioned SSM. If configured for automatic mode, the Input module uses the most recent valid SSM. If a valid SSM is not received, the module uses the provisioned SSM. Refer to [Changing Factory Defaults](#), on page 113, for more information on SSM settings.

DS1 Input Module Alarm Modes

The Input module responds to various alarm conditions according to user-set alarm levels. Each level is associated with a set of actions (or non-actions) as shown in [Table 7-5](#).

Table 7-5. DS1 Input Module Alarm Modes

Alarm Mode	Action	Alarm Elevation
IGNORE	Do nothing	Cannot be elevated to a higher severity level
REPORT	Do nothing	Cannot be elevated to a higher severity level
MINOR	Generate event message	Elevate to Major if the alarm condition persists beyond the user-set elevation time limit
MAJOR	Generate event message	Elevate to Critical if the alarm condition persists beyond the user-set elevation time limit
CRITICAL	<ul style="list-style-type: none"> ■ Generate event message ■ Fault Port 	Cannot be elevated as there is no higher severity level

Alarms Caused by Hardware Problems

The following alarms are generated due to hardware problems:

- External Clock Signal PLL Unlocked
 - Report event message and perform any other actions as required by the user-set severity level
 - Fault channel, even if severity is less than MAJOR
 - Monitor PLL for recovery
- Input Signal PLL Unlocked
 - Report event message and perform other actions as required by severity
 - Fault port, regardless of severity
 - Monitor PLL for recovery
- Phase Measurement Circuitry Fault
 - Report event message and perform any other required actions
 - Fault Port
 - Monitor phase hardware for recovery

Handling Input Signal Faults

The following alarms are caused by problems with the incoming input signal's formatting or content:

- Errors Tracked:
 - Framed signals: LOS, AIS, OOF, BPV and CRC
 - Unframed signals: LOS
- Error and Clear Counters

The Input module maintains a count of the number of consecutive errored seconds for each error type for each port. Once this error count exceeds a user-set limit, the input signal which has experienced the errors is said to be in episode.

The Input module maintains a count of the number of consecutive seconds in which the input signal for each port was free of each type of error. This clear count must exceed a user-set limit before the input signal is no longer in episode.

Handling Input Signal Faults

For LOS (loss of signal) and before going into episode:

- Coast over brief occurrences of LOS, reporting the last known good phase measurements for the port until signal returns or the signal goes into episode
- The duration of a brief occurrence of LOS is defined by the value of the error count for LOS

Once in episode:

- Log LOS alarm, taking appropriate action per the assigned severity level
- Invalidate current phase measurements

Others (AIS, BPV, CRC, and OOF)

Once in episode, take appropriate action according to the severity level assigned to the alarm.

LOS Phase Considerations

- Phase reading not valid when in episode
- Zero phase reading when episode ends
- If signal returns before the port goes into episode, normalize subsequent phase measurements to show continuous phase numbers before and after the loss of signal
- Others
- Phase reading valid

Hierarchy of Signal Faults

The following alarms are listed in the order of most to least severe:

- LOS
- AIS
- OOF
- BPV/CRC

The Input module does not report alarms below the level of an active alarm.

Cesium Fault

- Facilitates compatibility with older Hewlett Packard units
- Only valid if port one is configured to receive an unframed input signal
- User can select high or low logic level as alarmed
- If the hardware indicates that the cesium fault level matches the alarmed setting, log an AIS alarm against port 1
- Clear the alarm when the hardware's cesium fault level no longer matches the alarmed level

Input Measurement Problems

If the MTIE values for a selected clock exceed either of the MTIE masks, the Input module takes appropriate action according to the severity level associated with the MTIE alarms. If a received SSM has a lower PQL than the provisioned value assigned to the port and the port has SSMs enabled, the Input module performs the action required by the alarm mode. Refer to the ALARM command described in the *SSU-2000 Technical Reference*, for more information on alarm settings.

DS1 Input Module Events Reported

The 3-Port DS1 Input module reports the event types listed in [Table 7-6](#) when they occur. See Chapter 6 of the *SSU-2000 Technical Reference* for more information on events.

Table 7-6. DS1 Input Module Event Reporting

Event	Parameter One	Parameter Two
Card installed	–	–
Card enabled	–	–
Card disabled	–	–
Card restarted	Delay before restart (in s)	–
Input Signal Episode, Alarm, and Faults	–	–
Hardware Faults	–	–
Received SSM Changed	New PQL	Old PQL
Phase Buildout	Phase value being built out	Corrected phase value
Configuration Changes	New Value (if necessary)	Old Value (if not implied by new value)
Input phase zeroed	–	–

Status LED Indicators

The DS1 Input module is equipped with eight status LEDs that indicate module status. These LEDs are shown in [Figure 7-4](#) and are described in [Table 7-7](#).

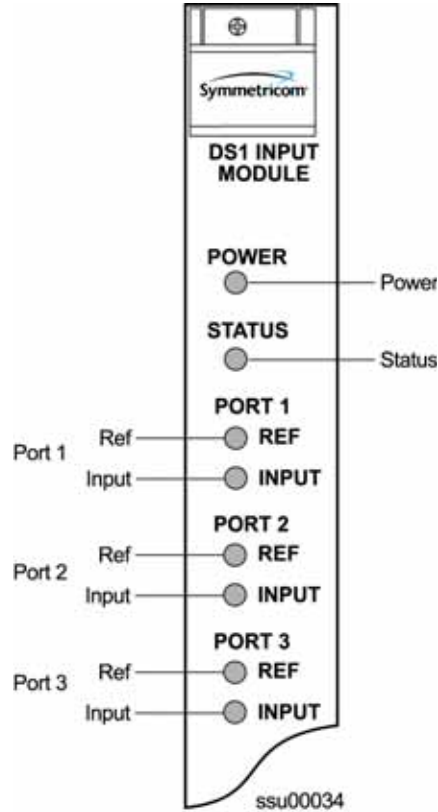

Figure 7-4. Front Panel of the DS1 Input Module

Table 7-7. DS1 Input Module Status LED Indicators

Indicator	Color	Description
POWER	Green	On = The module is receiving +5 V DC
STATUS	Green/Amber	Green = Unit is in Normal mode of operation; no faults. Amber = Fault condition detected Blinking = Disabled or firmware upgrade in progress
PORT 1 REF	Green	On = Selected Reference Off = Disabled, or good and not selected
PORT 1 INPUT	Green/Amber	On (Green) = Enabled and signal valid, no major alarms On (Amber) = Enabled and signal not valid Off = Disabled
PORT 2 REF	Green	On = Selected Reference Off = Disabled, or good and not selected
PORT 2 INPUT	Green/Amber	On (Green) = Enabled and signal valid, no major alarms On (Amber) = Enabled and signal not valid Off = Disabled

Table 7-7. DS1 Input Module Status LED Indicators (Continued)

Indicator	Color	Description
PORT 3 REF	Green	On = Selected Reference Off = Disabled, or good and not selected
PORT 3 INPUT	Green/Amber	On (Green) = Enabled and signal valid, no major alarms On (Amber) = Enabled and signal not valid Off = Disabled

Configuration Options

The factory settings and ranges for all DS1 Input module software parameters are listed in [Table 7-8](#).

Table 7-8. DS1 Input Module Configuration

Configuration Setting	Factory Default	Range
Framing Enabled	On/On/Off	On/Off
Input Frequency (for unframed signals)	10 MHz	1 MHz, 1.544 MHz, 2.048 MHz, 5 MHz, 10MHz
Framing Type	ESF	D4 or ESF
Zero Suppression	On	On/Off
CRC	Off	On/Off
SSM	Off	On/Off
Provisioned PQL	3/4/3	1 to 16
Priority	0	0 to 10 (0 = Monitor)
Cesium Fault Nominal	Low	Low/High/Off
Input Signal Error Limit	10 seconds	1 to 100 for LOS and AIS 1 to 10000 for BPV, CRC and OOF
MTIE T10 Limit1	325/1000/325	0 to 100000
MTIE T10 Limit2	330/1010/330	0 to 100000
MTIE T100 Limit1	550/2000/550	0 to 100000
MTIE T100 Limit 2	560/2010/560	0 to 100000
MTIE T1000 Limit1	1010/2000/1010	0 to 100000
MTIE T1000 Limit2	1020/2010/1020	0 to 100000
MTIE T10000 Limit 1	1100/2835/1100	0 to 100000
MTIE T10000 Limit 2	1110/2840/1110	0 to 100000

Table 7-8. DS1 Input Module Configuration (Continued)

Configuration Setting	Factory Default	Range
MTIE Limit 1 Alarm Mode	Minor	Ignore, Report, Minor, Major, or Critical
MTIE Limit 2 Alarm Mode	Major	Ignore, Report, Minor, Major, or Critical
Alarm Initial Severity	Minor (except LOS and level 2 MTIE, which are Major)	Ignore, Report, Minor, Major, or Critical
Alarm Initial Delay	0 seconds	0 to 86400 seconds
Alarm Elevation Time	86400 seconds	0 to 500000 seconds
Port Status	Disabled	Enabled/Disabled
Port Name		Any user selected string from 0 to 20 characters

GPS Input Module

This section provides user-reference data for the GPS Input module (part number 23413019-000-0) that is used in the SSU-2000 main chassis to provide a timing reference signal to phase and frequency lock the internal clocks and to produce phase locked output signals.

Functional Overview

The module consists of a microcontroller and firmware, SRAM for data storage, FLASH (which contains the firmware), a GPS receiver (radio), and other support circuitry. The primary function of these modules is to perform time-interval measurements on Clock module A and Clock module B, using the 1PPS provided by the radio. These measurements are used to adjust the frequency of the oscillators on those modules.

In addition, this module supports the Network Time Protocol (NTP), which is a function provided by the Communications module. Time-of-day from the Radio is transferred to the Communications module for distribution to clients connected to the same network. The Communications module's internal 1PPS is synchronized to the 1PPS from the Radio.

The GPS Input modules monitor and report the status and performance of the module and the received radio signals. Each module type communicates with the Communications module to receive user configuration commands and to report status and performance back to the Clock modules for frequency control.

Functional Block Diagram

A simplified block diagram of the GPS Input module is shown in Figure 7-5.

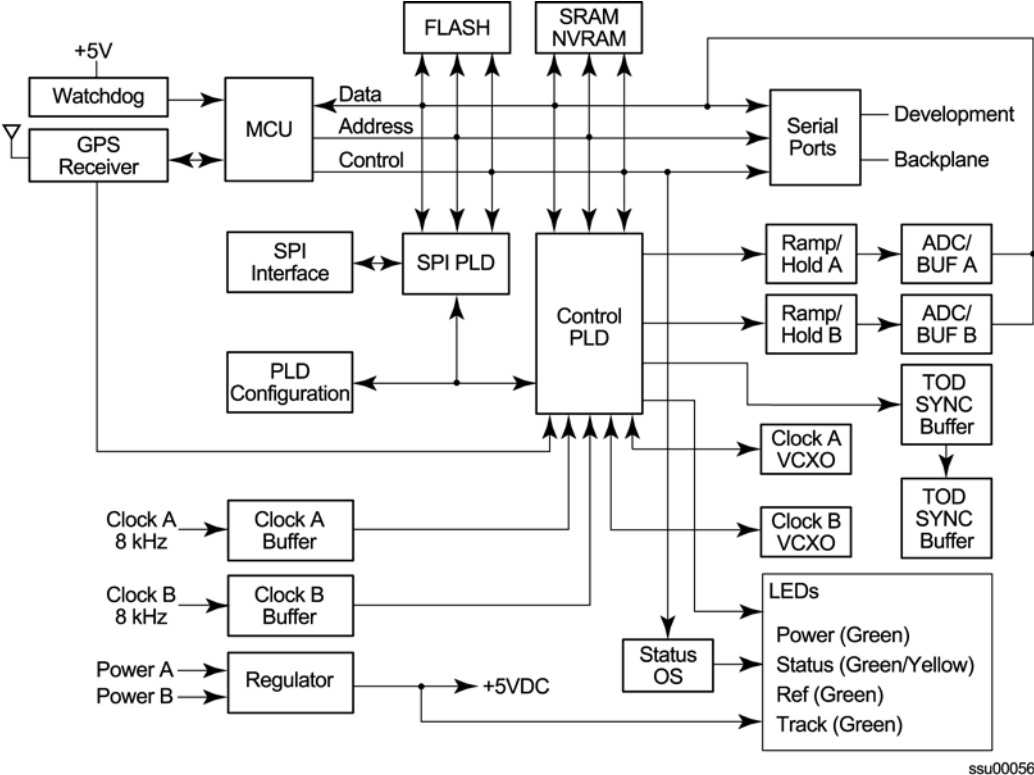

Figure 7-5. Block Diagram of the GPS Input Module

Status LED Indicators

The GPS Input module is equipped with four status LEDs as shown in [Figure 7-6](#). The LED status assignments are described in [Table 7-9](#).

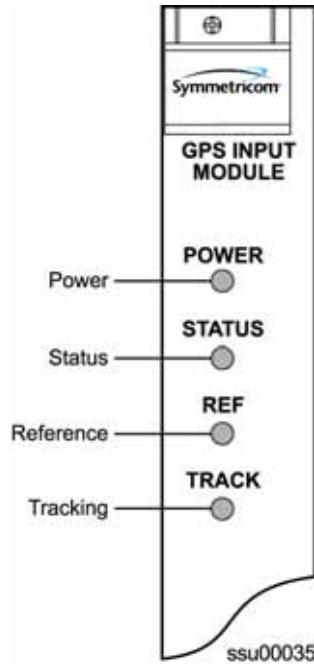

Figure 7-6. Front Panel of the GPS Input Module

Table 7-9. GPS Input Module Status LED Indicators

Indicator	Color	Description
POWER	Green	On = The module is receiving +5 V DC
STATUS	Green/Amber	On (Green) = Unit is in Normal mode of operation; no faults On (Amber) = Fault condition detected (firmware timed out) Blinking (Amber) = Firmware uploading or Antenna not connected
REF	Green	On = Selected Reference Off = Disabled, or good and not selected
TRACK	Green/Amber	On (Green) = Radio is tracking On (Amber) = Tracking problem without antenna fault Blinking (Amber) = Antenna fault

Configuration Options

The configuration settings for the GPS Input module are listed in [Table 7-10](#).

Table 7-10. GPS Input Module Configuration Settings

Configuration Setting	Factory Default	Range
Position (GPS only)		
Latitude	0	± 90 degrees
Longitude	0	±180 degrees
Altitude	0	-60 to 4000 meters
Averages	300	10 to 3600
PDOP	0	1 to 10
Pos Mode	Calc	User/Calc
Min Elevation for position	5	0 to 50 degrees
Min PDOP for position	3	1 to 10
Min Elevation for timing	10	0 to 50 degrees
Module Status	Enabled	Enabled/Disabled
Priority	0	0 to 10
Sigma limit	25	10 to 1000 μS
PQL	2	1 to 16
Disabled SV list	None	Up to 31 SV numbers
Min PDOP for position	3	1 to 10

Composite Clock Input Module

This section provides operating instructions and software provisioning procedures for the Composite Clock Input module (part number 23413279-000-0), designed for use in the SSU-2000 Synchronization Supply Unit.

Functional Overview

The Composite Clock Input module conditions a composite clock input signal that is used to control the frequency of the Clock modules. When the SSU-2000 is in the Subtending mode, it also produces a 4 kHz synchronization signal, which determines the phase of the composite clock signals generated by Composite Clock Output modules. This signal ensures that the phase of the composite clock output signals follows the phase of the composite clock input reference signal. The module consists of a microcontroller and firmware, SRAM for data storage, FLASH memory that contains the firmware, and other support circuitry.

The module monitors and reports module status and conditions. Events are generated for Loss of Signal (LOS) and Bipolar Violation (BPV) density. Each module communicates with the Communications module to receive user configuration commands and to report status and performance for the Clock modules for frequency control.

Functional Block Diagram

A simplified block diagram of the Composite Clock Input module is shown in [Figure 7-7](#).

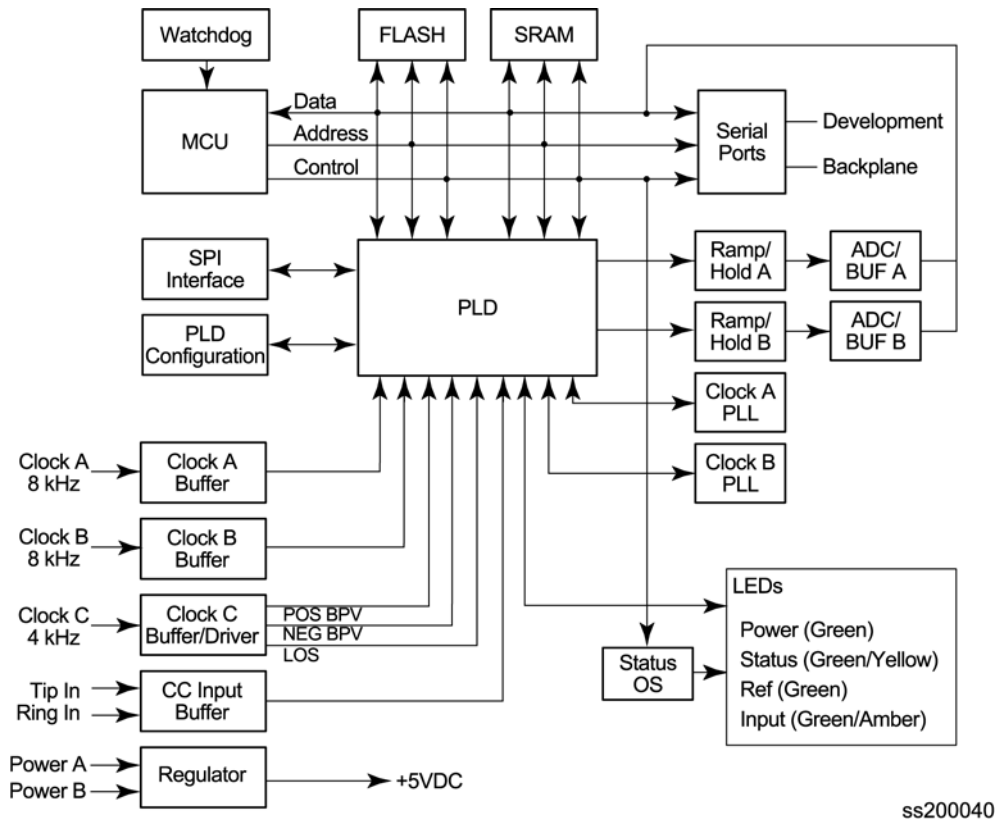

Figure 7-7. Block Diagram of the Composite Clock Input Module

Status LED Indicators

The CC Input module is equipped with four status LEDs as shown in [Figure 7-8](#). The LED status assignments are described in [Table 7-9](#).

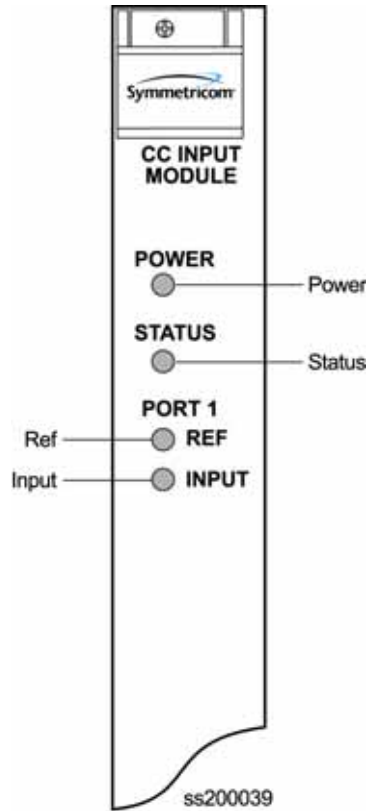

Figure 7-8. Front Panel of the Composite Clock Input Module

Table 7-11. Composite Clock Input Module Status LED Indicators

Indicator	Color	Description
POWER	Green	On = The module is receiving +5 V DC
STATUS	Green/Amber	On (Green) = Unit is in Normal mode of operation; no faults On (Amber) = Fault condition detected Blinking = Disabled or firmware upgrade in progress
REF	Green	On = Selected Reference Off = Disabled, or good and not selected
INPUT	Green/Amber	On (Green) = Enabled and signal valid, no major alarms On (Amber) = Enabled and signal not valid Off = Disabled

Configuration Options

The configuration settings for the Composite Clock Input module are listed in [Table 7-12](#).

Table 7-12. Composite Clock Input Module Configuration Settings

Configuration Setting	Factory Default	Range
Provisioned PQL	4	1 – 16
Priority	0	1 – 10 (0 = Monitor)
Input Signal Error Limit	LOS = 1, BPV = 1	LOS: 1 – 100 BPV: 1 – 100000
Input Signal Clear Limit	LOS = 5, BPV = 5	LOS: 1 – 100 BPV: 1 – 100000
Alarm Elevation Time	86400 seconds	0 – 500000 seconds
Port Status	Enabled	Enabled/Disabled
Port Name	None (blank)	Any string from 0 – 20 characters

Japanese Sine Wave Input Module

This section describes the Japanese Sine Wave Input module (part number 23413305-000-0). It provides details on operation, configuration, alarms, events, and specifications.

Functional Overview

The Input module accepts up to three input signals of either 1.544 MHz or 6.312 MHz and performs phase measurement comparisons (at a sampling rate of 40 Hz) with the Clock modules. The Clock modules use this information to phase and frequency lock to the incoming signal. The data can also be used for monitoring the frequency of incoming signals.

The Input module consists of a microcontroller and firmware, SRAM for data storage, FLASH (contains the firmware), input signal ports, and other support circuitry. The primary function of the module is to perform time-interval measurements on Clock module A and Clock module B using the reference input signals. These measurements are used to adjust the frequency of the oscillators on the two Clock modules.

Functional Block Diagram

A simplified block diagram of the Japanese Sine Wave Input module is shown in Figure 7-9.

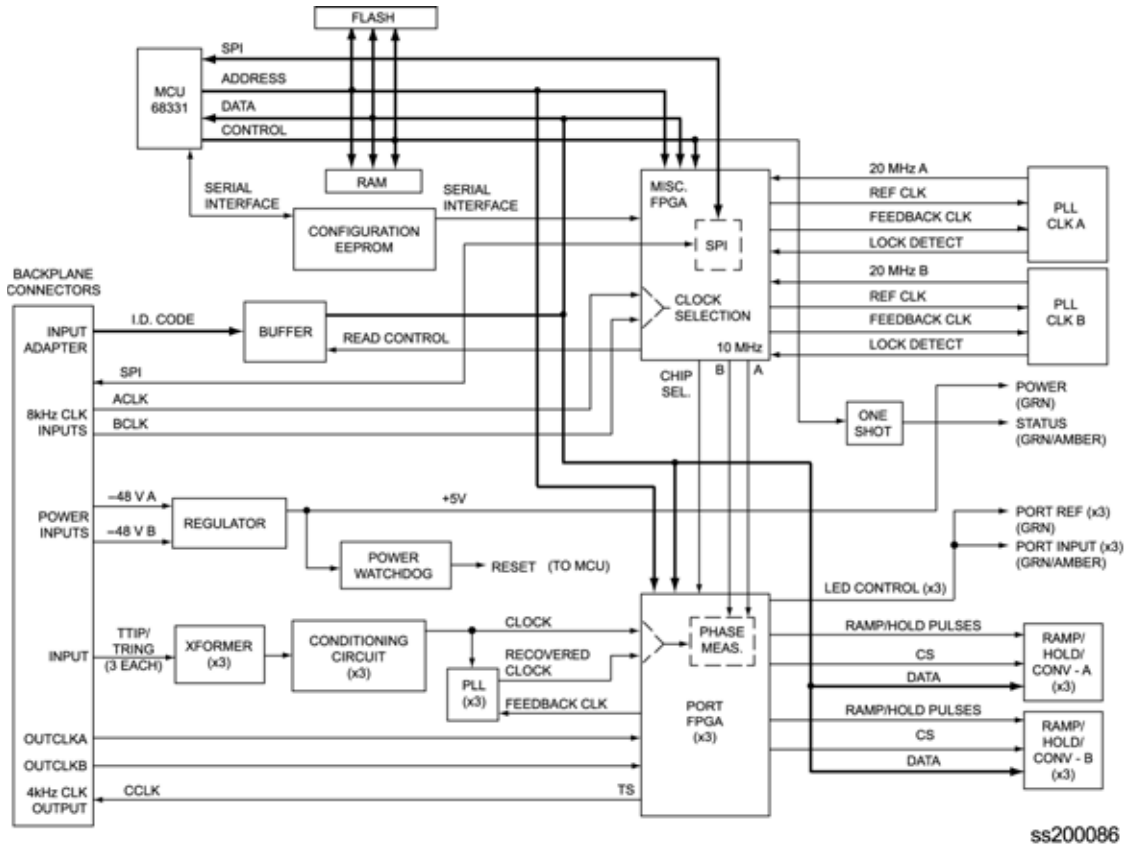

Figure 7-9. Block Diagram of the Japanese Sine Wave Input Module

Phase Measurement

The Input module reports a one-second phase average every second to the Communications module and Clock modules. The Communications module retrieves seven days of 100-second, 1000-second, and 10000-second averages from the Input module.

To account for momentary jumps in phase, the Input module uses a phase buildout algorithm for phase jumps greater than or equal to one microsecond per tenth of a second. To prevent confusing frequency offsets for phase jumps, the phase buildout algorithm does not build out more than eight consecutive samples. If the phase is *built out*, the system can be provisioned to generate events indicating that a PBO (phase build-out) has occurred.



Note: If the SSU-2000 is configured with Clock module firmware (14113015-000-5) Revision H.00 or later, then you must DISABLE the input's PBO functionality using ICS, TL1, or SNMP commands. The PBO functionality has been moved into the Clock module and is not under software control. If you do not disable the SSU-2000's Input PBO setting, it will conflict with the PBO function in the Clock module.

Frequency Alarms

The Input module measures the phase difference over time of an input signal and calculates the input frequency. The frequency calculation has a frequency measurement resolution of $2.5E^{-12}$.

The module monitors the ongoing Frequency calculations and logs an alarm if the frequency calculation exceeds either of the two user-settable alarm masks. Frequency readings that violate either mask at any point cause an alarm at a user-set severity level. Refer to [Changing Factory Defaults](#), on page 113 for more information on setting alarm levels.

Although Frequency is continuously calculated against both clocks, frequency alarms are logged only if the measurements against the currently selected clock violate one of the frequency alarm masks.

MTIE Calculation

Maximum Time Interval Error (MTIE) is a measurement of the relative noisiness of an input signal. The Input module automatically (without user intervention) calculates MTIE for its inputs in accordance with the specifications in ANSI T1.101 and ITU 812 and generates reports on demand for a 24-hour period.

MTIE data is retrieved on hour boundaries, though the stop time used can be current time. Reported time periods include 0.05, 0.1, 10.0, 100.0, 1000.0, 10000.0, and 100000.0 seconds.

MTIE Alarms

The Input module monitors the ongoing MTIE calculations and logs an alarm if the MTIE calculation for any of several window sizes exceeds user-set masks.

The Input module software maintains two alarm masks, each with thresholds at 10, 100, 1000, 10000, and 100000 seconds. MTIE readings which violate either mask at any point cause an alarm at a user-set level. Refer to [Changing Factory Defaults](#), on page 113 for more information on setting alarm levels.

Although MTIE is continuously calculated against both clocks, MTIE alarms are logged only if the measurements against the currently selected clock violate one of the MTIE alarm masks.

TDEV Calculation

The Input module automatically (without user intervention) calculates Time Deviation (TDEV), which is the measurement of the frequency components in a series of phase readings, for all its inputs and reports on the past 24 hours of TDEV history. TDEV is retrieved on hour boundaries, though the stop time used may be current time.

Reported time periods include 0.05, 0.10, 0.30, 0.60, 1.0, 2.0, 3.0, 6.0, 10.0, 30.0, 60.0, 100.0, 300.0, 600.0, 1000.0, 3000.0, 6000.0, and 10000.0 seconds.

The Input module also contains provisions for zeroing the phase readings for one channel in response to a command from the Communications module. Once the phase is zeroed, all subsequent phase measurements are expressed in terms of how much they differ from the reading at the time the phase was zeroed. Zeroing the phase invalidates all past phase averages, TDEV, and MTIE.

Alarms Caused by Hardware Problems

The following alarms are generated due to hardware problems:

- External Clock Signal PLL Unlocked
 - Report event message and perform any other actions as required by the user-set severity level
 - Fault channel, even if severity is less than MAJOR
 - Monitor PLL for recovery
- Input Signal PLL Unlocked
 - Report event message and perform other actions as required by severity
 - Fault port, regardless of severity
 - Monitor PLL for recovery
- Phase Measurement Circuitry Fault
 - Report event message and perform any other required actions
 - Fault Port
 - Monitor phase hardware for recovery



Note: Loss of Signal (LOS) and Error and Clear Counters alarms are caused by problems with the incoming input signal.

Loss of Signal

For LOS and before going into episode:

- Coast over brief occurrences of LOS, reporting the last known good phase measurements for the port until signal returns or the signal goes into episode
- The duration of a brief occurrence of LOS is defined by the value of the error count for LOS

Once in episode:

- Log LOS alarm, taking appropriate action per the assigned severity level

- Invalidate current phase measurements

LOS Phase Considerations

- Phase reading not valid when in episode
- Zero phase reading when episode ends
- If signal returns before the port goes into episode, normalize subsequent phase measurements to show continuous phase numbers before and after LOS
- Others
- Phase reading valid

Measurement Problems

If the MTIE values for a selected clock exceed either of the MTIE masks, the Input module takes appropriate action according to the severity level associated with the MTIE alarms. Refer to the ALARM command described in the *SSU-2000 Technical Reference* for more information on alarm settings.

Status LED Indicators

The Japanese Sine Wave Input module is equipped with eight status LEDs as shown in [Figure 7-10](#). The LED status assignments are described in [Table 7-13](#).

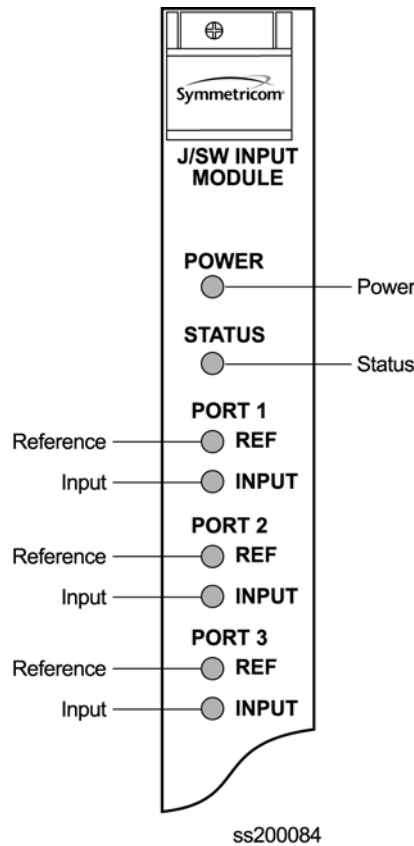

Figure 7-10. Front Panel of the Japanese Sine Wave Input Module

Table 7-13. Japanese Sine Wave Input Module Status LED Indicators

Indicator	Color	Description
POWER	Green	On = The module is receiving +5 V DC Off = +5 V DC not present on the module
STATUS	Green/Amber	On (Green) = Unit is in Normal mode of operation; no faults On (Amber) = Fault condition detected Blinking = Disabled or firmware upgrade in progress
PORT 1 REF	Green	On = Selected Reference Off = Disabled, or good and not selected
PORT 1 INPUT	Green/Amber	On (Green) = Enabled and signal valid On (Amber) = Enabled and signal not valid Off = Disabled
PORT 2 REF	Green	On = Selected Reference Off = Disabled, or good and not selected
PORT 2 INPUT	Green/Amber	On (Green) = Enabled and signal valid On (Amber) = Enabled and signal not valid Off = Disabled
PORT 3 REF	Green	On = Selected Reference Off = Disabled, or good and not selected
PORT 3 INPUT	Green/Amber	On (Green) = Enabled and signal valid On (Amber) = Enabled and signal not valid Off = Disabled

Configuration Options

The configuration settings for the Japanese Sine Wave Input module are listed in [Table 7-14](#).

Table 7-14. Japanese Sine Wave Input Module Configuration Settings

Configuration Setting	Factory Default	Range
Input Frequency (for unframed signals)	6.312 MHz	1.544 MHz 6.312 MHz
Provisioned PQL	4	1–16
Priority	1	0–10 (0 = Monitor)
FREQ Set ClkA	16000	0 to 10 000 000
FREQ Set ClkB	16000	0 to 10 000 000
FREQ Clear ClkA	12000	0 to 10 000 000
FREQ Clear ClkB	12000	0 to 10 000 000

Table 7-14. Japanese Sine Wave Input Module Configuration Settings (Continued)

Configuration Setting	Factory Default	Range
Frequency Alarm Mode	Major	Ignore, Report, Minor, Major or Critical
MTIE T10 Set Limit1	260/80/260	0 to 100 000
MTIE T10 Set Limit2	325/100/325	0 to 100 000
MTIE T100 Set Limit1	440/800/440	0 to 100 000
MTIE T100 Set Limit 2	550/100/550	0 to 100 000
MTIE T1K Set Limit 1	810/1600/810	0 to 100 000
MTIE T1K Set Limit 2	1010/2000/1010	0 to 100 000
MTIE T10K Set Limit 1	880/2270/880	0 to 100 000
MTIE T10K Set Limit 2	1100/2835/1100	0 to 100 000
MTIE T100K Set Limit 1	1600/4260/1600	0 to 100 000
MTIE T100K Set Limit 2	2000/5330/2000	0 to 100 000
MTIE T10 Clear Limit 1	230/70/230	0 to 10 000
MTIE T10 Clear Limit 2	290/90/290	0 to 10 000
MTIE T100 Clear Limit 1	400/700/400	0 to 10 000
MTIE T100 Clear Limit 2	490/900/490	0 to 10 000
MTIE T1K Clear Limit 1	730/1400/730	0 to 10 000
MTIE T1K Clear Limit 2	910/1800/910	0 to 10 000
MTIE T10K Clear Limit 1	790/2000/790	0 to 10 000
MTIE T10K Clear Limit 2	990/2500/990	0 to 10 000
MTIE T100K Clear Limit 1	1440/3800/1440	0 to 10 000
MTIE T100K Clear Limit 2	1800/4800/1800	0 to 10 000
MTIE Limit 1 Alarm Mode	Minor	Ignore, Report, Minor, Major or Critical
MTIE Limit 2 Alarm Mode	Major	Ignore, Report, Minor, Major or Critical
Alarm Severity	Minor for most alarms Major for LOS	Ignore, Report, Minor, Major or Critical
Alarm Set Delay	0 seconds	0–172 800 seconds
Alarm Elevation Time	86400 seconds	0–500 000 seconds
Port Status	Disabled	Enabled/Disabled
Port Name		Any user-selected string from 0–20 characters

Japanese Composite Clock Input Module

This section provides operating instructions and software provisioning procedures for the Japanese Composite Clock Input module (part number 23413307-000-0).

Functional Overview

The Input module conditions a composite clock input signal that is used to control the frequency of the Clock modules. When the SSU-2000 is in the Subtending mode, it also produces a 4 kHz synchronization signal that determines the phase of the composite clock signals generated by Japanese Composite Clock Output modules. This signal ensures that the phase of the composite clock output signal follows the phase of the composite clock input reference signal. Refer to [Configuring a Subtending SSU](#), on page 268 for details on configuring a subtending SSU.



Note: The following version or a later version of the Buffer module, Clock module, Clock module software, and Comms module software is required for subtending mode.

- Buffer module (part number 25413122-000-0 rev A07)
 - Clock module (part number 23413015-000-0 rev A08, or 23413016-000-0 rev A09)
 - Clock module software (rev. J.00)
 - Comms module software (rev. J.00 - load 00 for standard) (rev. G.00 - load 01 for NTP)
-

If the Input module is provisioned to receive an input with a 400 Hz component and the 400 Hz is available on the input signal, the JCC4 outputs are aligned to the 400 Hz.



Note: Only Phase monitoring is available for this input type. MTIE, Frequency, and TDEV performance monitoring is not available.

The module consists of a microcontroller and firmware, SRAM for data storage, FLASH memory that contains the firmware, and other support circuitry. The module monitors and reports module status and conditions. Events are generated for Loss of Signal (LOS) and Bipolar Violation (BPV) density. Each module communicates with the Communications module to receive user configuration commands and to report status and performance for the Clock modules for frequency control.

Functional Block Diagram

A simplified block diagram of the Input module is shown in [Figure 7-11](#).

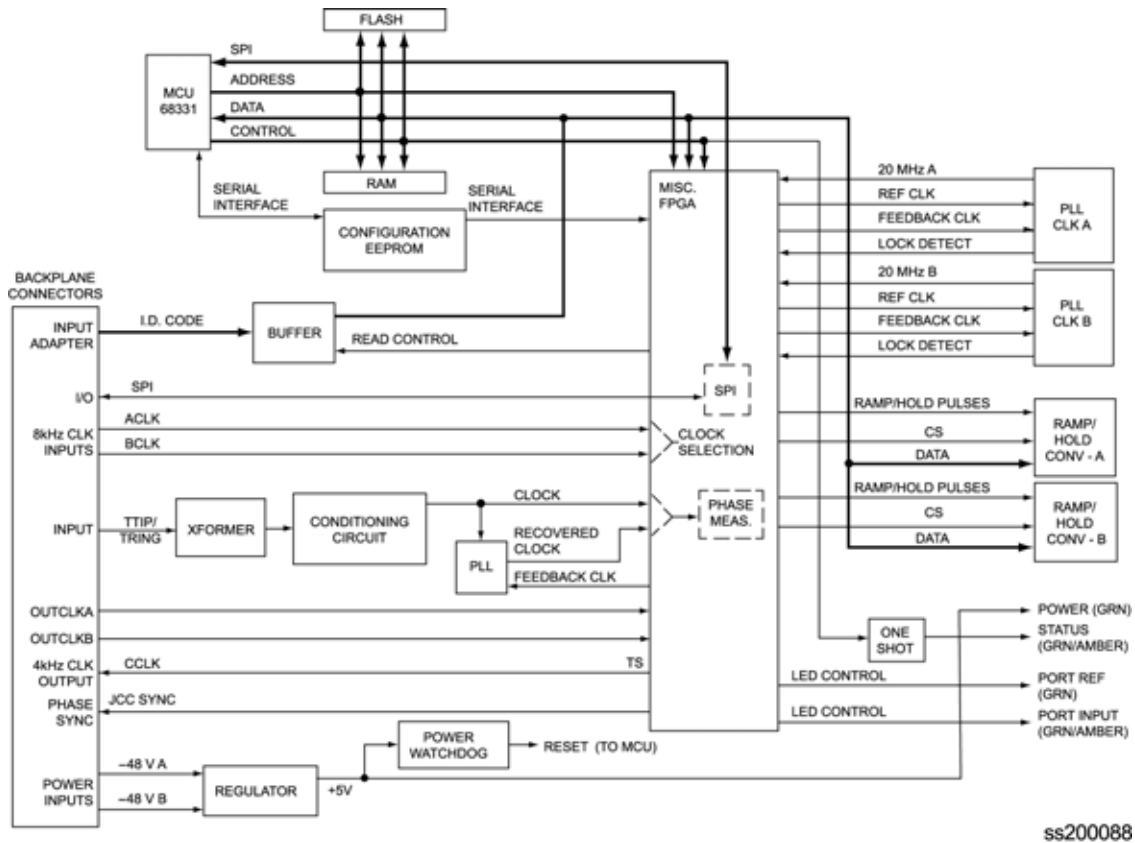

ss200088

Figure 7-11. Block Diagram of the Japanese Composite Clock Input Module

Status LED Indicators

The JCC Input module is equipped with four status LEDs as shown in [Figure 7-12](#). The LED status assignments are described in [Table 7-15](#).

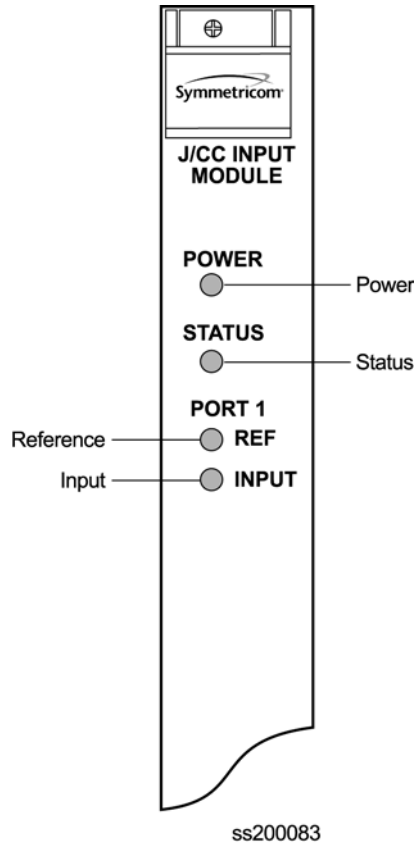

Figure 7-12. Front Panel of the Japanese Composite Clock Input Module

Table 7-15. Japanese Composite Clock Input Module Status LED Indicators

Indicator	Color	Description
POWER	Green	On = The module is receiving +5 V DC
STATUS	Green/Amber	On (Green) = Unit is in Normal mode of operation; no faults On (Amber) = Fault condition detected Blinking = Disabled or firmware upgrade in progress
REF	Green	On = Selected Reference Off = Disabled, or good and not selected
INPUT	Green/Amber	On (Green) = Enabled and signal valid On (Amber) = Enabled and signal not valid Off = Disabled

Configuration Options

The configuration settings for the Japanese CC Input module are listed in [Table 7-16](#).

Table 7-16. Japanese Composite Clock Input Module Configuration Settings

Configuration Setting	Factory Default	Range
400 Hz	ON	ON OFF
Provisioned PQL	4	1 – 16
Priority	1	1 – 10 (0 = Monitor)
Alarm Set Delay	0 seconds	0 – 172 800 seconds
Alarm Elevation Time	86400 seconds	0 – 500 000 seconds
Port Status	Disabled	Enabled Disabled
Port Name	None (blank)	Any string from 0 – 20 characters

Input Adapter Panels

This section describes the input adapters available to connect typical telecommunications signals to the rear panel of the SSU-2000 and SDU-2000.

Input Adapter Panel for 1-Port Input Module

Symmetricon offers three Input Adapter panels for use with 1-port Input modules. Each panel has the following common features:

- Accommodates up to four separate input signals
- Switch-selected inputs allow for DE9 and another connector type
- Switchable input termination impedance
- Switch-selected link between signal and frame ground (when a frame ground is connected to the lug on the rear panel)
- 1-m SCSI connection cable is included with the Adapter

The Input Adapter (part number 22013069-001-0) used with a 1-Port Input module is shown in [Figure 7-13](#). Each port has a switch-selected BNC and a DE9 connector, and the input termination impedance is switch-selectable between 50, 75, 100, 120, or 3.3 k Ω .

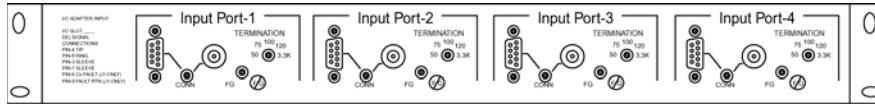

ss200019

Figure 7-13. Input I/O Adapter for One-Port Input Modules

The Input Adapter (part number 22013069-002-0) has a switch-selected Siemens 1.6/5.6 mm connector and a DE9 connector; the input termination impedance is switch-selectable between 50, 75, 100, 120, or 3.3 k Ω .

The Input Adapter (part number 22013069-003-0) has a switch-selected Siemens 1.0/2.3 mm connector and a DE9 connector; the input termination impedance is switch-selectable between 50, 75, 100, 120, or 3.3 k Ω .

The rear panel of the Input adapter contains four SCSI-II type connectors that connect to each Input module connection on the rear panel of the shelf via a supplied 1-m input cable. A frame ground lug is supplied to connect a frame ground connection.

The pinout for the DB9 connector is listed in [Table 7-17](#).

Table 7-17. Pinout for the I-Port Input Adapter

Pin	Description
3	Sleeve
4	Tip
7	Sleeve
8	Ring ¹
9	Flt Return ²

Note:

- ¹ When connected to J1 on the rear panel, Pin 8 is Cs Fault.
- ² Only when connected to J1 on the rear panel.

Input Adapter Panel for 3-Port Input Modules

Symmetricon offers four Input Adapter panels for use with 3-port Input modules. Each panel has the following common features:

- Accommodates up to three separate input signals
- Switch-selected inputs allow for DE9 and another connector type
- Switchable input termination impedance

- Switch-selected link between signal and frame ground (when a frame ground is connected to the lug on the rear panel)
- 1-m SCSI connection cable is included with the Adapter

The Input I/O Adapter (part number 22013066-001-0) used with the 3-Port Input module is shown in [Figure 7-14](#). Each port has a switch-selected BNC and a DE9 connector, and the input termination impedance is switch-selectable between 50, 75, 100, 120, or 3.3 k Ω .

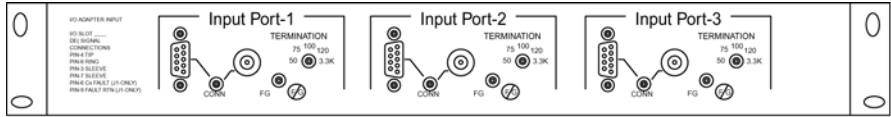

ss200018

Figure 7-14. I/O Adapter for 3-Port Input Modules

The Input Adapter (part number 22013066-002-0) has a switch-selected Siemens 1.6/5.6 mm connector and a DE9 connector; the input termination impedance is switch-selectable between 50, 75, 100, 120, or 3.3 k Ω .

The Input Adapter (part number 22013066-003-0) has a switch-selected Siemens 1.0/2.3 mm connector and a DE9 connector; the input termination impedance is switch-selectable between 50, 75, 100, 120, or 3.3 k Ω .

The Input Adapter (part number 22013315-000-2) has a switch-selected BT43 connector and a DE9 connector; the input termination impedance is switch-selectable between 50, 75, 100, 120, or 3.3 k Ω .

The rear panel of the Input adapter contains three SCSI-II type connectors that connect to each Input module connection on the rear panel of the shelf via a supplied 1-m input cable. A frame ground lug is supplied to connect a frame ground connection.

The pinout for the DB9 connector is listed in [Table 7-18](#).

Table 7-18. Pinout for the 3-Port Input Adapter

Pin	Description
3, 7	Sleeve
4	Tip
8	Ring ¹
9	Flt Return ²

Note:

¹ When connected to J1 on the rear panel, Pin 8 is Cs Fault.

² Only when connected to J1 on the rear panel.

Input Wire-Wrap Adapters

Symmetricom offers a range of input wire-wrap adapters for use with any of the SSU-2000 Input modules. [Table 7-19](#) lists the part numbers and the description for the input wire-wrap adapters, an example of which is shown in [Figure 7-15](#). These adapters connect directly to the I/O ports on the rear panel of the SSU-2000 or SDU-2000 shelf.

Table 7-19. Input Wire-Wrap Adapters

Part Number	Description
22013186-000-0	Bridging
22013186-001-0	133 Ω impedance
22013186-002-0	120 Ω impedance
22013186-003-0	100 Ω impedance
22013186-004-0	75 Ω impedance
22013186-005-0	50 Ω impedance
22013186-006-0	Port 1=110 Ω Port 2 unused, Port 3=100 Ω
22013186-007-0	Port 1=133 Ω Port 2 unused, Port 3=100 Ω

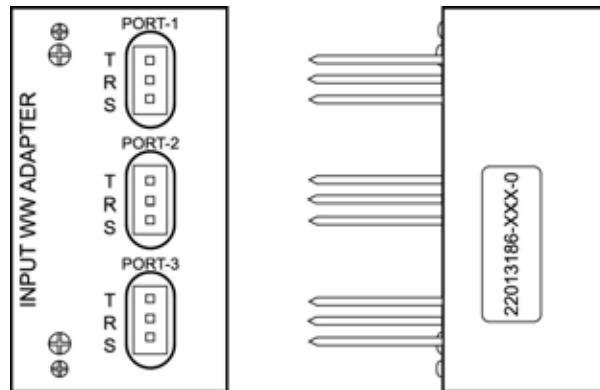

Figure 7-15. Input Wire-Wrap Adapter

Chapter 8 Output Module Reference Data

This chapter contains reference information for the Output modules available for use in the SSU-2000 and SDU-2000.

In This Chapter

- [E1 Output Module](#)
- [DS1 Output Module](#)
- [Composite Clock Output Module](#)
- [Japanese Composite Clock Output Module](#)
- [Japanese Sine Wave Output Module](#)
- [E1/2048 kHz Output Module](#)
- [2048 kHz Output Module](#)
- [RS-422 Output Module](#)
- [DS1 Line Retiming Unit \(LRU\)](#)
- [E1 Line Re-timing Unit](#)
- [Buffer Module](#)
- [Output Adapter Panels](#)

E1 Output Module

This section provides user-reference data for the E1 Output module (part number 23413018-000-0) that is used in both the SSU-2000 main shelf and in the optional SDU-2000 Expansion shelf.

Functional Overview

The E1 Output module uses one of three 4 kHz clocks from the SSU-2000 main chassis backplane to generate a phase-locked signal of 2.048 Mbps. If the unit is inserted into an SDU-2000 expansion shelf, a fourth 4kHz clock (D-clock) is available. The phase-locked 2.048 Mbps signal is used to generate a set of 20 output signals for distribution to large networks.

The output SSM can be automatically set by the input signal or manually using an ICS or TL1 command. See the *SSU-2000 Technical Reference* for details on setting the output SSM.

A microcontroller unit on the E1 Output module communicates with other boards in the main shelf and performs Output module configuration. The module's memory subsystem (EEPROM, RAM and serial EEPROM) stores the executable image, the PLD image and other configuration and temporary information for an on-module microprocessor.

The E1 Output modules may be used individually or configured for operation as redundant pairs in the shelf.

Functional Block Diagram

A simplified block diagram of the E1 Output module is shown in Figure 8-1.

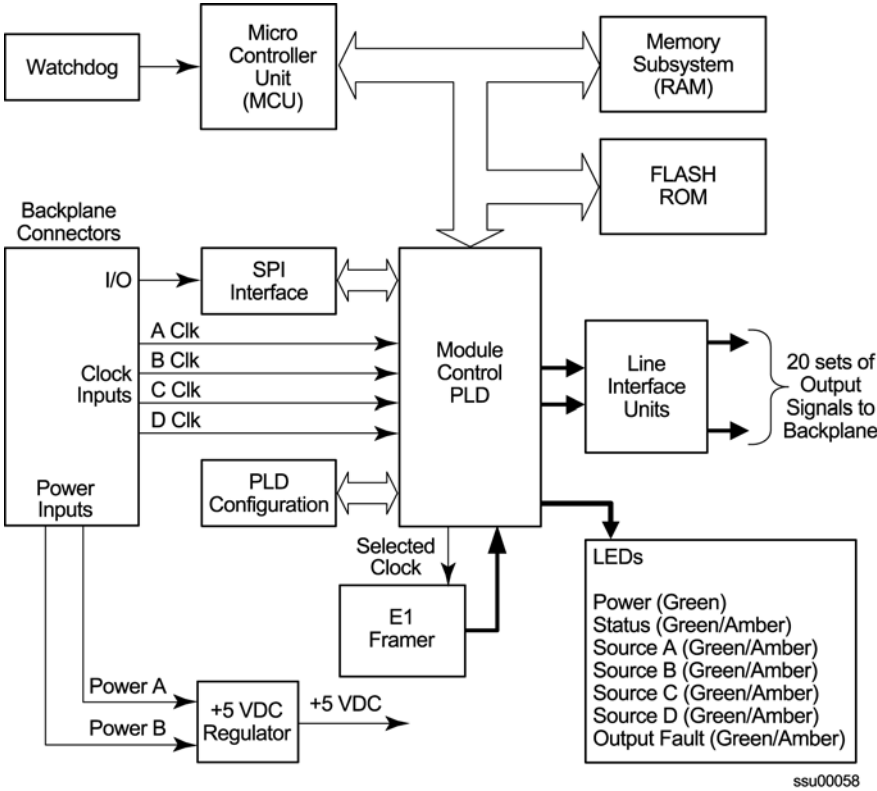

Figure 8-1. Block Diagram of the E1 Output Module

Status LED Indicators

The E1 Output module has seven status LED indicators on the front panel of the module that are used for visually conveying status information to the user. The LEDs are shown in [Figure 8-2](#) and described in [Table 8-1](#).

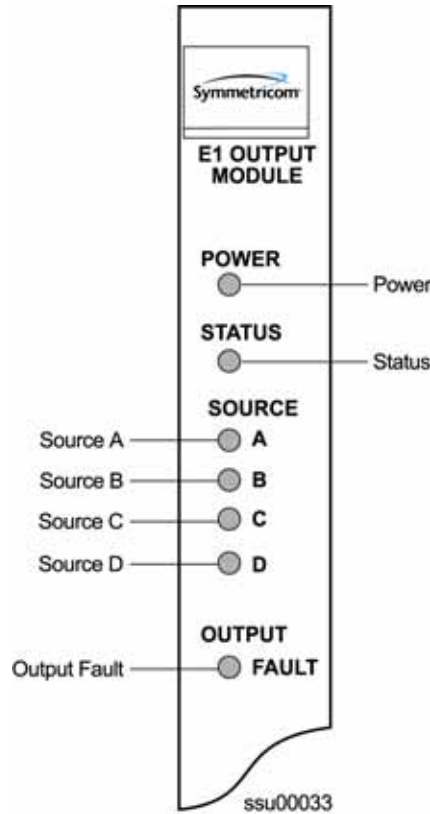

Figure 8-2. Front Panel of the E1 Output Module

Table 8-1. E1 Output Module Status LED Indicators

Indicator	Color	Description
POWER	Green	On = +5 V DC power available on the Output module
STATUS	Green/Amber	On (Green) = Module functioning correctly Blinking = Output module is disabled or downloading firmware On (Amber) = Output module failure
SOURCE A	Green/Amber	On (Green) = Clock A in slot 1 is the selected source clock On (Amber) = Faulty or missing Clock A Off = Clock A is good and not selected
SOURCE B	Green/Amber	On (Green) = Clock B in slot 12 is the selected source clock On (Amber) = Faulty or missing Clock B Off = Clock B is good and not selected

Table 8-1. E1 Output Module Status LED Indicators (Continued)

Indicator	Color	Description
SOURCE C	Green/Amber	On (Green) = The Bypass clock (Clock C) is the selected source clock. See Bypass Clock (Clock C) , on page 30 On (Amber) = Faulty or missing Bypass clock Off = Bypass clock is ignored, or good and not selected
SOURCE D	Green/Amber	On (Green) = The Expansion clock (Clock D) is the selected source clock. The module is in an Expansion shelf On (Amber) = Faulty or missing Expansion clock Off = Expansion clock is ignored, or good and not selected
OUTPUT FAULT	Amber	On = Module has detected one or more faulty outputs Off = All output signals are good

Performance Specifications

The E1 Output Module performance specifications are provided in [Table 8-2](#).

Table 8-2. E1 Output Module Performance Specifications

Performance Characteristic	Specification
Signal	Alternate Mark Inversion (AMI)
Waveshape	Per ITU-T CC (10/98)
Rise time	<100 ns
Pulse Width	244 ns, nominal into 120Ω
Pulse Interval	488 ns, nominal
Duty Cycle	50%
Pulse Amplitude	2.2 to 3.3 Vpp
Jitter	< 0.01 UI
Number of Outputs	20

DS1 Output Module

This section provides user-reference data for the DS1 Output module (part number 23413017-000-0) used in both the SSU-2000 main shelf and in the optional SDU-2000 Expansion shelf.

Functional Overview

The DS1 Output module generates a phase-locked signal of 1.544 MHz using one of three 4 kHz clocks from the backplane of the SSU-2000 main shelf (A, B, and, C clocks). If the module is inserted into the SDU-2000 Synchronization Distribution Unit (expansion shelf), a fourth 4 kHz clock (D clock) is available. The phase-locked signal generates a set of 20 output signals for distribution to large networks. A simplified block diagram of the DS1 Output module is shown in [Figure 8-3](#).

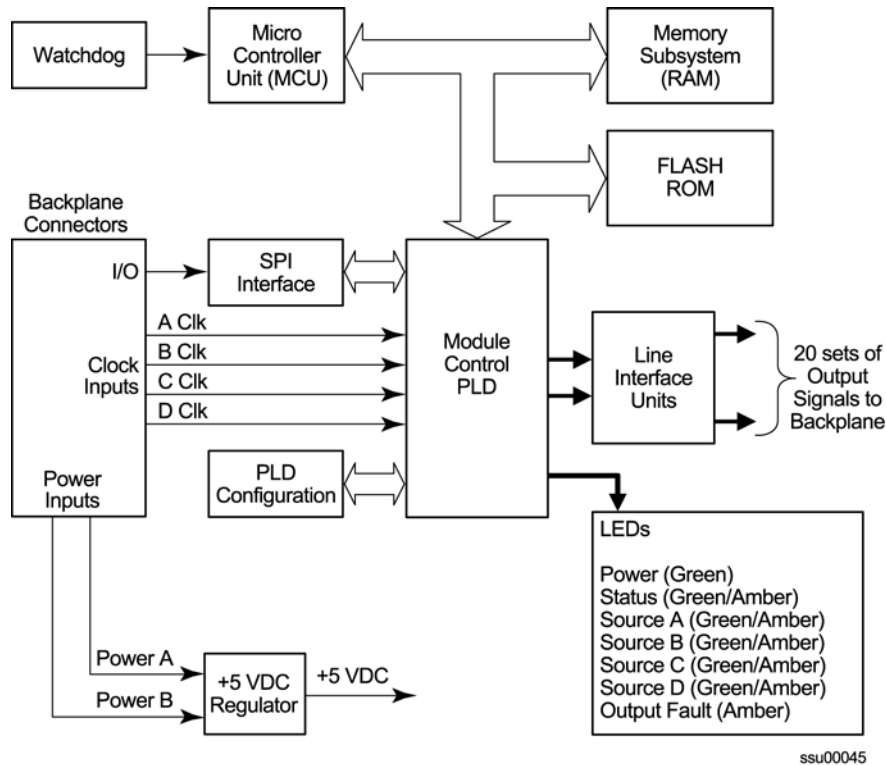

Figure 8-3. Block Diagram of the DS1 Output Module

The output SSM can be automatically set by the input signal or manually using an ICS or TL1 command. See the *SSU-2000 Technical Reference* for details on setting the output SSM.

A microcontroller unit on the DS1 Output module communicates with other boards in the main shelf and performs Output module configuration. The module's memory subsystem (EEPROM, RAM and serial EEPROM) stores the executable image, the PLD image and other configuration and temporary information for an on-module microprocessor.

The DS1 Output modules may be used individually or configured for operation as redundant pairs in the shelf.

Status LED Indicators

The DS1 Output module status LED indicators are shown in [Figure 8-4](#) and are described in [Table 8-3](#).

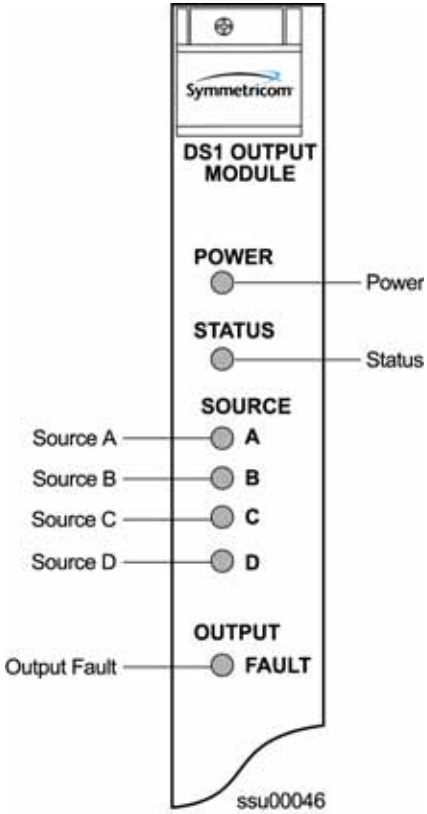

Figure 8-4. Front Panel of the DS1 Output Module

Table 8-3. DS1 Output Module Status LED Indicators

Indicator	Color	Description
POWER	Green	On = +5 V DC power available on the Output module
STATUS	Green/Amber	On (Green) = Module functioning correctly Blinking = Output module is disabled or downloading firmware On (Amber) = Output module failure

Table 8-3. DS1 Output Module Status LED Indicators (Continued)

Indicator	Color	Description
SOURCE A	Green/Amber	On (Green) = Clock A in slot 1 is the selected source clock On (Amber) = Faulty or missing Clock A Off = Clock A is good and not selected
SOURCE B	Green/Amber	On (Green) = Clock B in slot 12 is the selected source clock On (Amber) = Faulty or missing Clock B Off = Clock B is good and not selected
SOURCE C	Green/Amber	On (Green) = The Bypass clock (Clock C) is the selected source clock. See Bypass Clock (Clock C) , on page 30 On (Amber) = Faulty or missing Bypass clock Off = Bypass clock is ignored, or good and not selected
SOURCE D	Green/Amber	On (Green) = The Expansion clock (Clock D) is the selected source clock. The module is in an Expansion shelf On (Amber) = Faulty or missing Expansion clock Off = Expansion clock is ignored, or good and not selected
OUTPUT FAULT	Amber	On = Module has detected one or more faulty outputs Off = All output signals are good

Performance Specifications

The DS1 Output module specifications are provided in [Table 8-4](#).

Table 8-4. DS1 Output Module Performance Specifications

Performance Characteristic	Specification
Signal	Alternate Mark Inversion (AMI)
Waveshape	Per (ANSI) T1.102 and ITU Rec. G.703
Rise time	<100 ns
Pulse Width	324 ns, nominal into 100Ω
Pulse Interval	648 ns, nominal
Duty Cycle	50%
Pulse Amplitude	2.4 to 3.6 Vpp
Jitter	< 0.01 UI

Composite Clock Output Module

This section provides reference data for the Composite Clock Output module (part number 23413158-000-0) used in both the SSU-2000 main shelf and in the optional SDU-2000 Expansion shelf.

Functional Overview

The Composite Clock Output module generates 20 signal pairs (TTIP and TRING signal pairs). Each output is a transformer-coupled symmetrical pair. Each output pair can be turned off independently of other channels; relays on each output allow for disconnecting the driver output from the output pins. These outputs are independently configurable for duty cycle (50/50 or 62.5/37.5) and phase delay from 0 to 3.4 μ s in 8 or more steps. Refer to [Changing Factory Defaults](#), on page 113, for more information on duty cycle settings.

The outputs are byte and polarity phase aligned with the selected 4 kHz clock. Each output signal is monitored for a failed output on an independent basis. An output is said to be failed when either the polarity pulse falls below 2.1 volts base to peak, when polarity reversal can no longer be detected, or when return to zero cannot be detected.

The outputs of the Composite Clock Output module meet the criteria set forth in Bellcore GR-378-CORE and TR-TSY-000458 for signal type, amplitude, and waveshape. ITU-T Rec. G.703 Centralized Clock is partially supported (50/50 duty cycle) except only the Bellcore signal levels are generated.



Note: External, customer-supplied padding can be affixed to attenuate the output level to meet Composite Clock specifications.

Functional Block Diagram

A simplified block diagram of the Composite Clock Output module is shown in [Figure .](#)

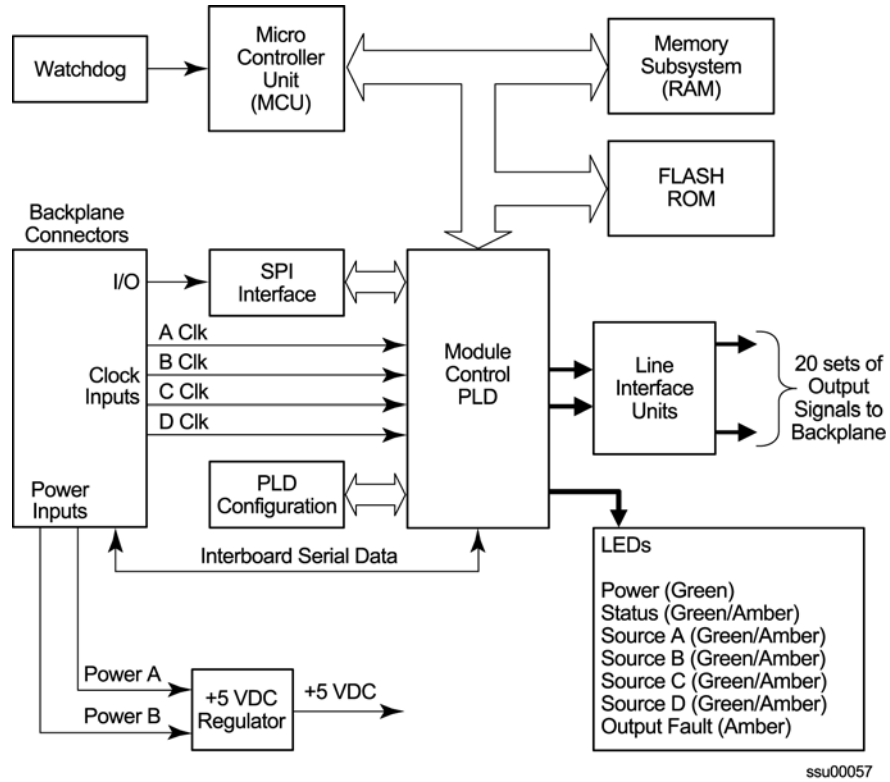

ssu00057

Figure 8-5. Block Diagram of the Composite Clock Output Module

Status LED Indicators

The Composite Clock Output module status LED indicators are shown in [Figure 8-6](#) and described in [Table 8-5](#).

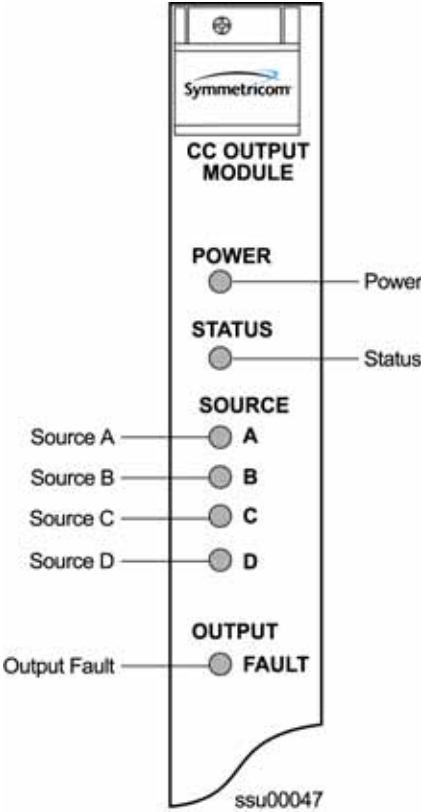

Figure 8-6. Front Panel of the Composite Clock Output Module

Table 8-5. Composite Clock Output Module Status LED Indicators

Indicator	Color	Description
POWER	Green	On = +5 V DC power available on the Output module
STATUS	Green/Amber	On (Green) = Module functioning correctly Blinking = Output module is disabled or downloading firmware On (Amber) = Output module failure
SOURCE A	Green/Amber	On (Green) = Clock A in slot 1 is the selected source clock On (Amber) = Faulty or missing Clock A Off = Clock A is good and not selected
SOURCE B	Green/Amber	On (Green) = Clock B in slot 12 is the selected source clock On (Amber) = Faulty or missing Clock B Off = Clock B is good and not selected

Table 8-5. Composite Clock Output Module Status LED Indicators (Continued)

Indicator	Color	Description
SOURCE C	Green/Amber	On (Green) = The Bypass clock (Clock C) is the selected source clock. See Bypass Clock (Clock C) , on page 30 On (Amber) = Faulty or missing Bypass clock Off = Bypass clock is ignored, or good and not selected
SOURCE D	Green/Amber	On (Green) = The Expansion clock (Clock D) is the selected source clock. The module is in an Expansion shelf On (Amber) = Faulty or missing Expansion clock Off = Expansion clock is ignored, or good and not selected
OUTPUT FAULT	Amber	On = Module has detected one or more faulty outputs Off = All output signals are good

Performance Specifications

The performance specifications for the Composite Clock Output module are provided in [Table 8-6](#).

Table 8-6. Composite Clock Output Module Performance Specifications

Performance Characteristic	Specification
Signal	Bipolar, Return to Zero, Alternate Mark Inversion (AMI)
Waveshape	Per Bellcore GR-378-CORE Table 6-2 and Figure 6-1
Rise/Fall time	<500 ns
Pulse Width	9.8 μ s \pm 2% for 62.5/37.5 duty cycle 7.8 μ s \pm 2% for 50/50 duty cycle
Pulse Interval	15.6 μ s, nominal
Duty Cycle	62.5/37.5 or 50/50 selectable
Pulse Amplitude	2.7 to 5.5 Vpk, 3.5 Vpk nominal into 133 Ω
Number of Outputs	20 Independent Channels

Japanese Composite Clock Output Module

This section provides reference data for the Japanese Composite Clock Output module (part number 23413306-000-0) used in both the SSU-2000 main shelf and in the optional SDU-2000 Expansion shelf.

Functional Overview

The Output module generates 20 non-summable signal pairs (TTIP and TRING signal pairs). Each output is a transformer-coupled symmetrical pair. Each output pair can be turned off independently of other channels. These outputs are independently configurable for phase delay from 0 to 3.4 μ s in 8 steps. Refer to [Changing Factory Defaults](#), on page 113 for more information on duty cycle settings.

A squelch feature allows you to selectively turn off (squelch) the outputs during periods of degraded performance. The output is squelched when the system priority quality level (PQL) is larger (of lower quality) than the provisioned Squelch PQL.

In Subtending mode, the Output module's signals are byte and polarity phase aligned with the 4 kHz clock signal from the Japanese Composite Clock Input module. This 4 kHz clock signal ensures that the phase of the composite clock output signal follows the phase of the composite clock input reference signal. Refer to [Configuring a Subtending SSU](#), on page 268 for details on configuring a subtending SSU.

When provisioned properly, the output aligns to the 400 Hz BPV component.



Note: The following version or a later version of the Buffer module, Clock module, Clock module software, and Comms module software is required for subtending mode.

- Buffer module (part number 25413122-000-0 rev A07)
 - Clock module (part number 23413015-000-0 rev A08, or 23413016-000-0 rev A09)
 - Clock module software (rev. J.00)
 - Comms module software (rev. J.00 - load 00 for standard) (rev. G.00 - load 01 for NTP)
-

Each output signal is monitored for a failed output on an independent basis. An output is said to be failed when either the polarity pulse falls below approximately 0.6 volt base to peak, when polarity reversal can no longer be detected, or when return to zero cannot be detected.

The outputs of the module meet the criteria set forth in the document ITU-T Rec. G.703 Appendix II.1.

Functional Block Diagram

A simplified block diagram of the Japanese CC Output module is shown in [Figure 8-7](#).

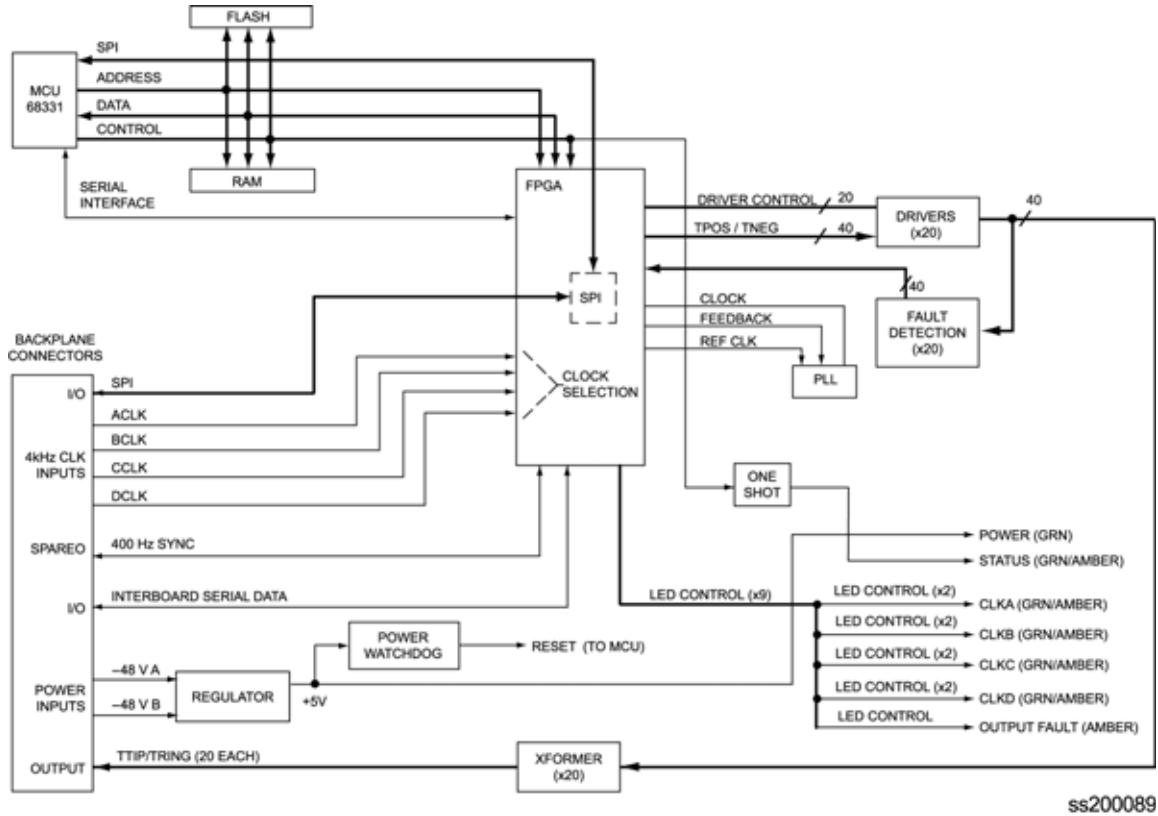

Figure 8-7. Block Diagram of the Japanese Composite Clock Output Module

Status LED Indicators

The Output module status LED indicators are shown in [Figure 8-8](#) and described in [Table 8-7](#).

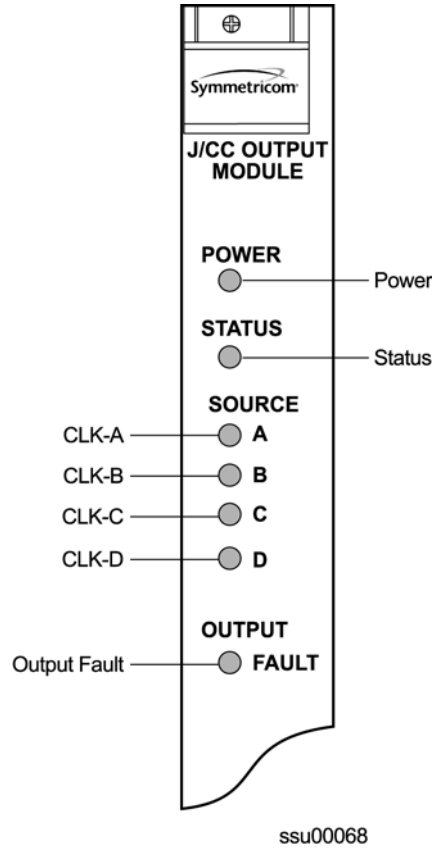

Figure 8-8. Front Panel of the Japanese Composite Clock Output Module

Table 8-7. Japanese Composite Clock Output Module Status LED Indicators

Indicator	Color	Description
POWER	Green	On = +5 VDC power available on the Output module
STATUS	Green/Amber	On (Green) = Module functioning correctly Blinking = Output module is disabled or downloading firmware On (Amber) = Output module failure
SOURCE A	Green/Amber	On (Green) = Clock A in slot 1 is the selected source clock On (Amber) = Faulty or missing Clock A Off = Clock A is good and not selected
SOURCE B	Green/Amber	On (Green) = Clock B in slot 12 is the selected source clock On (Amber) = Faulty or missing Clock B Off = Clock B is good and not selected

Table 8-7. Japanese Composite Clock Output Module Status LED Indicators (Continued)

Indicator	Color	Description
SOURCE C	Green/Amber	On (Green) = The Bypass clock (Clock C) is the selected source clock. On (Amber) = Faulty or missing Bypass clock Off = Bypass clock is ignored, or good and not selected
SOURCE D	Green/Amber	On (Green) = The Expansion clock (Clock D) is the selected source clock. The module is in an Expansion shelf On (Amber) = Faulty or missing Expansion clock Off = Expansion clock is ignored, or good and not selected
OUTPUT FAULT	Amber	On = Module has detected one or more faulty outputs Off = All output signals are good

Configuration Options

The configuration settings for the JCC Output module are listed in [Table 8-8](#).

Table 8-8. Japanese Composite Clock Output Module Configuration Settings

Configuration Setting	Factory Default	Range
Port Output (Per Port)	Enable	Enable Disable
Bypass	Enable	Enable Disable
Operating Mode	Normal (SSU)	Normal Japanese Subtending
JCC4 (400 Hz) Sync	Enable	Enable Disable
Port Delay	3 (1375 feet) in Normal mode, 7 (275 feet) in Subtending mode	0 to 7 (2200, 1925, 1650, 1375, 1100, 825, 550, and 275 feet)
Port Label (Per Port)	Null	0 – 20 ASCII printable characters.
Alarm Elevation	86400 seconds	60 – 500,000 seconds 0 is disabled

Japanese Sine Wave Output Module

This section describes the Japanese Sine Wave Output module (part number 23413304-000-0). It provides details on operation, configuration, provisioning settings, and specifications.

Functional Overview

The Output module uses one of three 4 kHz clocks from the SSU-2000 main chassis backplane to generate a phase-locked reference signal for the synchronized clock output signals. If the unit is inserted into an SDU-2000 expansion shelf, a fourth 4 kHz clock (D-clock) is available. The phase-locked signal is used to generate 20 software selectable outputs of either 6.312 MHz or 1.544 MHz for distribution to large networks.

The 20 sets of signal pairs, TTIP and TRING, represent a transformer-coupled symmetrical pair. Each output can be turned on/off independently of other channels. Each output signal is monitored for a failed output on an independent basis.

Functional Block Diagram

A simplified block diagram of the Output module is shown in [Figure 8-9](#).

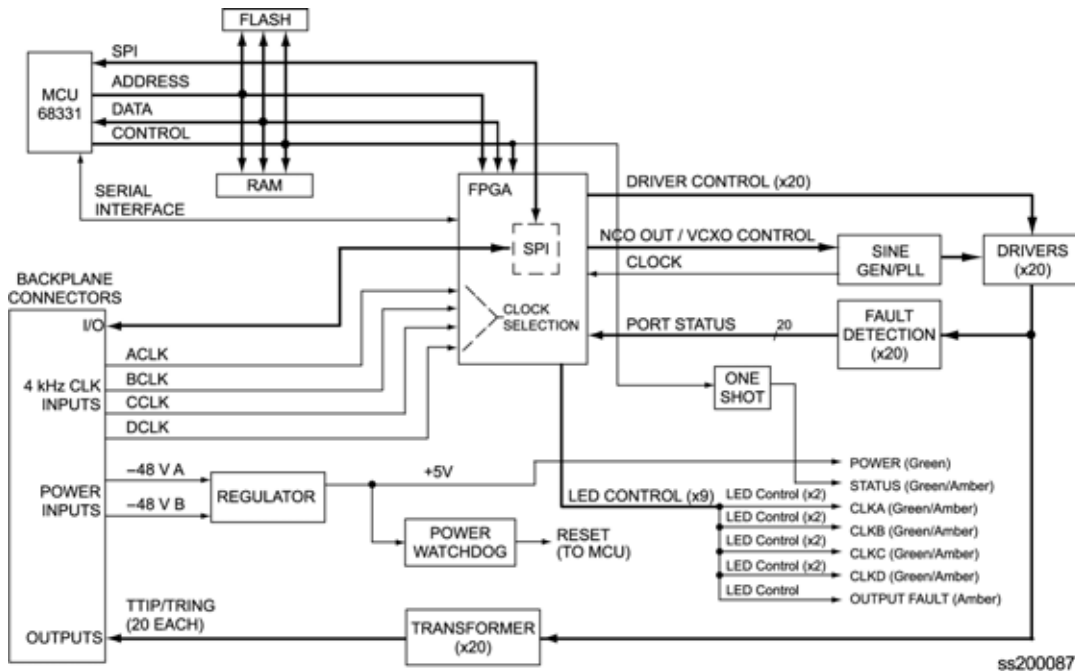

Figure 8-9. Block Diagram of the Japanese Sine Wave Output Module

When the system PQL transitions to a PQL that crosses the user-defined Output-Squelching PQL threshold, the SSU generates the assigned alarm level. The alarm message for Squelch indicates which port(s) are in alarm due to the PQL threshold being crossed. In the example Alarm message below, Port 20 of the Japanese Sine Wave Output module is in alarm.

2004-06-12T10:25:26 2A10 Maj Squelch, Below Prov, 00001

A five-digit hexadecimal number (consisting of 20 bits) at the end of the alarm message identifies the affected port(s). Each digit represents four of the 20 ports on the module; the first digit represents ports 1 through 4, the second digit represents ports 5 through 8, and so on, as shown in [Figure 8-10](#).

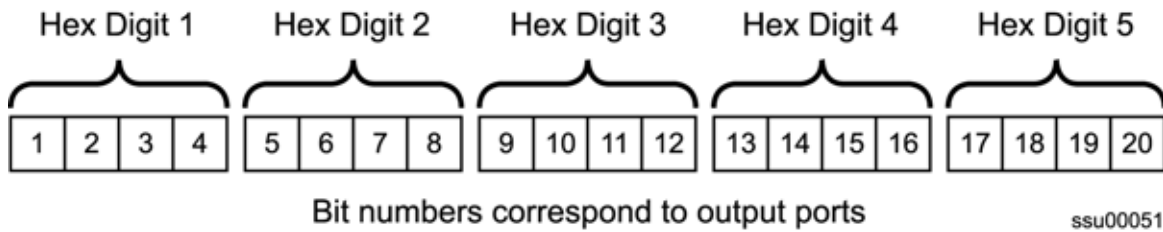

Figure 8-10. Using the Hex Number to Identify Output Ports

[Table 8-9](#) lists the failed output port number(s) for each possible hex digit. In the above alarm message, the hex number is 00001. To determine the port in alarm, locate the second row (corresponding to Hex Value 1) in [Table 8-9](#). The right-most column has an X, which corresponds to Port 20 (read across from Digit 5).

As another example, if the hex number is A501F, then the following ports are squelched: 1 and 3 (corresponding to the A in Digit 1), 6 and 8 (corresponding to the 5 in Digit 2), 16 (corresponding to the 1 in Digit 4), and 17 through 20 (corresponding to the F in Digit 5).

Table 8-9. Identifying Failed Ports From The Hex Digit

Hex Value	Port	Port	Port	Port
Digit 1	1	2	3	4
Digit 2	5	6	7	8
Digit 3	9	10	11	12
Digit 4	13	14	15	16
Digit 5	17	18	19	20
0	–	–	–	–
1	–	–	–	X
2	–	–	X	–
3	–	–	X	X
4	–	X	–	–
5	–	X	–	X

Table 8-9. Identifying Failed Ports From The Hex Digit (Continued)

Hex Value	Port	Port	Port	Port
Digit 1	1	2	3	4
Digit 2	5	6	7	8
Digit 3	9	10	11	12
Digit 4	13	14	15	16
Digit 5	17	18	19	20
6	–	X	X	–
7	–	X	X	X
8	X	–	–	–
9	X	–	–	X
A	X	–	X	–
B	X	–	X	X
C	X	X	–	–
D	X	X	–	X
E	X	X	X	–
F	X	X	X	X

Use the Alarm command to display the alarm information for a given module; the display includes all Output module alarms, including Alarm #10, Squelching. Use the ICS ALARM command or the TL1 SET-PRMTR-ALARM command to provision these alarms to Ignore, Report Only, Minor Alarm, Major Alarm (default), or a Critical Alarm.

```
SSU2000>alarm 2a10
2004-06-04T10:25:31 ID: SSU2000 Name: SSU2000
Output # Alarm Status Level(*=Elev) Ports
-----
1A06 (00) Hdw Config Ok Major
1A06 (01) Configuration Ok Major
1A06 (02) Clk-A Ok Major
1A06 (03) Clk-B Ok Major
1A06 (04) Clk-C Ok Major
1A06 (05) Clk-D Ok Major
1A06 (06) Clk Selected Ok Major
1A06 (07) VCXO Ok Major
1A06 (08) PLL Ok Major
1A06 (09) Sync Ok Major
1A06 (10) Squelch Ok Major
1A06 (11) PortFlt Ok Major
```

Status LED Indicators

The Japanese Sine Wave Output module status LED indicators are shown in [Figure 8-11](#) and described in [Table 8-10](#)

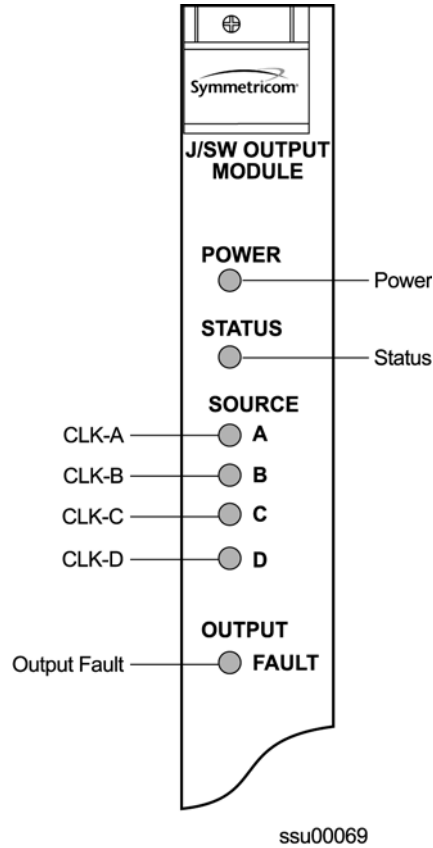

Figure 8-11. Front Panel of the Japanese Sine Wave Output Module

Table 8-10. Japanese Sine Wave Output Module Status LED Indicators

Indicator	Color	Description
POWER	Green	On = +5 V DC power available on the Output module
STATUS	Green/Amber	On (Green) = Output module functioning correctly Blinking = Output module is disabled or downloading firmware On (Amber) = Output module failure
SOURCE A	Green/Amber	On (Green) = Clock A in slot 1 is the selected source clock On (Amber) = Faulty or missing A source clock Off = Source A is good and not selected
SOURCE B	Green/Amber	On (Green) = Clock B in slot 12 is the selected source clock On (Amber) = Faulty or missing B source clock Off = Source B is good and not selected

Table 8-10. Japanese Sine Wave Output Module Status LED Indicators (Continued)

Indicator	Color	Description
SOURCE C	Green/Amber	On (Green) = The Bypass clock (Clock C) is the selected source clock On (Amber) = Faulty or missing source C clock Off = Source C is ignored, or good and not selected
SOURCE D	Green/Amber	On (Green) = The Expansion clock (Clock D) is the selected source clock. The module is in an Expansion shelf On (Amber) = Faulty or missing source D clock Off = Source D is good and not selected
OUTPUT FAULT	Amber	On = Module has detected one or more faulty outputs Off = All output signals are good

Configuration Options

Table 8-11 lists the Sine Output module configuration and default settings.

Table 8-11. Japanese Sine Wave Output Module Configuration Data

Setting	Default	Range
Frequency (Per Module)	6.312	1.544 6.312
Port Output (Per Port)	Enable	Enable Disable
Bypass	Enable	Enable Disable
Port Label (Per Port)	Null	0 – 20 ASCII printable characters
Alarm Elevation	86400 seconds	60 – 500,000 seconds 0 is disabled
Squelching (Per Port)	0	1 – 16 0 is disabled

E1/2048 kHz Output Module

This section provides reference data for the E1/2048 kHz Output module (part number 23413292-000-0) designed for use in the SSU-2000 Synchronization Supply Unit.

Functional Overview

The E1/2048 kHz Output module generates 20 outputs that are software-selectable for either E1 or 2048 kHz output signals. Each output port can be turned off independently of other ports; relays on each port disconnect the driver output from the output pins. A squelch feature turns off selected ports when the system PQL falls below predetermined quality levels.

The E1 signal has a multiframe format, with selectable Channel Associated Signaling (CAS) or Common Channel Signalling (CCS); CRC4 can be turned on or off. These default settings do not affect functionality. The Synchronization Status Message (SSM) can be turned on or off, and the bit position can be set to 4, 5, 6, 7, or 8 of time slot 0 of the odd frames. Zero suppression can be turned on or off as required. When zero suppression is off, the signal has Alternate Mark Inversion (AMI) encoding. When zero suppression is on, HDB3 encoding is used.

The output SSM can be automatically set by the input signal or manually using an ICS or TL1 command. See the *SSU-2000 Technical Reference* for details on setting the output SSM.

Provisioning the Signal Type

You use software commands to set the signal type on each port of the E1/2048 kHz Output module. To view or provision the output frequency using ICS commands, see the OUTPUT command description in the *SSU-2000 Technical Reference*.

To view the output frequency setting, use the TL1 command `RTRV-PRMTR-OUTE12048`, described in the *SSU-2000 Technical Reference*. To provision the output parameters, use the TL1 command `SET-PRMTR-OUTE12048`, described in the *SSU-2000 Technical Reference*.

Output Squelching

The E1/2048 kHz Output module allows you to selectively turn off (squelch) the outputs during periods of degraded performance.

This feature allows you to turn off any of the 20 output ports on redundant or non-redundant modules. The SSU-2000 uses the system Priority Quality Level (PQL) to determine when the system is operating within specified limits; if the outputs become degraded, the module automatically turns off the assigned ports.

To enable the squelching feature, you must provision a “threshold” PQL value using the OUTPUT command (for ICS mode) or the SET-PRMTR-OUTE12048 command (for TL1 mode). A threshold PQL value of zero disables the squelch function. Threshold PQL values above zero enable the squelch function; when the system PQL is greater than the threshold PQL, the output is squelched.

For example, you can provision output ports 1 through 5 for a threshold PQL of 3 and you can disable squelching for ports 6 through 20 (PQL is set to 0). In this example, if the system PQL is 1, 2, or 3, ports 1 through 20 generate outputs. If the system PQL changes to 4 or higher, outputs on ports 1 through 5 are squelched (turned off) and ports 6 through 20 continue to generate outputs. The response from the Output Status command appears as shown below:

```
Copyright 1997-2005, Symmetricom
SSU_2000->out 2A10
2005-09-06T19:43:03Z ID: SSU2000, Name: SSU_2000
Module Name: Output E1/2048
OUT STATUS      Clk Clk Stat          Port Status      1 1 1 1 1 1 1 1 1 2
Loc# Type  Sta Sel  A B C D Redt PQL  1 2 3 4 5 6 7 8 9 0 1 2 3 4 5 6 7 8 9 0
-----
2A10 E12M Ok  B   / / / /           4   / / / / / / / / / / / / / / / / / / / / / /

OUTPUT SETUP      ----- E1 -----
Loc# Type  Bypass ZS  SIG CRC SSM BIT
-----
2A10 E12M On      On  CAS On  On  8
Signal:
P[ 1]=  E1, P[ 2]=  E1, P[ 3]=  E1, P[ 4]=  E1, P[ 5]=  E1,
P[ 6]=  E1, P[ 7]=  E1, P[ 8]=  E1, P[ 9]=  E1, P[10]=  E1,
P[11]=  E1, P[12]=  E1, P[13]=  E1, P[14]=  E1, P[15]=  E1,
P[16]=  E1, P[17]=  E1, P[18]=  E1, P[19]=  E1, P[20]=  E1,
Squelch:
P[ 1]=  0, P[ 2]=  0, P[ 3]=  0, P[ 4]=  0, P[ 5]=  0,
P[ 6]=  0, P[ 7]=  0, P[ 8]=  0, P[ 9]=  0, P[10]=  0,
P[11]=  0, P[12]=  0, P[13]=  0, P[14]=  0, P[15]=  0,
P[16]=  0, P[17]=  0, P[18]=  0, P[19]=  0, P[20]=  0,
SSU_2000->
```

When the System PQL transitions to a PQL that crosses the user-defined Output-Squelching PQL threshold, the SSU generates a major alarm. The alarm message for Squelch indicates which port(s) are in alarm due to the PQL threshold being crossed. In the example Alarm message below, Port 20 of the E1/2048 kHz Output module is in alarm.

```
2002-12-12T10:25:26 2A10 Maj Squelch, Below Prov, 00001
```

A five-digit hexadecimal number (consisting of 20 bits) at the end of the alarm message identifies the affected port(s). Each digit represents four of the 20 ports on the module; the first digit represents ports 1 through 4, the second digit represents ports 5 through 8, and so on, as shown in [Figure 8-12](#).

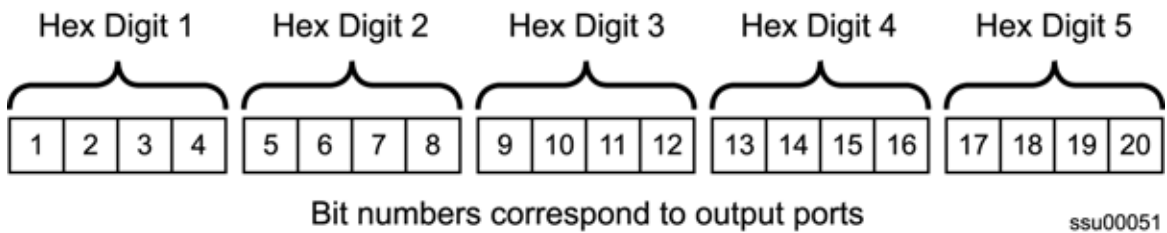

Figure 8-12. Using the Hex Number to Identify Output Ports

Table 8-12 lists the failed output port number(s) for each possible hex digit. In the above alarm message, the hex number is 00001. To determine the port in alarm, locate the second row (corresponding to Hex Value 1) in **Table 8-12**. The right-most column has an X, which corresponds to Port 20 (read across from Digit 5).

As another example, if the hex number is A501F, then the following ports are squelched: 1 and 3 (corresponding to the A in Digit 1), 6 and 8 (corresponding to the 5 in Digit 2), 16 (corresponding to the 1 in Digit 4), and 17 through 20 (corresponding to the F in Digit 5).

Table 8-12. Identifying Failed Ports from the Hex Digit

Hex Value	Port	Port	Port	Port
Digit 1	1	2	3	4
Digit 2	5	6	7	8
Digit 3	9	10	11	12
Digit 4	13	14	15	16
Digit 5	17	18	19	20
0	–	–	–	–
1	–	–	–	X
2	–	–	X	–
3	–	–	X	X
4	–	X	–	–
5	–	X	–	X
6	–	X	X	–
7	–	X	X	X
8	X	–	–	–
9	X	–	–	X
A	X	–	X	–
B	X	–	X	X
C	X	X	–	–
D	X	X	–	X
E	X	X	X	–
F	X	X	X	X

Use the Alarm command to display the alarm information for a given module; the display includes all E1/2048 kHz Output module alarms, including Alarm #10, Squelching. Use the ALARM command or the `SET-PRMTR-OUTE12048` command (described in the *SSU-2000 Technical Reference*) to provision these alarms to Ignore, Report Only, Minor Alarm, Major Alarm (default), or a Critical Alarm.

```

SSU+>a1 2a10
2002-07-04T10:25:31 ID: SSU2000 Name: SSU
Output # Alarm Status Level(*=Elev) Ports
-----
1A06 (00) Hdw Config Ok Major
1A06 (01) Configuration Ok Major
1A06 (02) Clk-A Ok Major
1A06 (03) Clk-B Ok Major
1A06 (04) Clk-C Ok Major
1A06 (05) Clk-D Ok Major
1A06 (06) Clk Selected Ok Major
1A06 (07) VCXO Ok Major
1A06 (08) PLL Ok Major
1A06 (09) Sync Ok Major
1A06 (10) Squelch Ok Major
1A06 (11) PortFlt Ok Major
SSU->

```

Provisioning the Squelch Parameter

To view or provision the squelch using ICS or TL1 commands, refer to the *SSU-2000 Technical Reference*.



Note: For ports set to E1, the frame mode is always CAS, the CRC is always enabled, and the SSM is sent to all five bit positions (4 through 8). You cannot change these settings.

Bypass Clock (Clock C) Alarms

The SSU-2000 has many configuration options. In order for the system to generate the CLK-C used by the E1/2048 kHz Output module, you must install one of the following Input modules and connect an input signal to the module: DS1, E1, or CC.

If the SSU-2000 has only GPS Input module(s), then set the Bypass mode to OFF to prevent the Output modules from generating the CLK-C alarm (alarm 4).

Output Fault Handling

When an output fault occurs, a port fault alarm occurs. Fault recovery is automatic; when the fault is no longer present, normal operation continues. To prevent “bouncing,” or reporting errors continuously, the module increments an error counter each time a port fault occurs. If the error count exceeds a preset threshold, then the faulty port is disabled. You must disable and then enable the port using software commands to return it to normal service. The error counter automatically resets when there are no errors in 24 hours.

The port status message indicates the state of each port. The letter code for each port is as follows:

- F – port fault
- N – port is disabled
- blank – port is in normal service

The following example shows port 5 with an internal port fault, port 7 with an external port fault, and ports 10, 11, and 12 disabled.

```
SSU+>out
OUT STATUS Clk Clk Stat          Port Status      1 1 1 1 1 1 1 1 1 1 2
Loc# Type Sta Sel  A B C D   Redt PQL  1 2 3 4 5 6 7 8 9 0 1 2 3 4 5 6 7 8 9 0
-----
1A06 E12M Ok  A   / / /N/N      4   / / / / /I/ /E/ / /N/N/N/ / / / / / / / / / /
```

Functional Block Diagram

A simplified block diagram of the E1/2048 kHz Output module is shown in [Figure 8-13](#).

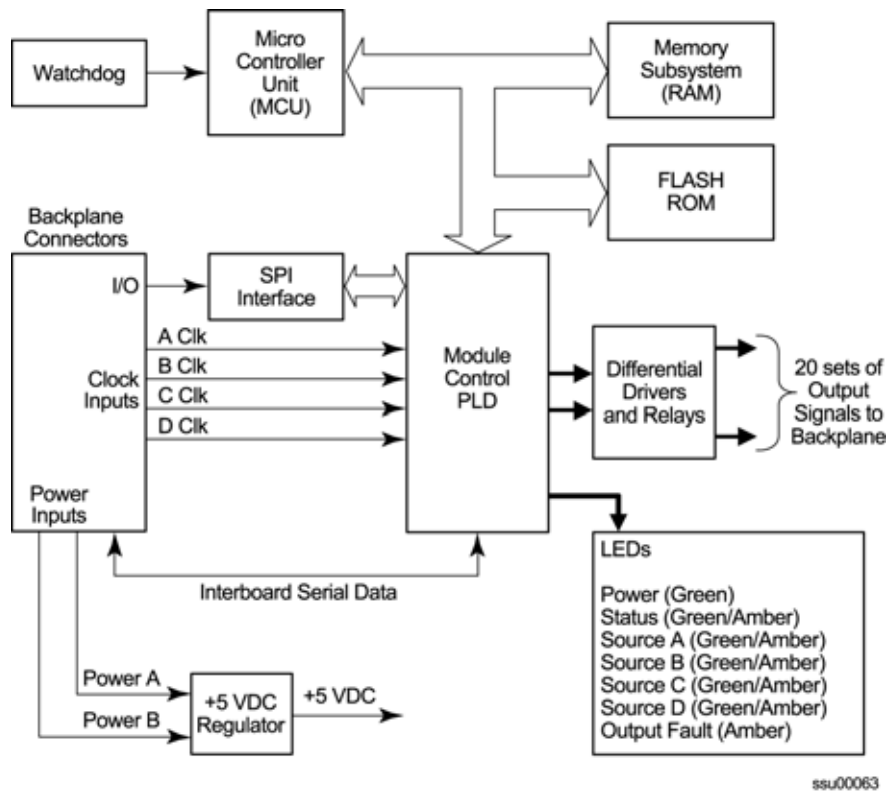

Figure 8-13. Block Diagram of the E1/2048 kHz Output Module

Status LED Indicators

The Output module status LED indicators are shown in [Figure 8-14](#) and described in [Table 8-13](#).

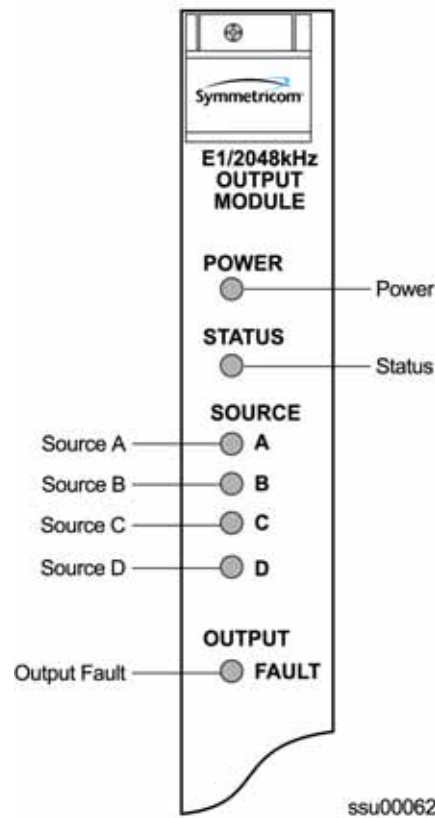

Figure 8-14. Front Panel of the E1/2048 kHz Output Module

Table 8-13. E1/2048 kHz Output Module Status LED Indicators

Indicator	Color	Description
POWER	Green	On = +5 V DC power available on the Output module
STATUS	Green/Amber	On (Green) = Output module functioning correctly Blinking = Output module is disabled or downloading firmware On (Amber) = Output module failure
SOURCE A	Green/Amber	On (Green) = Clock A in slot 1 is the selected source clock On (Amber) = Faulty or missing Clock A Off = Clock A is good and not selected
SOURCE B	Green/Amber	On (Green) = Clock B in slot 12 is the selected source clock On (Amber) = Faulty or missing Clock B Off = Clock B is good and not selected

Table 8-13. E1/2048 kHz Output Module Status LED Indicators (Continued)

Indicator	Color	Description
SOURCE C	Green/Amber	On (Green) = The Bypass clock (Clock C) is the selected source clock. See Bypass Clock (Clock C) , on page 30 On (Amber) = Faulty or missing Bypass clock Off = Bypass clock is ignored, or good and not selected
SOURCE D	Green/Amber	On (Green) = The Expansion clock (Clock D) is the selected source clock. The module is in an Expansion shelf On (Amber) = Faulty or missing Expansion clock Off = Expansion clock is ignored, or good and not selected
OUTPUT FAULT	Amber	On = Module has detected one or more faulty outputs Off = All output signals are good

E1/2048 kHz Output Signal Specifications

Specifications for the E1/2048 kHz Output signals are provided in [Table 8-14](#).

Table 8-14. E1/2048 kHz Output Module Specifications

Signal	120 Ω	75 Ω
E1		
Specification	ITU-T G.703/9 (10/98)	ITU-T G.703/9 (10/98)
Signal	AMI or HDB3	AMI or HDB3
Format	CAS or CCS	CAS or CCS
CRC	On or Off	On or Off
SSM	On or Off	ON or Off
Cable	Twisted pair, 120 Ω	Coaxial, 75 Ω
Maximum Peak Voltage	3.3 V	2.61 V
Minimum Peak Voltage	2.7 V	2.13 V
2048 kHz		
Specification	ITU-T G.703/9 (10/98)	ITU-T G.703/9 (10/98)
Signal	Clock	Clock
Format	None	None
Cable	Twisted pair, 120 Ω	Coaxial, 75 Ω
Maximum Peak Voltage	1.90 V	1.50 V
Minimum Peak Voltage	1.00V	0.75 V

2048 kHz Output Module

This section provides reference data for the 2048 kHz Output module (part number 23413159-000-0). It also contains default provisioning settings, and procedures for connecting to the SSU-2000 in order to enable, provision, and disable the module.

Functional Overview

The 2048 kHz Output module receives a set of three (four if installed in an expansion shelf) 4 kHz clocks from the Clock modules and uses these clocks to develop an 8.192 MHz phase-locked signal. This phase-locked signal is then used to generate 20 sets of 2048 kHz clock outputs.

The 20 sets of 2048 kHz signal pairs TTIP and TRING represent a transformer-coupled symmetrical pair. Each output can be turned on/off independently of other channels; relays on each output allow for disconnecting the driver output from the output pins. Each output signal is monitored for a failed output on an independent basis. An output signal is designated failed when the level falls below 0.75 volts base to peak.

In non-redundant configuration a failed output will not be turned off, as some equipment may tolerate a wide range of level and still be operating. In redundant operation a failed output will be turned off in one module at a time to try and isolate the source of the problem. The outputs meet the criteria set forth in ITU-T G.703 for signal type, amplitude, and waveshape.

Functional Block Diagram

A simplified block diagram of the 2048 kHz Output module is shown in [Figure 8-15](#).

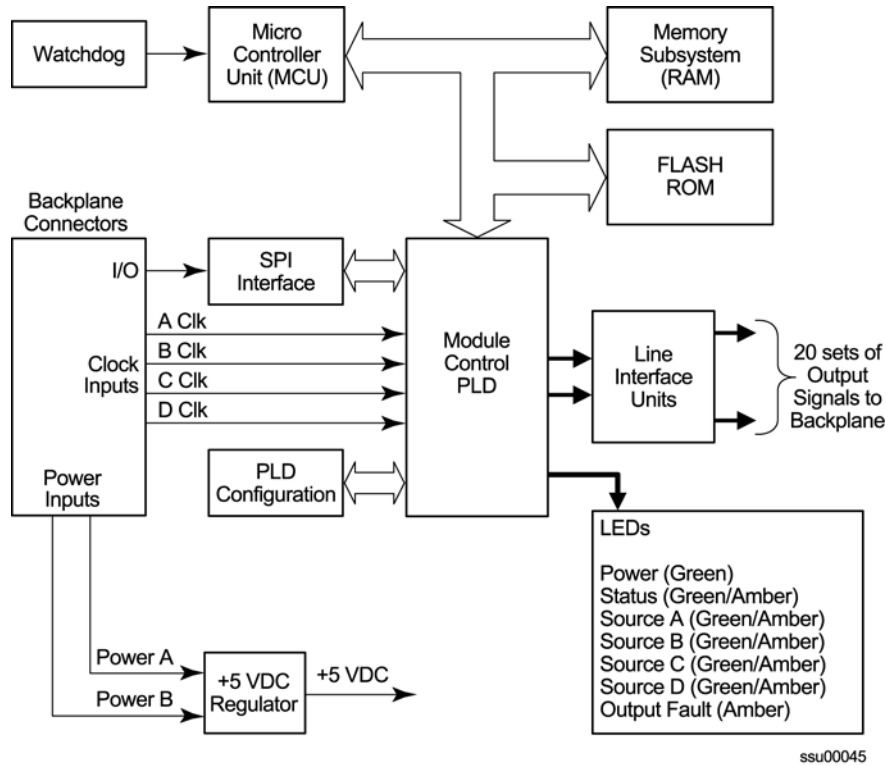

Figure 8-15. Block Diagram of the 2048 kHz Output Module

Output Squelching

A new feature, available with Revision C of the firmware for the 2048 kHz Output module, allows you to selectively turn off (squelch) the outputs during periods of degraded performance. To use this feature, the Communications module must have Revision D or later firmware.

This feature allows you to turn off any of 20 output ports on redundant or non-redundant modules. The SSU-2000 uses the system Priority Quality Level (PQL) to determine when the system is operating within specified limits; if the outputs become degraded, then the system automatically turns off the affected ports.

To enable the squelching feature, you must provision a “threshold” PQL value using the ICS OUTPUT command or the TL1 SET-PRMTR-CLKOUT command. A threshold PQL value of zero disables the squelch function. Threshold PQL values above zero enable the squelch function; when the system PQL is greater than the threshold PQL, the output is squelched.

For example, you can provision output ports 1 through 5 for a threshold PQL of 3 and you can disable squelching for ports 6 through 20 (PQL is set to 0). In this example, if the system PQL is 1, 2, or 3, then ports 1 through 20 generate 2048 kHz outputs. If the system PQL changes to 4 or higher, then outputs on ports 1 through 5 are squelched (disabled) and ports 6 through 20 continue to generate 2048 kHz outputs. The response from the Output Status command appears as shown below:

Table 8-15. Identifying Failed Ports from the Hex Digit

Hex Value	Port	Port	Port	Port
Digit 1	1	2	3	4
Digit 2	5	6	7	8
Digit 3	9	10	11	12
Digit 4	13	14	15	16
Digit 5	17	18	19	20
0	–	–	–	–
1	–	–	–	X
2	–	–	X	–
3	–	–	X	X
4	–	X	–	–
5	–	X	–	X
6	–	X	X	–
7	–	X	X	X
8	X	–	–	–
9	X	–	–	X
A	X	–	X	–
B	X	–	X	X
C	X	X	–	–
D	X	X	–	X
E	X	X	X	–
F	X	X	X	X

Use the Alarm command to display the alarm information for a given module to display all 2048 kHz Output module alarms, including Alarm #14, Squelching. Use the Alarm command to provision these alarms to be Ignored or to generate a Report Only, Minor Alarm, Major Alarm (default), or a Critical Alarm.

```
SSU+>a1 2a10
2002-12-12T10:25:31 ID: SSU2000 Name: SSU
Output # Alarm Status Level(*=Elev) Ports
-----
2A10 (00) Redundant Ok Major
2A10 (01) Module Match Ok Major
2A10 (02) Clk-A Ok Major
2A10 (03) Clk-B Ok Major
2A10 (04) Clk-C Ok Major
2A10 (05) Clk-D Ok Major
2A10 (06) Clk Level Ok Major
2A10 (07) Clk Selected Ok Major
2A10 (08) VCXO Ok Major
```

2A10	(09) PLL	Ok	Major	
2A10	(10) Configuration	Ok	Major	
2A10	(11) IntPortFlt	Ok	Major	
2A10	(13) Hdw Config	Ok	Major	
2A10	(14) Squelch Below Prov		Major	00001

SSU->

Provisioning the Squelch Parameter

To view or provision the squelch using ICS commands, see the OUTPUT command description in the *SSU-2000 Technical Reference*. To provision the squelch using TL1 commands, refer to the Set 2048 kHz Output Parameters section in the *SSU-2000 Technical Reference*.

Status LED Indicators

The Output module status LED indicators are shown in [Figure 8-17](#) and described in [Table 8-16](#).

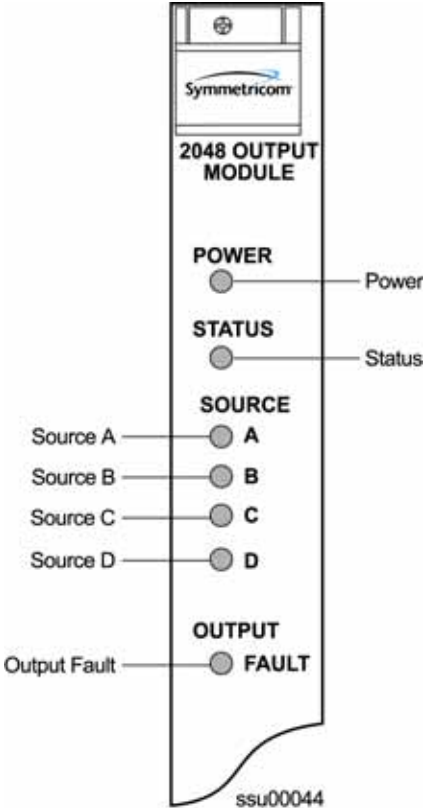

Figure 8-17. Front Panel of the 2048 kHz Output Module

Table 8-16. 2048 kHz Output Module Status LED Indicators

Indicator	Color	Description
POWER	Green	On = +5 V DC power available on the Output module
STATUS	Green/Amber	On (Green) = module functioning correctly Blinking = Output module is disabled or downloading firmware On (Amber) = Output module failure
SOURCE A	Green/Amber	On (Green) = Clock A in slot 1 is the selected source clock On (Amber) = Faulty or missing Clock A Off = Clock A is good and not selected
SOURCE B	Green/Amber	On (Green) = Clock B in slot 12 is the selected source clock On (Amber) = Faulty or missing Clock B Off = Clock B is good and not selected
SOURCE C	Green/Amber	On (Green) = The Bypass clock (Clock C) is the selected source clock. See Bypass Clock (Clock C) , on page 30 On (Amber) = Faulty or missing Bypass clock Off = Bypass clock is ignored, or good and not selected
SOURCE D	Green/Amber	On (Green) = The Expansion clock (Clock D) is the selected source clock. The module is in an Expansion shelf On (Amber) = Faulty or missing Expansion clock Off = Expansion clock is ignored, or good and not selected
OUTPUT FAULT	Amber	On = Module has detected one or more faulty outputs Off = All output signals are good

Performance Specifications

Specifications for the 2048 kHz Output module are provided in [Table 8-17](#).

Table 8-17. 2048 kHz Output Module Specifications

Performance Characteristic	Specification
Frequency	2048 kHz
Waveshape	Per ITU-T G.703 (Oct. 98) Table 11 and Figure 20
Pulse Amplitude	1.0 to 1.9 Vpk, 1.5 Vpk nominal into 120 Ω 0.75 to 1.5 Vpk, 1.0 Vpk nominal into 75 Ω
Jitter	≤ 0.01 UIpp, 20 Hz to 100 kHz
Number of Outputs	20 Independent

RS-422 Output Module

This section provides reference data for the RS-422 Output module (part number 23413287-000-0) designed for use in the SSU-2000 Synchronization Supply Unit.

Functional Overview

The RS-422 Output module generates 10 balanced square-wave outputs (TTIP and TRING signal pairs) and 10 single-ended (Ring) square-wave outputs. Each output can be turned off independently of other ports; relays on each output disconnect the driver output from the output pins. A squelch feature turns off selected ports when the input signal falls below predetermined quality levels.

You can provision the output port frequency from 8 kHz to 4096 kHz in 8 kHz increments. The frequency selected for port 1 (balanced) is also present on port 11 (single-ended); the frequency selected for port 2 determines the frequency for port 12, and so on.

The RS-422 Output module can be used individually or it can be configured for operation as redundant pairs in the shelf. When redundant modules are installed and the frequency is changed on one module, the redundant module turns its output off, changes to the new frequency and locking in phase with it, and then turns its output on again.

Functional Block Diagram

A simplified block diagram of the RS-422 Output module is shown in [Figure 8-18](#).

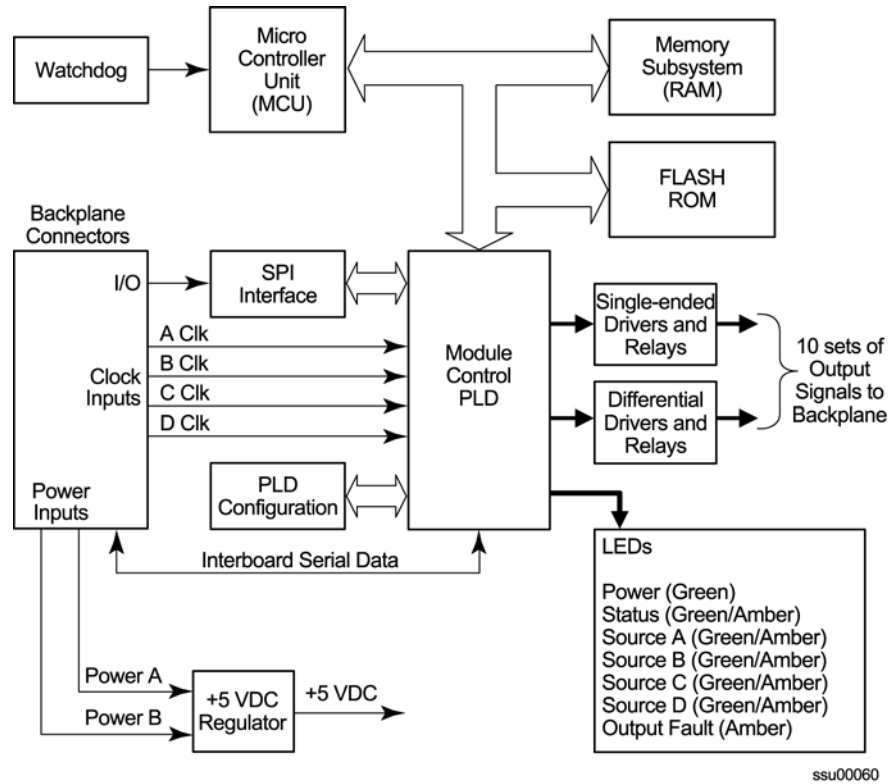

Figure 8-18. Block Diagram of the RS-422 Output Module

Provisioning Output Frequencies

You use software commands to set the frequency of each port on the RS-422 Output module. Commands are available in both ICS and TL1 modes. To provision the output frequency using ICS, see the OUTPUT command description in the *SSU-2000 Technical Reference*. The TL1 commands RTRV-PRMTR-OUT422 and SET-PRMTR-OUT422 are described in the *SSU-2000 Technical Reference*.



Note: You can set frequencies on port 1 through port 10. Port 11 follows the frequency setting of port 1. Port 12 follows the frequency setting of port 2, etc. Ports 1 and 11, 2 and 12, ..., 10 and 20 have the same frequency setting.

Output Squelching

The RS-422 Output module allows you to selectively turn off (squelch) the outputs during periods of degraded performance. To use this feature, the Communications module must have Revision D or later firmware.

This feature allows you to turn off any of 20 output ports on redundant or non-redundant modules. The SSU-2000 uses the system Priority Quality Level (PQL) to determine when the system is operating within specified limits; if the outputs become degraded, the module automatically turns off the affected ports.

To enable the squelching feature, you must provision a “threshold” PQL value using the OUTPUT command (for ICS mode) or the SET-PRMTR-CLKOUT command (for TL1 mode). A threshold PQL value of zero disables the squelch function. Threshold PQL values above zero enable the squelch function; when the system PQL is greater than the threshold PQL, the output is squelched.

For example, you can provision output ports 1 through 5 for a threshold PQL of 3 and you can disable squelching for ports 6 through 20 (PQL is set to 0). In this example, if the system PQL is 1, 2, or 3, ports 1 through 20 generate outputs. If the system PQL changes to 4 or higher, outputs on ports 1 through 5 are squelched (disabled) and ports 6 through 20 continue to generate outputs. The response from the Output Status command appears as shown below:

```
SSU->out 2a10
2003-07-04T15:30:14 ID: SSU2000 Name:SSU
Module Name: Output RS-422
OUT STATUS      Clk Clk Stat      Port Status      1 1 1 1 1 1 1 1 1 2
Loc# Type Sta Sel  A B C D Redt Pql 1 2 3 4 5 6 7 8 9 0 1 2 3 4 5 6 7 8 9 0
-----
2A10 ????? Ok  A  /Y/Y/N/Y      4  /S/S/S/S/S/ / / / / / / / / / / / / / / / /
OUTPUT SETUP
Loc# Type ZS   MinClk Bypass
-----
2A10 ????? NA  ACQ   Off
Output fault action: Leave On
Squelch Level:
P[ 1]= 3, P[ 2]= 3, P[ 3]= 3, P[ 4]= 3, P[ 5]= 3,
P[ 6]= 0, P[ 7]= 0, P[ 8]= 0, P[ 9]= 0, P[10]= 0,
P[11]= 0, P[12]= 0, P[13]= 0, P[14]= 0, P[15]= 0,
P[16]= 0, P[17]= 0, P[18]= 0, P[19]= 0, P[20]= 0,
```

When the System PQL transitions to a PQL that crosses the user-defined Output-Squelching PQL threshold, the SSU generates an alarm. The alarm message for Alarm #14, Squelch, indicates which port(s) are in alarm due to the PQL threshold being crossed. In the example Alarm message below, Port 20 of the RS-422 Output module is in alarm.

```
2002-12-12T10:25:26 2A10 Maj Squelch, Below Prov, 00001
```

A five-digit hexadecimal number (consisting of 20 bits) at the end of the alarm message identifies the affected port(s). Each digit represents four of the 20 ports on the module; the first digit represents ports 1 through 4, the second digit represents ports 5 through 8, and so on, as shown in [Figure 8-19](#).

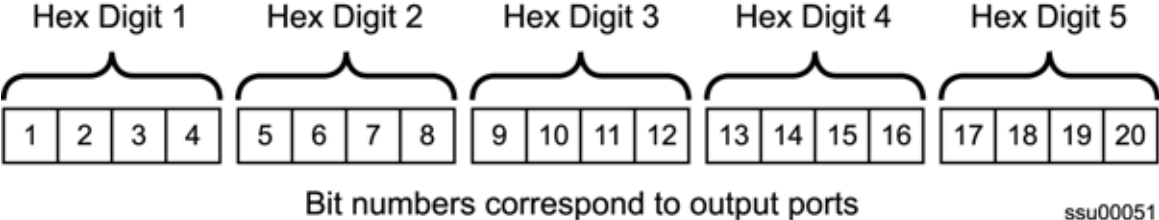

Figure 8-19. Using the Hex Number to Identify Output Ports

Table 8-18 lists the failed output port number(s) for each possible hex digit. In the above alarm message, the hex number is 00001. To determine the port in alarm, locate the second row (corresponding to Hex Value 1) in **Table 8-18**. The right-most column has an X, which corresponds to Port 20 (read across from Digit 5).

As another example, if the hex number is A501F, then the following ports are squelched: 1 and 3 (corresponding to the A in Digit 1), 6 and 8 (corresponding to the 5 in Digit 2), 16 (corresponding to the 1 in Digit 4), and 17 through 20 (corresponding to the F in Digit 5).

Table 8-18. Identifying Failed Ports from the Hex Digit

Hex Value	Port	Port	Port	Port
Digit 1	1	2	3	4
Digit 2	5	6	7	8
Digit 3	9	10	11	12
Digit 4	13	14	15	16
Digit 5	17	18	19	20
0	–	–	–	–
1	–	–	–	X
2	–	–	X	–
3	–	–	X	X
4	–	X	–	–
5	–	X	–	X
6	–	X	X	–
7	–	X	X	X
8	X	–	–	–
9	X	–	–	X
A	X	–	X	–
B	X	–	X	X
C	X	X	–	–
D	X	X	–	X
E	X	X	X	–
F	X	X	X	X

Use the Alarm command to display the alarm information for a given module; the display includes all RS-422 Output module alarms, including Alarm #14, Squelching. Use the Alarm command to provision these alarms to Ignore, Report Only, Minor Alarm, Major Alarm (default), or a Critical Alarm.

```
SSU->a1 2a10
2002-07-04T10:25:31 ID: SSU2000 Name: SSU

Output # Alarm Status Level(*=Elev) Ports
-----
2A10 (00) Hdw Config Ok Major
2A10 (01) COnfiguration Ok Major
2A10 (02) Clk-A Ok Major
2A10 (03) Clk-B Ok Major
2A10 (04) Clk-C Ok Major
2A10 (05) Clk-D Ok Major
2A10 (06) Clk Selected Ok Major
2A10 (07) VCXO Ok Major
2A10 (08) PLL Ok Major
2A10 (09) PortFlt Active Ok Major
SSU->
```

Provisioning the Squelch Parameter

To view or provision the squelch using ICS commands, see the OUTPUT command description in the *SSU-2000 Technical Reference*. To provision the squelch using TL1 commands, refer to the *SSU-2000 Technical Reference*.

Status LED Indicators

The RS-422 Output module has seven LED status indicators along the front edge of the module that are used for visually conveying status information to the user. The LEDs are shown in [Figure 8-20](#) and described in [Table 8-19](#).

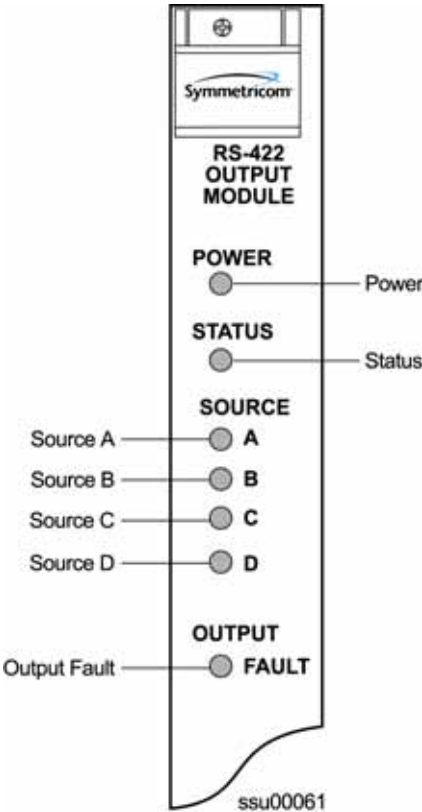

Figure 8-20. Front Panel of the RS-422 Output Module

Table 8-19. RS-422 Output Module Status LED Indicators

Indicator	Color	Description
POWER	Green	On = +5 V DC power available on the Output module
STATUS	Green/Amber	On (Green) = Output module functioning correctly Blinking = Output module is disabled or downloading firmware On (Amber) = Output module failure
SOURCE A	Green/Amber	On (Green) = Clock A in slot 1 is the selected source clock On (Amber) = Faulty or missing Clock A Off = Clock A is good and not selected
SOURCE B	Green/Amber	On (Green) = Clock B in slot 12 is the selected source clock On (Amber) = Faulty or missing Clock B Off = Clock B is good and not selected
SOURCE C	Green/Amber	On (Green) = The Bypass clock (Clock C) is the selected source clock. See Bypass Clock (Clock C) , on page 30 On (Amber) = Faulty or missing Bypass clock Off = Bypass clock is ignored, or good and not selected
SOURCE D	Green/Amber	On (Green) = The Expansion clock (Clock D) is the selected source clock. The module is in an Expansion shelf On (Amber) = Faulty or missing Expansion clock Off = Expansion clock is ignored, or good and not selected
OUTPUT FAULT	Amber	On = Module has detected one or more faulty outputs Off = All output signals are good

Performance Specifications

Specifications for the RS-422 Output module are provided in [Table 8-20](#).

Table 8-20. RS-422 Output Module Performance Specifications

Performance Characteristic	Specification
Frequency	8 kHz to 4096 kHz, in 8 kHz increments
Format/level	Ports 1–10: Per TIA/EIA-422V Ports 11–20: TTL
Waveshape	Differential square wave, 50/50 duty cycle Single-ended square wave, 50/50 duty cycle
Rise/Fall time	< 50 ns

Table 8-20. RS-422 Output Module Performance Specifications (Continued)

Performance Characteristic	Specification
Jitter	<0.03 UI up to 1.96 MHz
Number of Outputs	10 differential 10 single-ended

DS1 Line Retiming Unit (LRU)

This section provides information on the installation and operation of the DS1 Line Re-timing Unit (LRU) designed for operation in the SSU-2000 Synchronization Supply Unit and the SDU-2000 Expansion shelf. It provides a list of new TL1 and ICS commands for the LRU along with some examples of how to use the commands.

The LRU is comprised of a Line Re-timing Module (LRM) and a Cut-Through Assembly (CTA). The LRU is available in both a two-port (Dual) and four-port (Quad) version. LRU part numbers are as follows:

- Dual CTA 22013300-000-0
- Quad CTA 22013300-001-0
- Dual LRM 23413301-000-0
- Quad LRM 23413301-001-0

[Table 8-21](#) lists the LRM kits that are available. See your Symmetricom sales representative for details.

Table 8-21. LRM Kits

Kit	Contents
Dual DS1 LRU (13813302-000-0) This kit adds two retiming circuits to an existing LRU system.	1 each Dual LRM (23413301-000-0) 1 each Dual CTA (22013300-000-0) 1 each Wire-wrap label (12213299-000-1) 1 each cable 805SCSITLCO
Quad DS1 LRU (13813302-001-0) This kit adds four retiming circuits to an existing LRU system.	1 each Quad LRM (23413301-001-0) 1 each Quad CTA (22013300-001-0) 1 each Wire-wrap label (12213299-001-1) 1 each cable 805SCSITLCO
Dual DS1 LRU (13813302-002-0) This kit adds two retiming circuits; includes 19-inch rack mounting hardware.	1 each Dual LRM (23413301-000-0) 1 each Dual CTA (22013300-000-0) 1 each Wire-wrap label (12213299-000-1) 1 each cable 805SCSITLCO Wire-wrap Panel 799PE3020084 Dwg WW mod 11913299-000-2
Quad DS1 LRU (13813302-003-0) This kit adds four retiming circuits; includes 19-inch rack mounting hardware.	1 each Quad LRM (23413301-001-0) 1 each Quad CTA (22013300-001-0) 1 each Wire-wrap label (12213299-001-1) 1 each cable 805SCSITLCO Wire-wrap Panel 799PE3020084 Dwg WW mod 11913299-000-2

Table 8-21. LRM Kits (Continued)

Kit	Contents
Dual DS1 LRU (13813302-004-0) This kit adds two retiming circuits; includes 23-inch rack mounting hardware.	1 each Dual LRM (23413301-000-0) 1 each Dual CTA (22013300-000-0) 1 each Wire-wrap label (12213299-000-1) 1 each cable 805SCSITLCO Wire-wrap Panel 799PE3020081 Dwg WW mod 11913299-000-2
Quad DS1 LRU (13813302-005-0) This kit adds four retiming circuits; includes 23-inch rack mounting hardware.	1 each Quad LRM (23413301-001-0) 1 each Quad CTA (22013300-001-0) 1 each Wire-wrap label (12213299-001-1) 1 each cable 805SCSITLCO Wire-wrap Panel 799PE3020081 Dwg WW mod 11913299-000-2

The DS1 LRU inserts timing on DS1 signals that are typically connected to both sides of a DSX-1 panel in a Central Office. Side 1 of the DS1 re-timer provides “3R” (Re-shape, Re-amplify, and Re-time) for the DS1 signal to a client Network Element. When the LRU receives a DS1 data stream, it re-times the data with the transmit clock signal. The clock signal is inserted into the DS1 line route between two DS1 path-terminating elements. Side one is the direction in which timing is applied. Side 1 contains the DS1 line performance reporting and AIS generator. AIS is not generated when the port is set to Unused/Off. Side 2 provides “2R”, which Re-shapes and Re-amplifies (regenerates) the DS1 signal from the client Network Element. Side 2 does not provide performance monitoring or AIS generation.



Note: Side 1 is the “3R” port, and is sometimes known as East. Side 2 is the “2R” port, and is sometimes known as West.

The LRM is installed into an SSU-2000 plug-in module slot and is configured as an output. The CTA plugs into the LRM’s corresponding rear panel connector and provides a path for the DS1 signal if the unit loses power, or if the main re-timing module is removed. [Figure 8-21](#) illustrates Symmetricom’s recommended installation configuration.

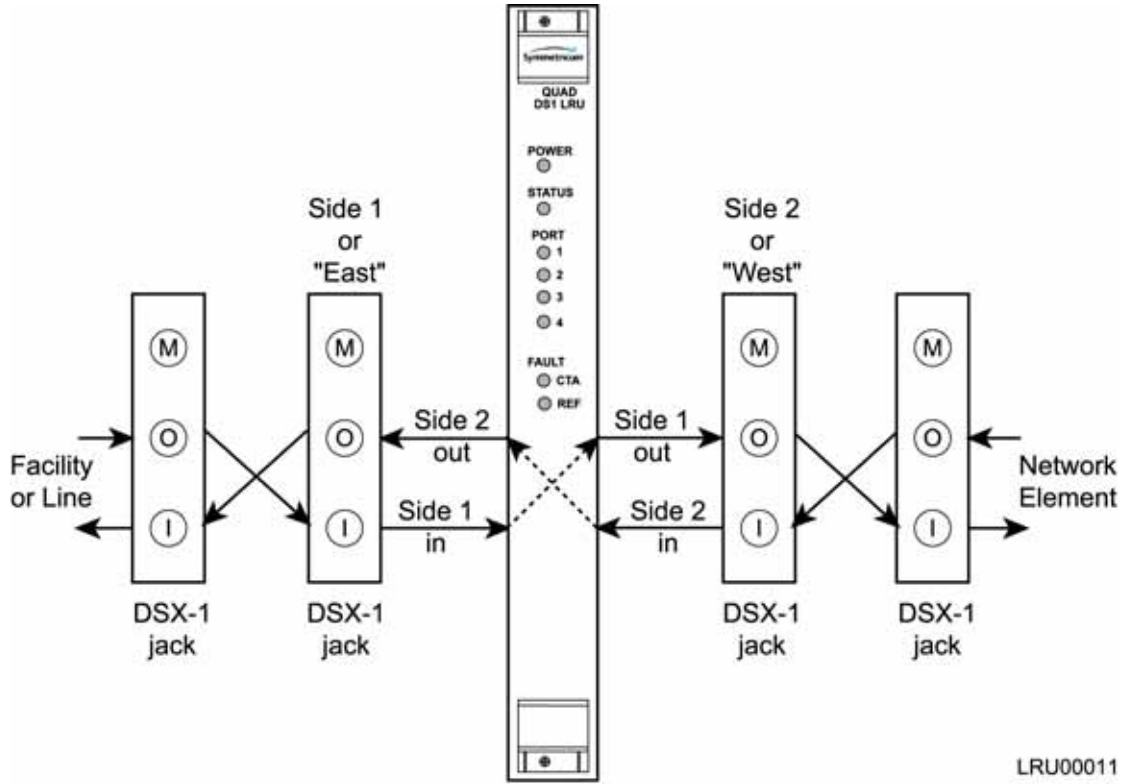

Figure 8-21. Recommended Installation Schematic for the DS1 LRU

Functional Overview

The Line Re-timing Module (LRM) consists of the following functional blocks:

- Microcontroller unit
- Memory (FLASH and RAM)
- LED indicators (module and port status)

Figure 8-22 is a block diagram of the DS1 LRU module.

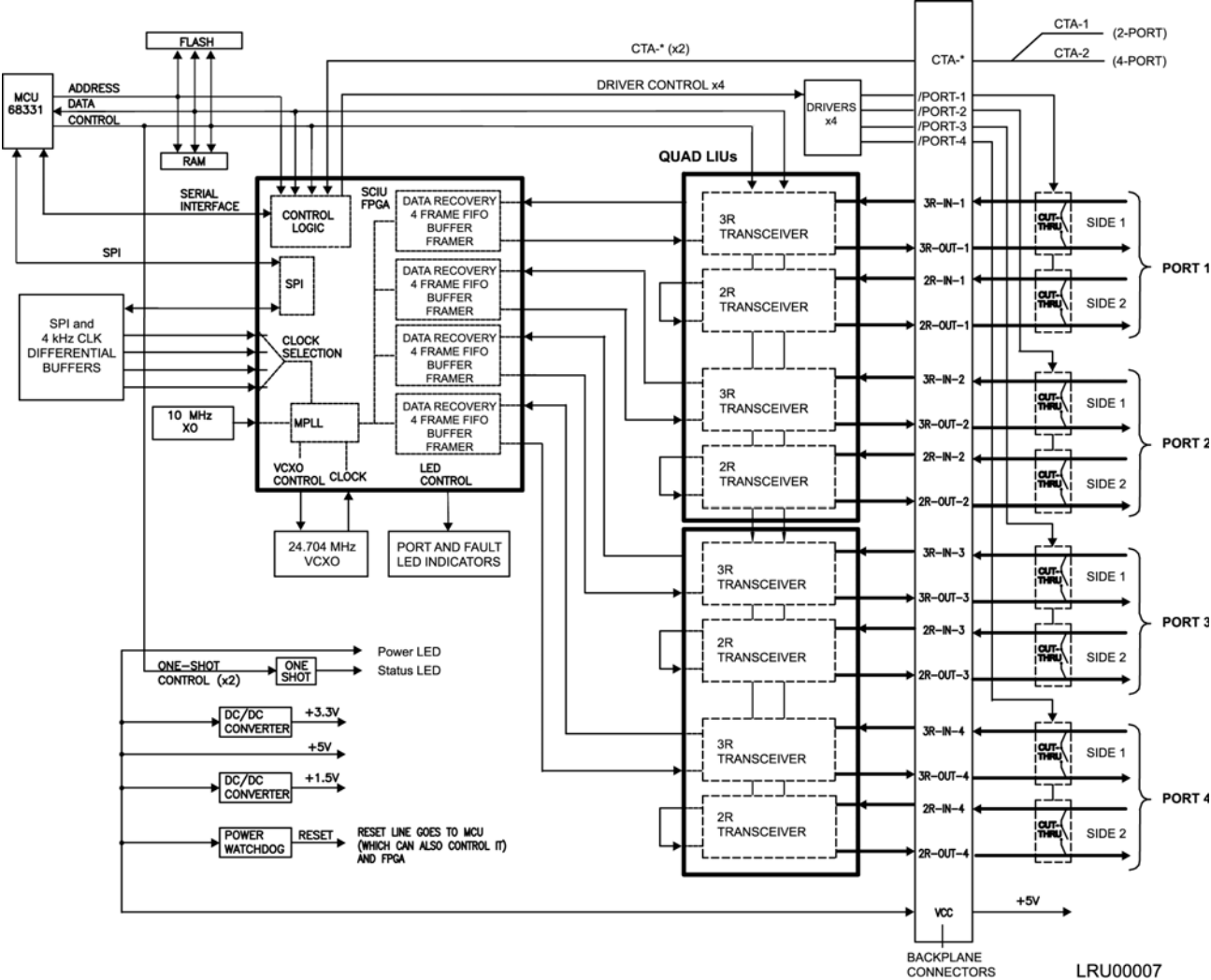

Figure 8-22. Block Diagram of the DS1 LRU Module

Microcontroller Unit (MCU)

The microcontroller unit (MCU) supports the Motorola Serial Peripheral Interface (SPI) protocol and performs interface functions with the other boards in the shelf (via the SPI bus), configuration of the LRM, and monitoring. The SPI allows module provisioning and generates events based on module status, clock reference status, and port status.

An internal MCU one-shot watchdog timer monitors the MCU for activity and controls the STATUS LED. It is responsible for placing the CTA into bypass, re-starting the MCU, and re-initializing the module when the module malfunctions.

Memory

The module’s on-board memory stores the executable image, the FPGA image, and any persistent or non-persistent information that the processor may need. The module has 512 Kilobytes of RAM for dynamic memory storage with 256 Kilobytes of FLASH memory used to store the program code and configuration information for the FPGA.

Status LED Indicators

Eight LEDs on the front panel of the module show the current status of the module. The front panel LEDs are shown in [Figure 8-23](#) and are described in [Table 8-22](#).

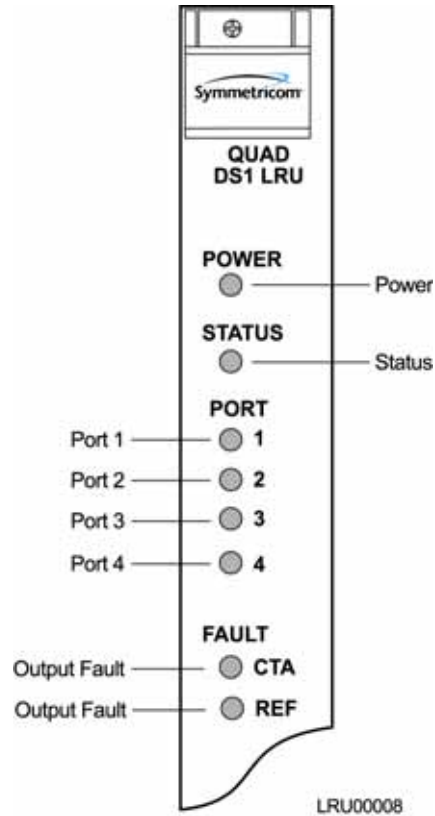

Figure 8-23. Front Panel of the DS1 LRU Four-Port Module

Table 8-22. DS1 LRU Module Status LED Indicators

Indicator	Color	Description
POWER	Green	On = +5 V DC power available on the module
STATUS	Green/Amber	On (Green) = Module functioning correctly Blinking = Module is disabled or downloading firmware On (Amber) = Module failure
PORT 1, 2, 3, and 4	Green/Amber	On (Green) = Selected On (Amber) = Not good and ignored Off = Disabled, alarms ignored, or good and not selected
FAULT CTA	Green/Amber	On (Green) = CTA connected On (Amber) = CTA not connected or CTA mismatch Off = CTA not connected and alarm set to ignore
FAULT REF	Green/Amber	On (Green) = Clock reference selected On (Amber) = Clock reference not selected

Installing the Line Re-timing Unit

This section contains procedures for installing the Line Re-timing Module (LRM) and the Cut-Through Assembly (CTA) in an SSU-2000 and in an SDU-2000.

Installing the Line Re-Timing Module in the SSU-2000

The SSU-2000 shelf has twelve plug-in module slots. The slots are numbered A1 through A12, from left to right looking at the front of the shelf. When you install a Line Re-timing Module into an SSU-2000, Symmetricom recommends that you use only slots A6, A7, A8, or A9 as shown in [Figure 8-24](#). Using only the specified slots allows you to maintain redundant configuration options on other modules.



Note: You can install and remove modules while system power is supplied without damaging modules or affecting system operation.



Caution: For continued EMC compliance, replace all deformed module gaskets with the same type. Clean gaskets and mating surfaces. Secure all modules with captive screws.

Use the following steps to install a Line Re-timing module in an SSU-2000.

1. Align the module card edges with the plastic card guides of the selected slot.
2. Slide the module into the chassis until it seats fully into its rear panel edge connector.
3. Tighten the captive screws located at the top and bottom of the module front panel.



Caution: To avoid possible damage or intermittent failure, ensure that you have completely inserted the module into the shelf and that you have securely tightened the captive screws. A partially inserted module can easily become damaged and cause intermittent failures.

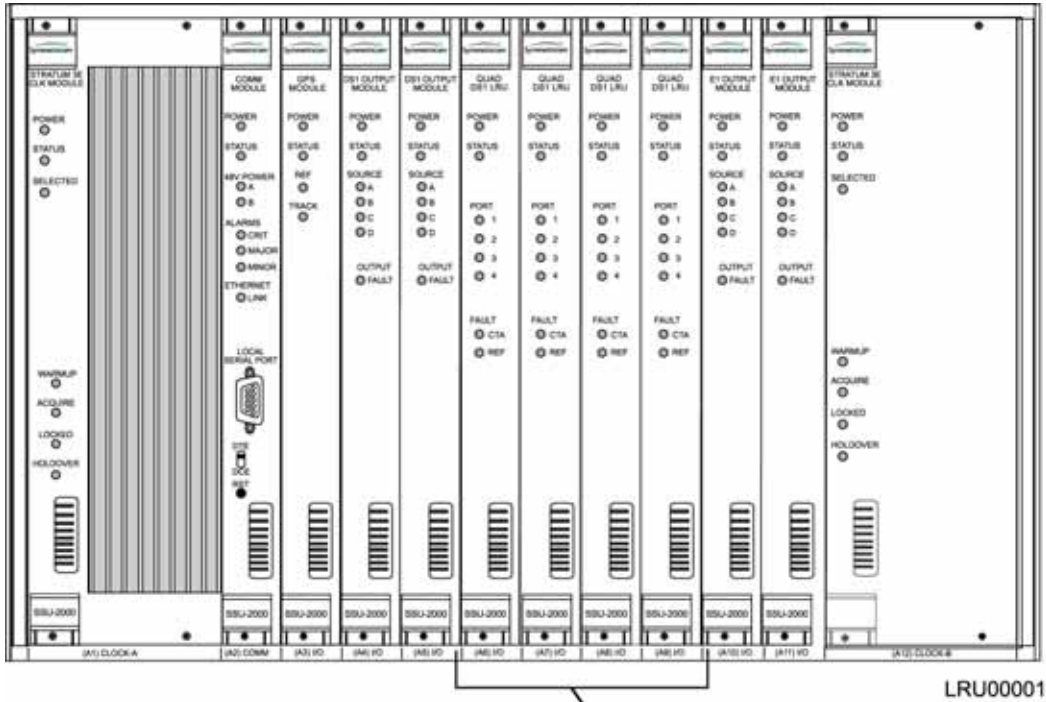

Figure 8-24. Recommended SSU-2000 Slots for Installing the DS1 LRM

Installing the LRM in the SDU-2000

The SDU-2000 shelf has sixteen plug-in module slots. The slots are numbered A1 through A16, from left to right looking at the front of the shelf. When you install a Line Re-timing Module into an SDU-2000, Symmetricom recommends that you use only slots A5 through A12 as shown in Figure 8-25. Using only the specified slots allows you to maintain redundant configuration options on other modules.



Note: Modules can be removed and inserted while system power is supplied without damaging modules or affecting system operation.



Caution: For continued EMC compliance, replace all deformed module gaskets with the same type. Clean gaskets and mating surfaces. Secure all modules with captive screws.

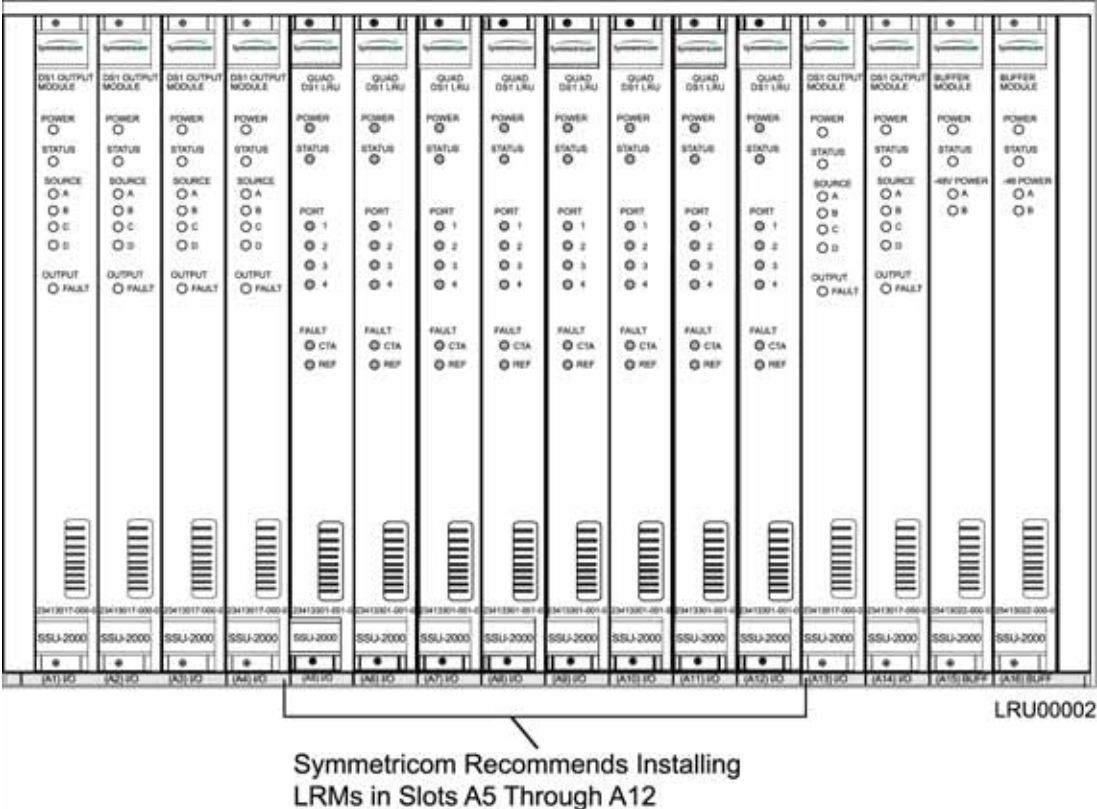

Figure 8-25. SDU-2000 Recommended Slots for DS1 LRM Installation

Use the following steps to install a DS1 Line Re-timing Module in an SDU-2000.

1. Align the module card edges with the plastic card guides of the selected slot.
2. Slide the module into the chassis until it seats fully into the edge connector.
3. Tighten the captive screws located at the top and bottom of the front panel.



Caution: To avoid possible damage or intermittent failure, ensure that you have completely inserted the module into the shelf and that you have securely tightened the captive screws. A partially inserted module can easily become damaged and cause intermittent failures.

Installing a Cut-Through Assembly in the SSU-2000

The SSU-2000 shelf has I/O interface connections on the rear panel for connecting the SSU-2000 to the corresponding I/O adapter panels. The LRM I/O connections are made from the 50-pin Micro-D female connectors on the SSU-2000 rear panel, through the CTA, and to the adapter panel using the appropriate cable. Connectors J10 through J18 on the rear panel are labeled I/O-1 through I/O-9; each connector is associated with a specific I/O plug-in module slot. Symmetricom recommends using connectors J13 through J16, which correspond to module slots A6 through A9 respectively (see [Figure 8-26](#)).



Caution: To avoid signal faults, do not install a Cut-Through Assembly on top of a Summer Adapter.

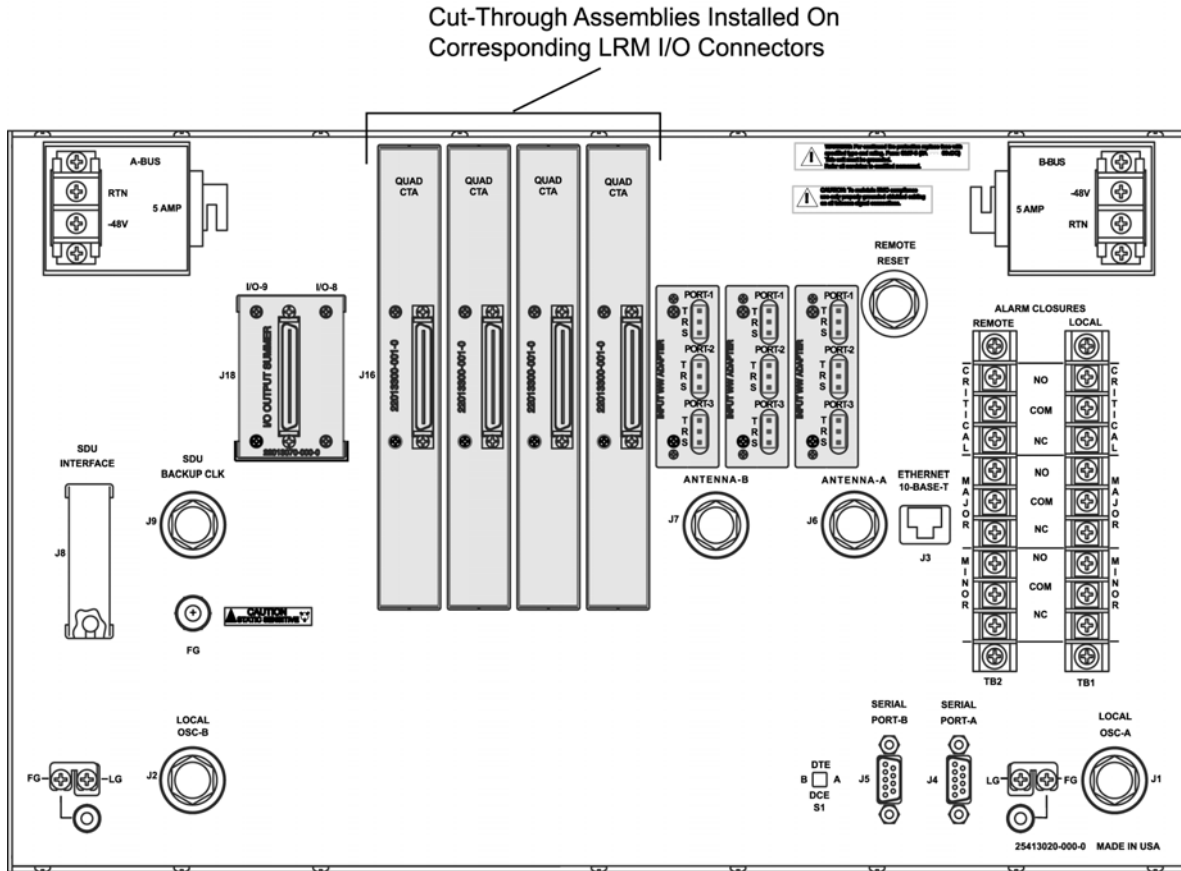

LRU00003

Figure 8-26. Installing the Cut-Through Assembly in the SSU-2000

Use the following steps to install the Cut-Through Assembly on an SSU-2000. Refer to [Table 8-23](#) for a description of the SSU-2000 and CTA I/O connector pin functions and to [Figure 8-28](#) for pin orientation.

1. Remove the two screws on each I/O connector that a CTA is to be installed on.



Caution: To avoid possible electrostatic discharge problems after removing a CTA connector, you must replace the screws securing the I/O connectors on the rear panel of the SSU-2000.

2. Install CTA connectors on all outputs corresponding to installed LRMs.
3. Tighten all CTA connector screws securely.
4. Connect 50-pin Micro-D output cables as required for your application.

Installing a CTA in the SDU-2000

The SDU-2000 shelf has I/O interface connections on the rear panel for connecting the SDU-2000 to the corresponding I/O adapter panels. The LRM I/O connections are made from the 50-pin Micro-D female connectors on the rear panel of the SDU-2000, through the CTA, and to the adapter panel using the appropriate cable. Connectors J1 through J14 are labeled OUT-1 through OUT-14 and each connector is associated with a specific I/O plug-in module slot. Symmetricom recommends using connectors J5 through J12, which correspond to module slots A5 through A12 respectively (see [Figure 8-27](#)).

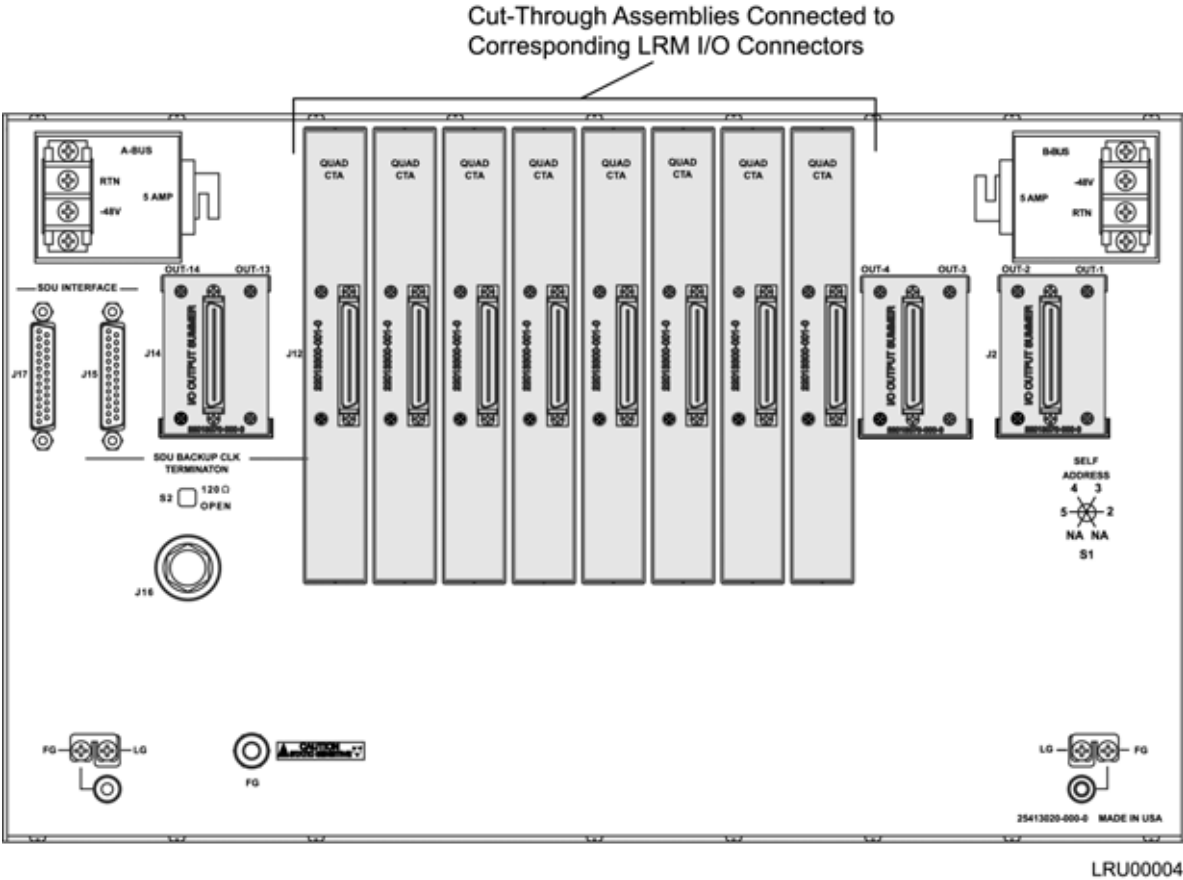

Figure 8-27. Installing the Cut-Through Assembly in the SDU-2000

Use the following steps to install the Cut-Through Assembly on an SDU-2000. Refer to [Table 8-23](#) for a description of the SSU-2000 and CTA I/O connector pin functions and to [Figure 8-28](#) for pin orientation.



Caution: To avoid possible electrostatic discharge problems after removing a CTA connector, you must replace the screws securing the I/O connectors on the rear panel of the SDU-2000.

1. Remove the two screws on each I/O connector that a CTA is to be installed on.
2. Install CTA connectors on all outputs corresponding to installed LRMs.

3. Tighten all CTA connector screws securely.
4. Connect the 50-pin Micro-D output cables as required for your application.

Table 8-23. SSU-2000 and CTA I/O Pin Description

Pin Number	Function (LRU Applications Only)	CTA Pin Function	Pin Number	Function (LRU Applications Only)	CTA Pin Function
1	Not Connected	Not Connected	26	Not Connected	Not Connected
2	3R-ITIP-1	3R-ITIP-1	27	3R-IRING-1	3R-IRING-1
3	Not Connected	Not Connected	28	Not Connected	Not Connected
4	3R-OTIP-1	3R-OTIP-1	29	3R-ORING-1	3R-ORING-1
5	2R-ITIP-1	2R-ITIP-1	30	2R-IRING-1	2R-IRING-1
6	2R-OTIP-1	2R-OTIP-1	31	2R-ORING-1	2R-ORING-1
7	RELAY SINK PORT-1	Not Connected	32	RELAY SINK PORT-2	Not Connected
8	3R-ITIP-2	3R-ITIP-2	33	3R-IRING-2	3R-IRING-2
9	3R-OTIP-2	3R-OTIP-2	34	3R-ORING-2	3R-ORING-2
10	2R-ITIP-2	2R-ITIP-2	35	2R-IRING-2	2R-IRING-2
11	2R-OTIP-2	2R-OTIP-2	36	2R-ORING-2	2R-ORING-2
12	CTA-1 (2-PORT)	Not Connected	37	5vDC	Not Connected
13	Not Connected	Not Connected	38	Not Connected	Not Connected
14	3R-ITIP-3	3R-ITIP-3	39	3R-IRING-3	3R-IRING-3
15	3R-OTIP-3	3R-OTIP-3	40	3R-ORING-3	3R-ORING-3
16	2R-ITIP-3	2R-ITIP-3	41	2R-IRING-3	2R-IRING-3
17	2R-OTIP-3	2R-OTIP-3	42	2R-ORING-3	2R-ORING-3
18	RELAY SINK PORT-3	Not Connected	43	RELAY SINK PORT-4	Not Connected
19	3R-ITIP-4	3R-ITIP-4	44	3R-IRING-4	3R-IRING-4
20	3R-OTIP-4	3R-OTIP-4	45	3R-ORING-4	3R-ORING-4
21	2R-ITIP-4	2R-ITIP-4	46	2R-IRING-4	2R-IRING-4
22	2R-OTIP-4	2R-OTIP-4	47	2R-ORING-4	2R-ORING-4
23	Not Connected	Not Connected	48	DO NOT CONNECT	Not Connected
24	CTA-2 (4-PORT)	Not Connected	49	5vDC	Not Connected
25	FRAME GROUND	Not Connected	50	FRAME GROUND	Not Connected

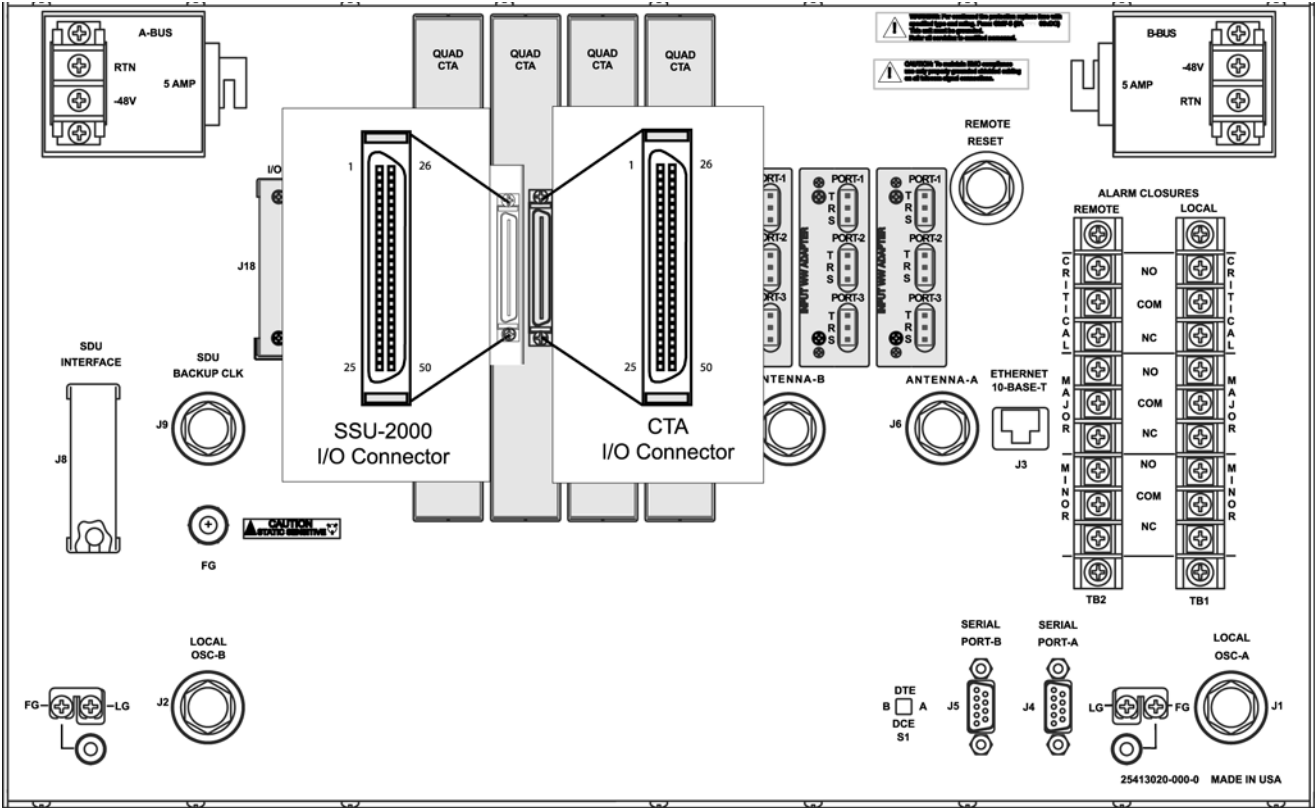

LRU00009

Figure 8-28. Orientation of the SSU-2000 I/O and CTA I/O Connector Pins

Installing the Optional Wire-Wrap Panel Overlay

The adapter panel identification overlay is a user-installed label that identifies each port's side 1 and side 2 wire-wrap pins (see [Figure 8-29](#)).



Note: The label must be installed before you make the wire-wrap connections.

Use the following steps to install the wire-wrap identification overlay on the Puleo adapter panel.

1. Identify the appropriate twenty-pin groups for your application.
2. Align the label's holes with the panel's selected twenty-pin groups.
3. Carefully push the label over the pins until it is flush with the panel. The label is secured in place by the physical wire-wrap connections and is not glued to the panel.

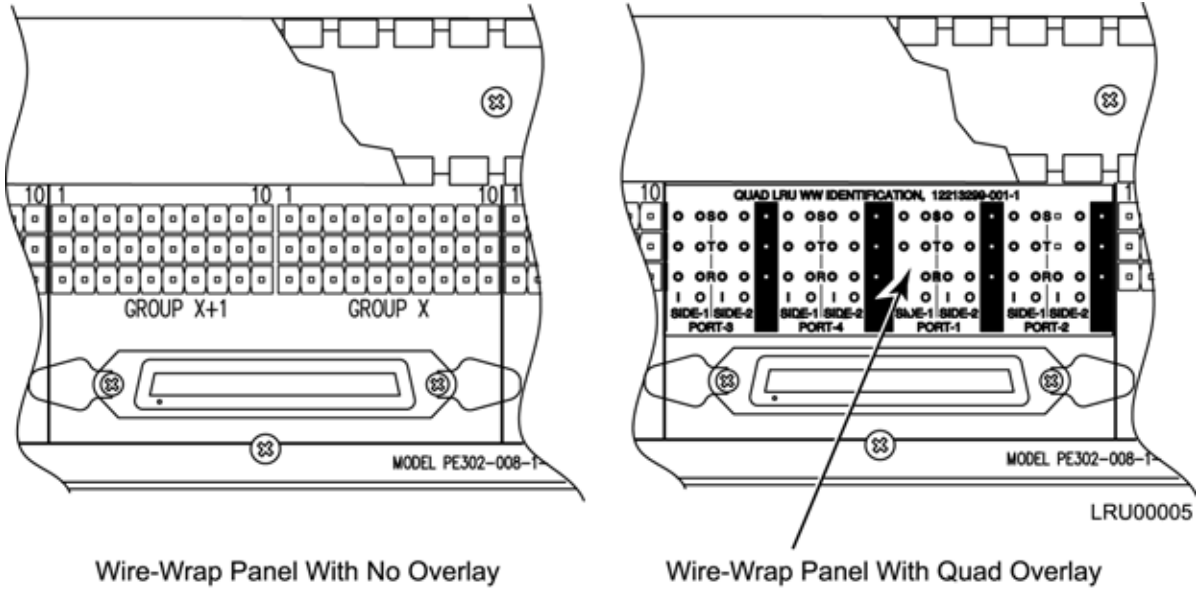

Figure 8-29. Wire-wrap Identification Overlay

Specifications

Table 8-14 lists specifications for the Line DS1 Re-timing module.

Table 8-24. Line Re-timing Module Specifications

Performance Characteristic	Specification
Termination	100Ω
Waveshape	Per ANSI T1.102 and ITU-T G.703, October 1998
Signal	DS1
Number of Ports	2 or 4

Provisioning the DS1 Line Re-timing Module

The following information provides examples of how to use ICS and TL1 commands to provision a DS1 Line Re-timing module in an SSU-2000. Refer to the *SSU-2000 Technical Reference* for details on ICS and TL1 commands.

Examples

The following ICS commands enable port 2 on an LRM in slot 8 of shelf 3, set the line build-out to 399 feet, and set the slip error threshold to 6:

```
LRM 3A8-2 ENABLE then press Enter
```

```
LRM 3A8-2 LBO 399 then press Enter
```

LRM 3A8-2 SLIP 6 then press **Enter**

```
SET-PRMTR-LRM::S3A8-2:::ON,399,6,,;
```

The following ICS commands enable port 3 of an LRM in slot 11 of shelf 2 and enables a FAULT strategy,:

LRM 2A11-3 FLT AIS then press **Enter**

```
SET-PRMTR-LRM::S2A11-3:::ON,,,,,AIS;
```

The following ICS and TL1 commands set the circuit ID of port 4 on an LRM in slot 7 of shelf 1 to 1A7-4:

LRM 1A7-4 CID 1A7-4 then press **Enter**

```
SET-PRMTR-LRMCID::S1A7-4:::1A7-4;
```

Alarms and Events

The *SSU-2000 Technical Reference* contains a list of the DS1 LRM alarms and events.

E1 Line Re-timing Unit

This section provides information on the installation and operation of the Symmetricom E1 Line Re-timing Module (LRM) designed for operation in SSU-2000 Synchronization Supply Unit and the SDU-2000 Expansion Unit. This section lists the TL1 and ICS commands for the E1 LRM along with some examples of how to use the commands.

The LRM is available in a four-port (Quad) version, and is used in conjunction with cut-through assembly output panels designed specifically for use with the E1 LRM. Part numbers are as follows:

- Quad E1 LRM – 23413309-001-0
- Adapter Assembly Output Panel – DE 9 22013298-001-0
- Adapter Assembly Output Panel – 75 Ω BNC 22013310-001-0
- Adapter Assembly Output Panel – 75 Ω Siemens 1.6/5.6 mm 22013310-002-0
- Adapter Assembly Output Panel – 75 Ω Siemens 1.0/2.3 mm 22013310-003-0

Functional Overview

The E1 Line Re-timing Module (LRM) consists of the following functional blocks:

- Power input regulation
- Microcontroller unit
- Memory (FLASH and RAM)
- LED indicators (module and port status)

Figure 8-30 is a block diagram of the E1 LRM module.

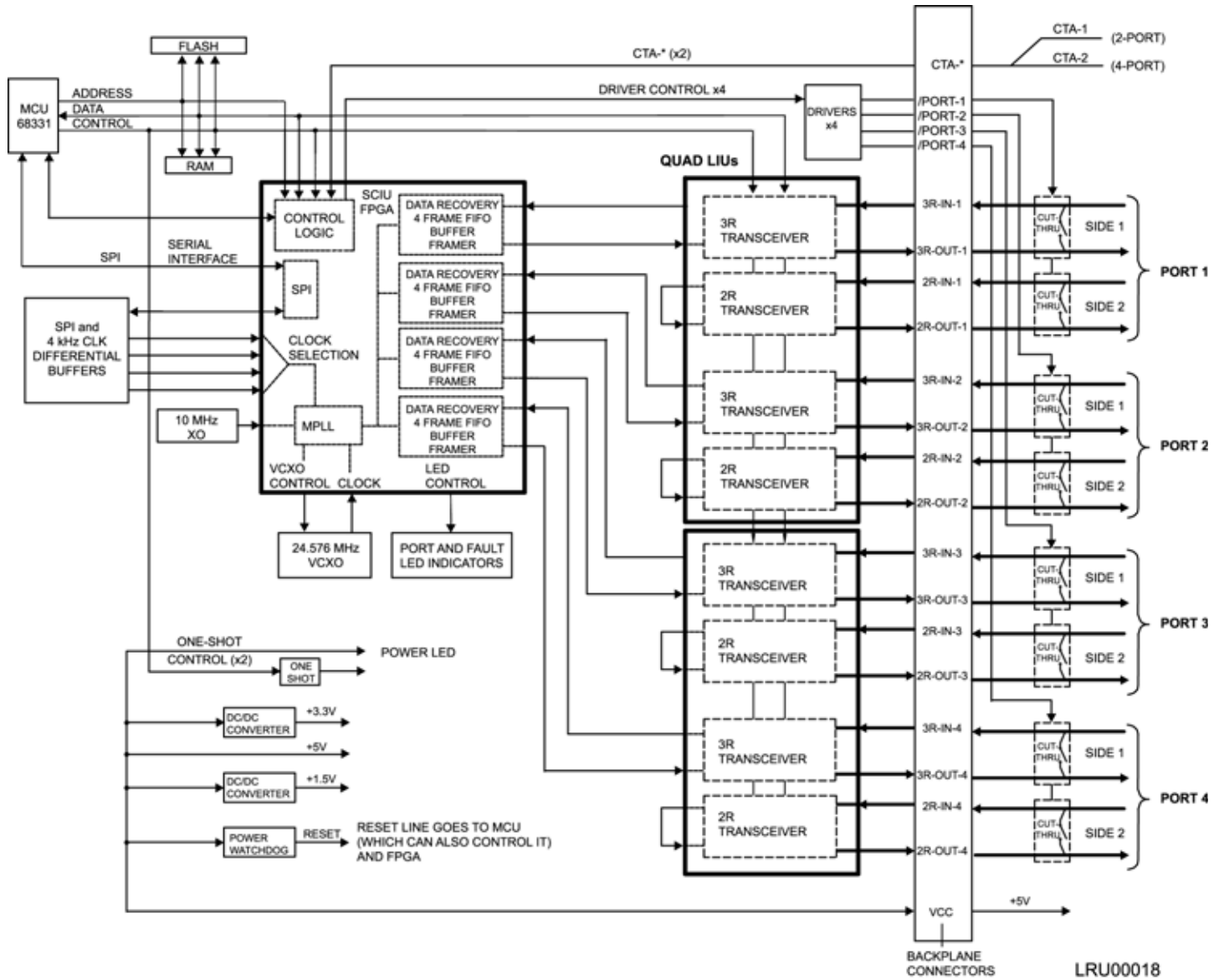

Figure 8-30. E1 LRM Block Diagram

Micro-Controller Unit (MCU)

The microcontroller unit (MCU) supports the Motorola Serial Peripheral Interface (SPI) protocol and performs interface functions with the other boards in the shelf (via the SPI bus), configuration of the LRM, and monitoring. The SPI allows module provisioning and generates events based on module status, clock reference status, and port status.

An internal MCU one-shot watchdog timer monitors the MCU for activity and controls the STATUS LED. It is responsible for placing the CTA into bypass, re-starting the MCU, and re-initializing the module when the module malfunctions.

Memory

The module’s on-board memory stores the executable image, the FPGA image, and any persistent or non-persistent information that the processor may need. The module has 512 Kilobytes of RAM for dynamic memory storage with 256 Kilobytes of FLASH memory used to store the program code and configuration information for the FPGA.

Status LED Indicators

Eight LEDs on the front panel show the current operating status of the module. The LEDs are shown in [Figure 8-30](#) and are described in [Table 8-25](#).

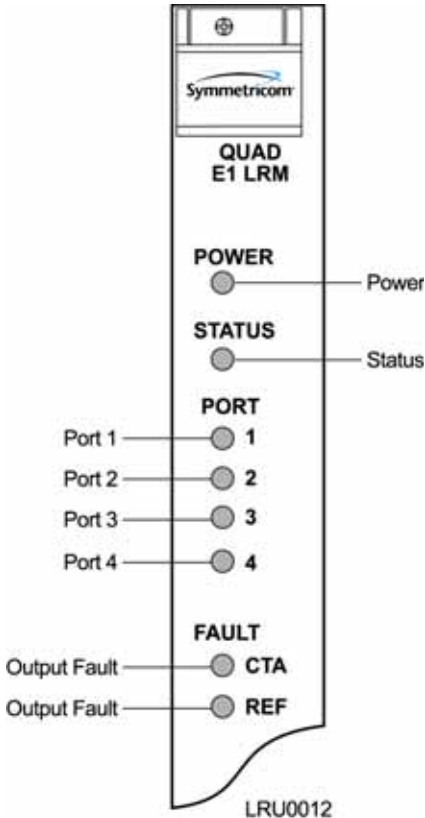

Figure 8-31. Front Panel of the E1 LRM

Table 8-25. Status LED Indicators on the E1 LRU

Indicator	Color	Description
POWER	Green	On = +5 V DC power available on the module
STATUS	Green/Amber	On (Green) = Module functioning correctly Blinking = Module disabled or downloading firmware On (Amber) = Module failure
PORT 1, 2, 3, and 4	Green/Amber	On (Green) = Enabled, functioning correctly On (Amber) = Enabled, problem detected Off = Disabled
FAULT CTA	Green/Amber	On (Green) = CTA connected On (Amber) = CTA not connected or CTA mismatch Off = CTA not connected and alarm set to ignore
FAULT REF	Green/Amber	On (Green) = Clock reference selected On (Amber) = Clock reference not selected

Installing the E1 Line Re-timing Module

You can install the E1 LRM in any available I/O slot on both the SSU-2000 shelf and the SDU-2000 Expansion Shelf. The I/O slots on the SSU-2000 are labeled A3 through A11. The Output slots on the SDU-2000 are labeled A1 through A14.



Note: Modules can be removed and inserted while system power is supplied without damaging modules.



Caution: For continued EMC compliance, replace all deformed module gaskets with the same type. Clean gaskets and mating surfaces. Secure all modules with captive screws.

Use the following steps to install an E1 Line Re-timing module either in an SSU-2000 or SDU-2000.

1. Align the module card edges with the plastic card guides of the selected slot.
2. Slide the module into the chassis until it seats fully into its rear panel edge connector.

3. Tighten the captive screws located at the top and bottom of the module front panel.



Caution: To avoid possible damage or intermittent failure, ensure that you have completely inserted the module into the system and that you have securely tightened the captive screws. A partially inserted module can easily become damaged and cause intermittent failures.

Installing the Output Panels

The location of the output panels is limited only by the length of the interconnecting cable. Output adapter cables are available in lengths from one to two meters in increments of 0.1 meter; see the User Guide for part numbers. Use the following steps to install the output panels.

1. The I/O adapter panels may be mounted flush to the top or bottom of the SSU-2000 shelf, as shown in [Figure 8-32](#). Use suitable screws for attaching the Output Adapter panel to the rack.
2. Mount the panels to the front of the rack rails with four screws and washers.
2. Mount the panels to the front of the rack rails with four screws and washers.

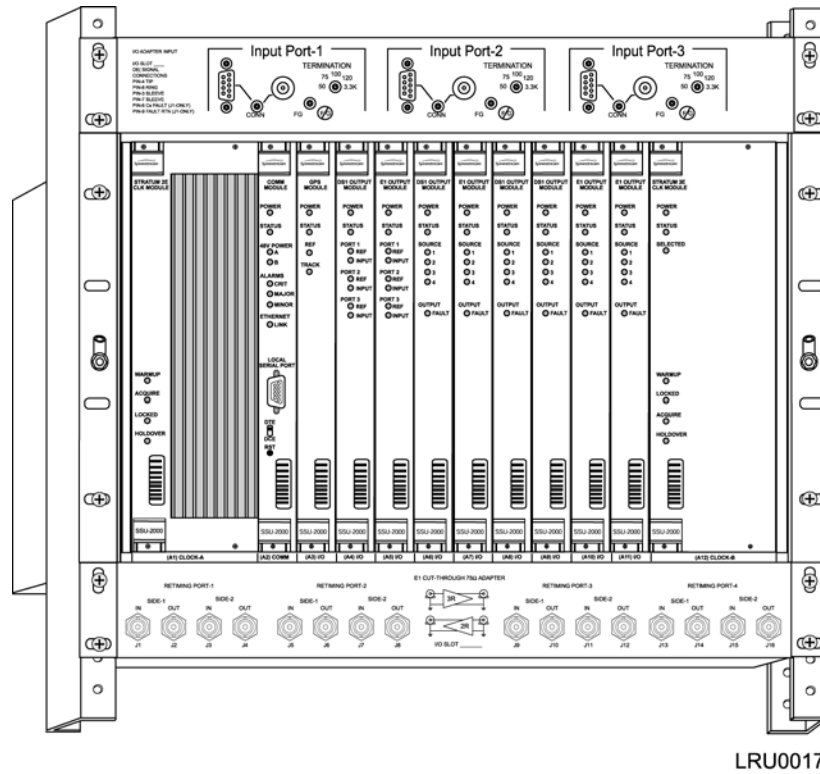

Figure 8-32. Sample Rack Mounting with Input Module, SSU-2000, and Output Panel

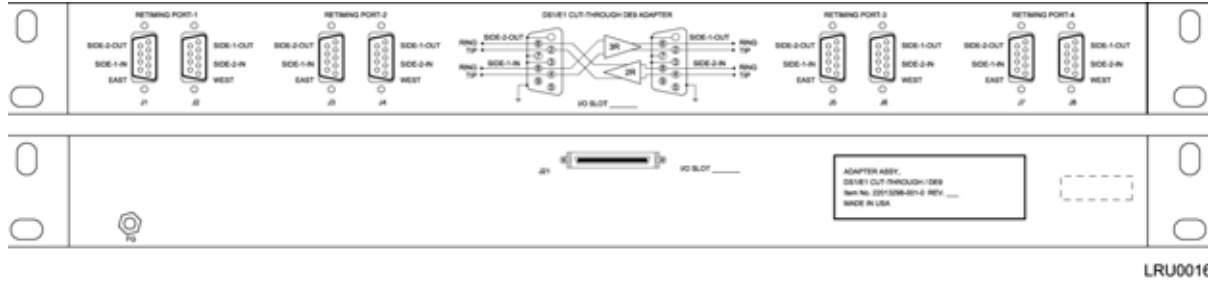

Figure 8-33. DE9 Output Panel for the E1 LRU

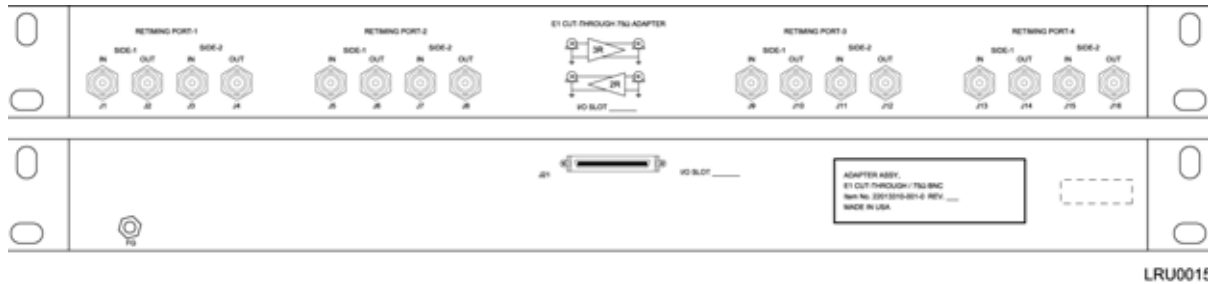

Figure 8-34. BNC Output Panel for the E1 LRU

Specifications

Table 8-26 lists the specifications for the E1 Line Re-timing Module.

Table 8-26. E1 Line Re-timing Module Specifications

Performance Characteristic	Specification
Termination	120Ω – DE9 75Ω – BNC/Siemens
Waveshape	Per ITU-T G.703, October 1998
Signal	E1
Number of Ports	4

Provisioning the E1 Line Re-timing Module

The following information provides examples of how to use ICS and TL1 commands to provision an E1 Line Re-timing module in an SSU-2000. Refer to the *SSU-2000 Technical Reference* for details on TL1 and ICS commands.

Examples

To use ICS commands to enable port 2 on an E1 LRM in slot 8 of shelf 3 and set the slip error threshold to 6, issue the following commands:

```
LRM 3A8-2 ENABLE then press Enter.  
LRM 3A8-2 SLIP 6 then press Enter.
```

To use TL1 commands to enable port 2 on an E1 LRM in slot 8 of shelf 3 and set the slip error threshold to 6, issue the command:

```
SET-PRMTR-LRME1::S3A8-2::ON,6;
```

To use ICS commands to enable port 3 of an E1 LRM in slot 11 of shelf 2 and to enable FAULT strategy, issue the command:

```
LRM 2A11-3 FLT AIS then press Enter.
```

To use TL1 commands to enable port 3 of an E1 LRM in slot 11 of shelf 2 and to enable FAULT strategy, issue the command:

```
SET-PRMTR-LRME1::S2A11-3::ON,,,,AIS;
```

To use ICS commands to set the circuit ID of port 4 on an E1 LRM in slot 7 of shelf 1 to 1A7-4, issue the command:

```
LRM 1A7-4 CID 1A7-4 and press Enter.
```

To use TL1 commands to set the circuit ID of port 4 on an E1 LRM in slot 7 of shelf 1 to 1A7-4, issue the command:

```
SET-PRMTR-LRMCID::S1A7-4::1A7-4;
```

Alarms and Events

The *SSU-2000 Technical Reference* contains a list of the E1 LRM alarms and events.

Buffer Module

This section describes the Buffer module (part number 23413122-000-0) used in the SDU-2000 Expansion shelf. The Buffer module buffers the backplane and clock signals sent from the main shelf; the modules are installed in slots 15 and 16 of the SDU-2000. Symmetricom recommends a minimum of one Buffer module in each expansion shelf; a second Buffer module provides redundancy.

Status Indicators

The Buffer module indicators (LEDs) are shown in [Figure 8-35](#) and described in [Table 8-27](#).

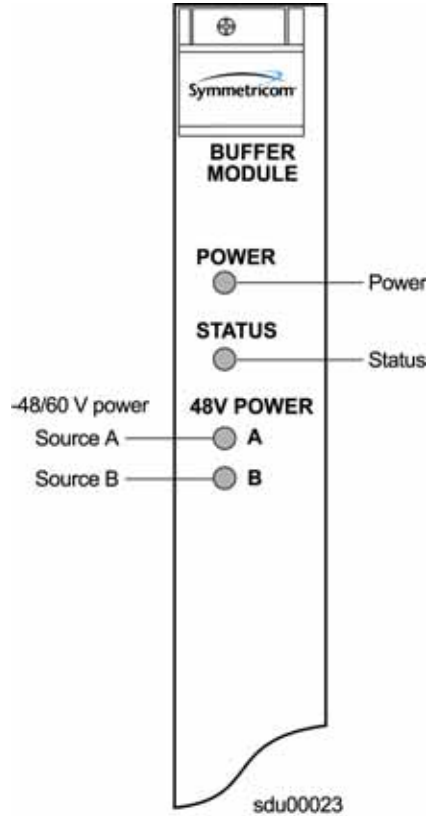

Figure 8-35. Front Panel of the Buffer Module

Table 8-27. Buffer Module LED Indicators

Indicator	Color	Description
POWER	Green	On = Receiving +5 V DC power
STATUS	Green/Amber	On (Green) = Module functioning correctly On (Amber) = Module failure
-48V Power A	Green/Amber	On (Green) = Receiving input power from Power A On (Amber) = Power connections reversed Off = Loss of input Power A
-48V Power B	Green/Amber	On (Green) = Receiving input power from Power B On (Amber) = Power connections reversed Off = Loss of input Power B

Output Adapter Panels

Balun Output Adapter Panel

Symmetricom offers four Balun Output Adapter panels for use with 2048 kHz and E1 Output modules. One adapter panel is required for each Output module in the shelf. You need one Output cable (see [Adapter Accessories](#), on page 262, for a list of available cables) to connect the Adapter panel to the shelf.

- The Balun Output Adapter panel (part number 22013068-001-0) uses BNC connectors. [Figure 8-36](#) shows an I/O Adapter with Balun outputs.
- The Balun Output I/O Adapter panel (part number 22013068-002-0) uses Siemens 1.6/5.6 mm connectors.
- The Balun Output I/O Adapter panel (part number 22013068-003-0) uses Siemens 1.0/2.3 mm connectors.
- The Balun Output I/O Adapter panel (part number 22013316-000-2) uses BT43 connectors.

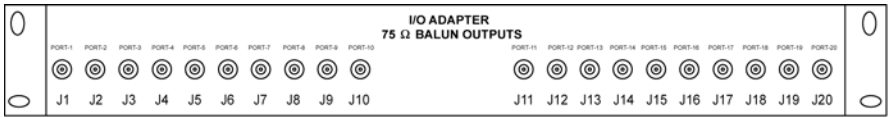

ss200020

Figure 8-36. Balun Output I/O Adapter Panel for Output Module

DE9 Output Adapter Panel

The DE9 Output Adapter panel (part number 22013067-001-0) for the DS1 and E1 Output module is shown in [Figure 8-37](#). One Adapter panel accommodates the 20 output signals generated by one Output module. You need one Output cable (see [Adapter Accessories](#), on page 262, for a list of available cables) to connect the Adapter panel to the shelf.

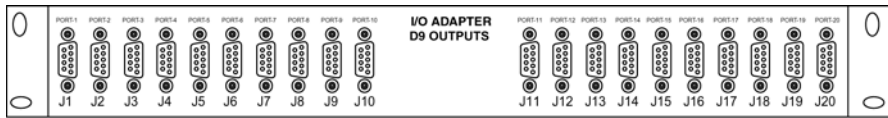

ss200021

Figure 8-37. Output I/O Adapter Panel, DE9 Outputs

High-Density Wire-Wrap Output Panels

Symmetricon offers two high-density wire-wrap panels that can be used for any of the Output modules. A 100-output panel is available for 23" racks, and an 80-output panel is available for 19" racks. You need four Output cables to connect the 80-output Adapter panel to the shelf and five Output cables to connect the 100-output Adapter panel to the shelf. All necessary cables are delivered with the panel.

Figure illustrates the two high-density wire-wrap output panels.

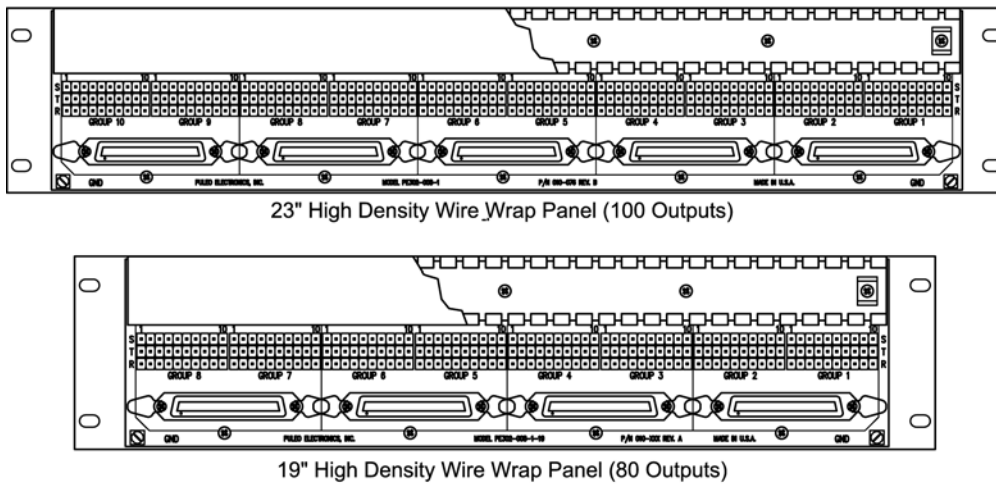

High-Density Wire-Wrap Output Panels

tsg00022

The part number for the 23-inch, 100-output wire-wrap panel is 12813171-000-0; the part number for the 19-inch, 80-output wire-wrap panel is 12813282-000-0.

Adapter Accessories

Symmetricon provides a number of accessories to ensure a complete and professional installation. Table 8-28 lists the cables available.

Table 8-28. Adapter Cables

Part Number	Description
060-10003-10-2	Cable, 50-pin SCSI, 1.0 m long
060-10003-11-2	Cable, 50-pin SCSI, 1.1 m long
060-10003-12-2	Cable, 50-pin SCSI, 1.2 m long
060-10003-13-2	Cable, 50-pin SCSI, 1.3 m long
060-10003-14-2	Cable, 50-pin SCSI, 1.4 m long
060-10003-15-2	Cable, 50-pin SCSI, 1.5 m long

Table 8-28. Adapter Cables

Part Number	Description
060-10003-16-2	Cable, 50-pin SCSI, 1.6 m long
060-10003-17-2	Cable, 50-pin SCSI, 1.7 m long
060-10003-18-2	Cable, 50-pin SCSI, 1.8 m long
060-10003-19-2	Cable, 50-pin SCSI, 1.9 m long
060-10003-19-2	Cable, 50-pin SCSI, 2.0 m long
805SCSI-TLCO	Cable, 50-pin SCSI, to 50-pin TELCO connector

Chapter 9 Hardware Configuration Guide

This chapter describes how to configure the SSU-2000 into a variety of telecommunications configurations, depending on which modules are installed.

In This Chapter

- [Configuring a Conventional SSU/TSG System](#)
- [Configuring a Primary Reference Source \(PRS\) System](#)
- [Configuring a Monitor-Only System](#)
- [Configuring a Subtending SSU](#)
- [SSU-2000 Configuration Chart](#)

Configuring a Conventional SSU/TSG System

The SSU/TSG configuration allows for input of external references to which the Clock modules are phase locked. This configuration allows for monitoring of several inputs and for synchronization of output signals. [Figure 9-1](#) shows a TSG configuration.

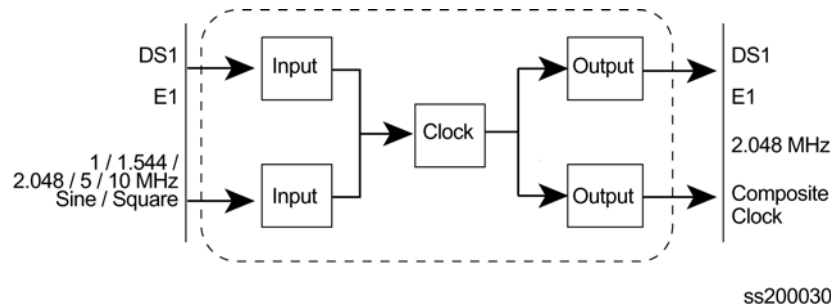

Figure 9-1. Time Sync Generator (TSG) System Configuration

The TSG configuration consists of the following:

- SSU-2000 main chassis
- Communications Module
- One or more E1/DS1 input modules
- Corresponding number of Input I/O adapter panels and input I/O cables
- One or two Clock Module(s) (2E/3E)
- One or more E1 and/or DS1 Output Module(s)
- Corresponding number of Output I/O adapter panels and SCSI output cables
- Seven 1.0-inch wide filler panels and one 3-1/2" wide filler panel

Configuring a Primary Reference Source (PRS) System

In a Primary Reference Source (PRS) configuration, the SSU-2000 meets the specifications defined in American National Standards Institute (ANSI) T1.101-1994. ANSI defines a Primary Reference Source as “equipment that provides a timing signal whose long-term accuracy is maintained at 1×10^{-11} or better, with verification to Universal Coordinated Time (UTC), and whose timing signal is used as the basis of reference for the control of other clocks within a network”. If standard Input modules are installed in the remaining input slots, this configuration also allows for monitoring of other external signals, such as DS1, E1, composite clock, and various clock frequencies. Time-of-day functionality is available via the Ethernet port employing NTP. [Figure 9-2](#) shows a PRS configuration.

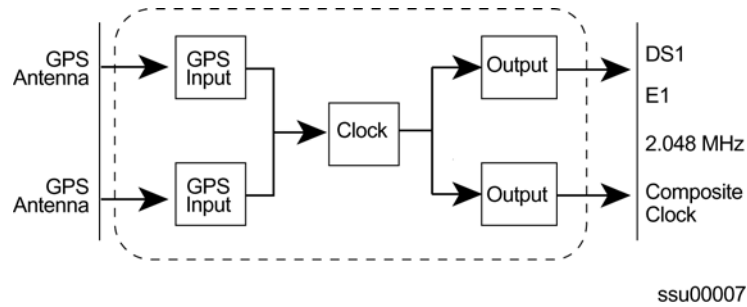

Figure 9-2. SSU-2000 Configured as PRS System

The SSU-2000 PRS configuration consists of the following:

- SSU-2000 main chassis
- Communications Module
- One or two GPS Input Modules
- One Clock Module (2E or 3E)
- One or more E1 and/or DS1 Output Modules
- One Input Adapter Panel and I/O cable
- One Output Adapter Panel and SCSI Output cable
- Seven 1.0-inch wide filler panels and one 3-1/2" wide filler panel

Configuring a Monitor-Only System

In a monitor-only configuration, no output signals are required. One of the inputs is designated as the reference, and the SSU-2000 Clock module is locked directly to this signal. All remaining input signals are then compared to the phase-locked oscillators (and indirectly to the designated input reference). The SSU-2000 can support up to 27 inputs in this type of configuration. [Figure 9-3](#) shows a monitor only configuration.

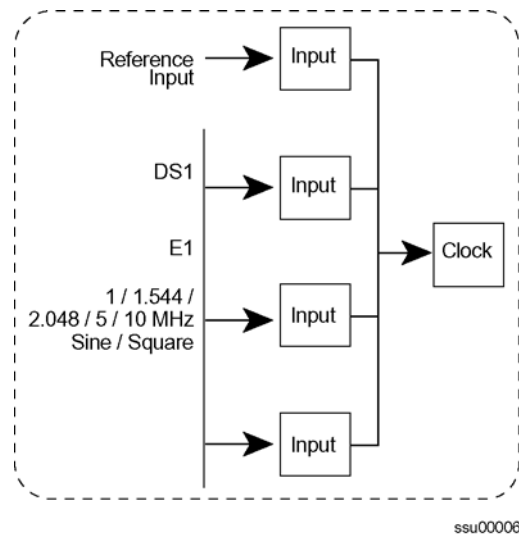

Figure 9-3. SSU-2000 Configured as Monitor-Only System

A monitor only configuration consists of the following:

- SSU-2000 main chassis with SDU Termination Plug
- Communications Module
- One or more Input Modules (one-port or three port DS1 or E1)
- Stratum 2E Clock Module
- Stratum 3E Clock Module
- One (or more) input adapter panel(s) and I/O cable; one three port input adapter required for each three-port input module in the system; one four-port input adapter required for each set of four One-Port Input Modules

Configuring a Subtending SSU

The SSU-2000 configured as a Subtending Synchronization Supply Unit (SSU) provides remote phase synchronization and holdover capabilities to telecom network elements, such as digital switches, Digital Access Crossover Systems (DACs), and channel banks for customers with very large equipment offices. For further information on Subtending SSUs, refer to Section 7 of Telcordia Specification GR-378-CORE.

The Subtending SSU configuration is designed in accordance with the Building Integrated Timing Supply (BITS) concept for intraoffice synchronization distribution. The BITS concept provides a synchronization hierarchy that is traceable back to one master clock (SSU), or redundant master clock pairs, referred to as the BITS. The BITS provides DS1 and Composite Clock (CC) timing to all synchronized clocks in the office, which provides timing inputs for all remote (subtending) SSUs.

The Subtending SSU configuration provides Composite Clock (CC) outputs that are frequency-locked and phase-aligned to the CC reference signal. If the CC input signal fails, the Clock module provides holdover.

This section contains an introduction to the hardware and software that is specific to a Subtending SSU configuration.

Functional Description

The SSU-2000 configured as a Subtending SSU broadens the Symmetricom SSU-2000 family of products by providing subtending clock functionality when referenced to a master TSG/BITS equipped with a Stratum 3E or better clock. The following combination of hardware and software configuration meets Subtending SSU criteria described in Section 7 of Telcordia Specification GR-378-CORE.

Hardware – Use the Subtending SSU when there is a need for more timing outputs or longer distribution paths than can be supplied by a single TSG. The Subtending SSU receives redundant Composite Clock (CC) or Japan Composite Clock (JCC) reference signals directly from the Master BITS Clock. The CC/JCC signals are used for primary and secondary inputs and the SSU phase-locks to the selected reference to ensure proper DS0 phase alignment throughout the office. If both CC/JCC reference inputs fail, the shelf provides Stratum 3E holdover stability. If both 3E Clock modules fail, the Subtending SSU uses the CC/JCC reference input for clock bypass operation.

Input Reference Signals – The Subtending SSU configuration requires at least one CC or JCC input signal for phase alignment of the CC/JCC output signals. The selected CC/JCC input provides measured phase information to each Clock module, where it is used to control the clock's frequency and establish the holdover value for the Clock modules. The operator can manually or automatically select the reference. Switching references can occur repeatedly without accumulating phase or frequency error. Restoring the primary reference source can return the unit to tracking the primary signal.

Software – The Subtending SSU software contains a command that allows the user to select between the normal SSU mode, the subtending mode of operation, and the JCC subtending mode.

A Communications module with Subtending SSU software installed identifies the Input, Output, and Clock modules that are provisioned in the system.

Input Section

The Input section consists of one or more CC Input modules or JCC Input modules connected to CC signals from a Master BITS shelf. Other input modules (DS1, etc.) may be installed, but in the Subtending mode these inputs are used for monitoring only, and are never selected as reference inputs for phase and frequency control of the outputs.

The CC Input modules make phase measurements between the input signal and the clock oscillator(s). From these phase measurements on the selected input, the Clock modules compute frequency offset correction and holdover value. The selected Input module also generates a 4 kHz “C” clock that is used to align the phase of the CC output signals.

Operating Mode

The operating mode of the SSU is set with the ICS command OPERMODE [NORMAL | JAPAN | SUB]. In Normal mode, the unit operates as specified in [Chapter 1, Product Overview](#). In the Subtending mode, the unit uses only the CC inputs as reference sources. The Japan mode uses only JCC inputs as reference sources; the JCC Output module’s signals are byte and polarity phase aligned with the 4 kHz clock signal from the JCC Input module. The bipolar violation (BPV) occurrences in the selected input are used to generate a signal output for phase alignment of the CC/JCC output signals. In addition, phase measurements on the selected input are used to control the average frequency of the outputs. If there is a significant difference in the BPV alignment between the selected CC/JCC input and any secondary CC/JCC inputs, the unit issues a warning that the reference signals are not phase aligned. It is the operator’s (or installer’s) responsibility to ensure that the CC/JCC inputs are from the same (master) BITS and that they are wired correctly to maintain the same polarity. A valid CC/JCC input is required when starting the Subtending mode in order to align the phase of the CC/JCC outputs.

Selecting Input References and Switching References

In the Subtending and Japan modes, the unit selects the highest priority valid CC/JCC input available. If the selected input is lost, the unit switches to any alternate CC/JCC input as specified by priority assignments; the phase and frequency of the CC outputs follow the new reference signal. If all CC/JCC inputs are invalid, the output phase continues at the last valid alignment before the input was lost; the frequency is established by the learned holdover values in the Clock modules. When a valid CC/JCC input is re-established, the CC/JCC output is immediately aligned to the selected input signal. A CC/JCC input is invalid when it is in LOS or it has invalid BPV occurrences. LOS is declared when the Input module is unable to track the expected 64 kHz input; an invalid BPV event occurs when the expected 8000 BPVs per second varies by more than $\pm 10\%$.

Output Section

The output section operates exactly the same in Subtending mode as in Normal mode, except for the CC/JCC Output modules. In the Subtending mode, the CC/JCC outputs are phase aligned with the selected CC/JCC input reference signal. The output section consists of up to 120 channels from six Output modules (60 channels from 3 redundant pairs) that reside in the main shelf and up to 1120 channels from 56 modules (560 channels from 28 redundant pairs) in a fully expanded system with four SDU-2000 expansion shelves. Each Output module type provides 20 independent output synchronization signals.

Output modules are available to support the following formats:

- DS1, SF (D4) and ESF
- E1, CAS, and CCS
- 2048 kHz
- Composite Clock (CC) (64/8 kHz)
- Japanese Composite Clock (JCC)
- Other typical clock frequencies

Setting Subtending Parameters

The SSU-2000 software includes the following new command that allows you to enable and disable the Subtending mode. For additional information on general syntax and usage, refer to the *SSU-2000 Technical Reference*.

OPERMODE

This command allows you to view and change the operating mode of the SSU-2000.

Level 0	Not applicable
Level 1	Not applicable
Level 2	Not applicable
Level 3	OPERMODE [SUB NORMAL JAPANESE] OPERMODE SYNC [1 - 10]

If you do not specify a parameter, the system displays the current mode.

SUBTENDING	Sets the SSU to Subtending mode.
NORMAL	Sets the SSU to normal TSG operation.
JAPANESE	Sets the SSU to Japanese Subtending mode.
SYNC	Perform a special operation to sync a reference clock to Clock C.
1-10	Number of steps in NCO offset, each step is 100 ns. The default value is 1 (i.e. 100 ns)

The unit must be in the subtending mode (either ANSI or Japanese) when you enter this command.

Once this command takes effect, the unit enters the SYNC process. During process, don't change selected clock and selected input reference. Typing ^C will interrupt the SYNC process. You will have a choice to stay or leave the SYNC process.

Level 4 Same as Level 3 operation.

Restrictions See [Changing to Subtending SSU Mode](#), on page 272, for hardware and software requirements.

Changing to Subtending SSU Mode

To change an SSU-2000 to a Subtending SSU, you must verify that the proper hardware is present, and you must install the appropriate software. The minimum software versions for the modules is listed in [Table 9-1](#).

Table 9-1. Minimum Software Versions for Subtending Operation

Module	Minimum Revision Level
Communications:	
Basic Load	D.00
Basic + NTP	B.00
Basic + SNMP	B.00
Basic + NTP + SNMPv2	B.00
Basic + NTP + SNMPv3	D.00
Clock (ST2 or ST3E)	C.00
Composite Clock Input	A.00
Japan CC Input	A.00
Composite Clock Output	PLD: B.00 S/W: B.00
Japan CC Output	A.00

Required Hardware

The Subtending SSU mode *requires* the following modules in the shelf:

- CC Input module and CC Output module or
- JCC Input module and JCC Output module

All other available modules can be used in the Subtending SSU mode. The shelf must contain the appropriate Clock module(s), Communications module, and Input and Output modules.

Installing Software

The Subtending SSU requires the software listed in [Table 9-2](#):

Table 9-2. Files Required for Upgrading the Firmware

Item Number to be Upgraded	Description	File for Module Firmware Upgrade	File for Module PLD/FPGA Upgrade
23413012-000-0 23413012-001-0 23413012-002-0 23413012-003-0 23413012-004-0 23413012-005-0	Comms Module	01200D00.DN1 01201B00.DN1 01202B00.DN1 01203B00.DN1 01204B00.DN1 01205B00.DN1	SCOMFPGA.DN9
23413015-000-0	Stratum 3E Clock Module	01500C00.DN1	SCLKFPGA.DN9
23413016-000-0	Stratum 2 Clock Module	01500C00.DN1	SCLKFPGA.DN9
23413279-000-0	CC Input Module	27900A00.DN1	SSUCCINP.DN9
23413158-000-0	CC Output Module	15800B00.DN1	SSUCCOUT.DN9
23413307-000-0	JCC Input Module		
23413306-000-0	JCC Output Module		

To install the software you need to use either the SynCraft application or the SSU-2000 Download application

Using the SynCraft Application

To use the SynCraft application to install software, refer to the on-line documentation provided within the program.

Changing From Subtending SSU Mode

To change a Subtending SSU back to the normal mode:

1. Log in to the SSU-2000 and press **Enter**. The system prompt appears.

2. Type `opermode normal` and press **Enter**. The system responds with:

```
2002-08-15-T15:57:56Z ID: SSU2000 Name: SSU_2000
The SSU2000 is in Normal Mode
```

3. Type `bye` and press **Enter** to log off.

No hardware changes are necessary.

SSU-2000 Configuration Chart

A fully-populated SSU-2000 main shelf is shown in [Figure 1-1](#). [Figure 9-4](#) shows the I/O adapter panels used with the SSU-2000 input and output modules. [Figure 9-5](#) shows the SDU-2000 Synchronization Distribution Unit (output expansion shelf) used with the SSU-2000. [Table 9-3](#) contains a listing of all SSU-2000 components, provides the associated Symmetricom part numbers and provides other configuration data required to procure a custom system.

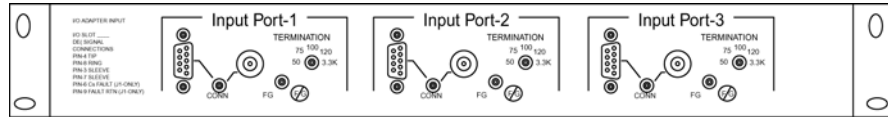

ss200018

I/O Adapter for 3-Port DS1 or E1 Input Module

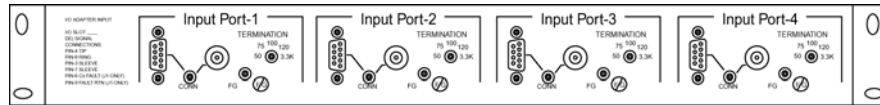

ss200019

I/O Adapter for 1-Port DS1 or E1 Input Module

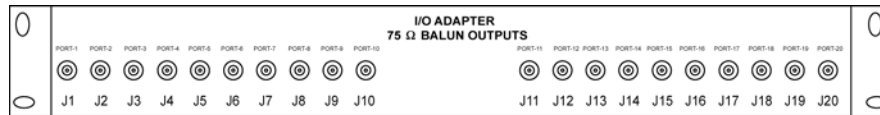

ss200020

75 Ohm Balun I/O Adapter for DS1 or E1 Output Module

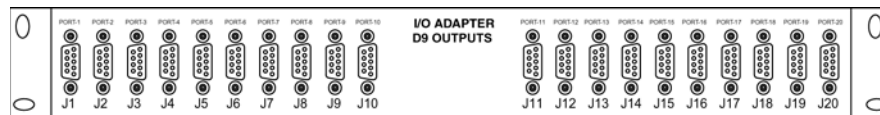

ss200021

DE9 I/O Adapter for DS1 or E1 Output Module

Figure 9-4. SSU-2000 I/O Adapter Panels

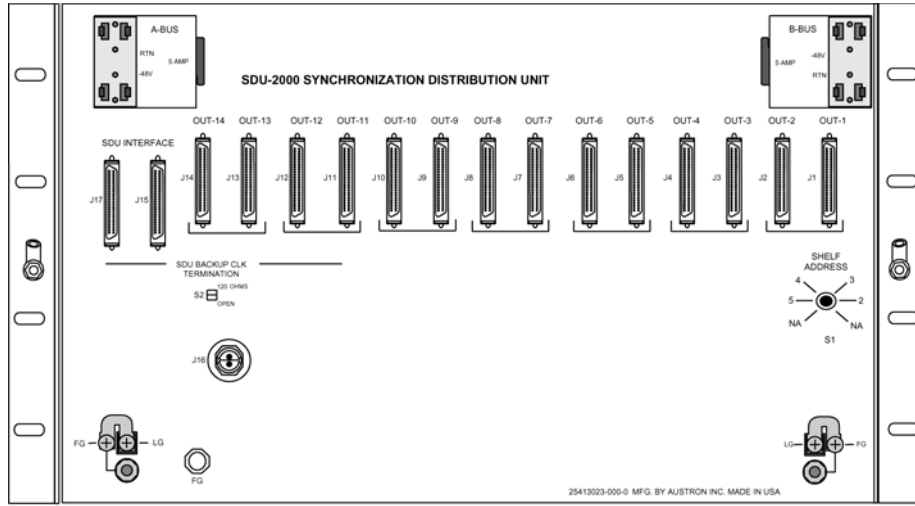

ss200027

Figure 9-5. SDU-2000 Synchronization Distribution Unit

Table 9-3. SSU-2000 System Components

Item	Description	Part Number	Notes
SSU-2000 Main Shelf and Associated Hardware			
1.	SSU-2000 Main Shelf (Chassis) with SDU termination plug and <i>SSU-2000 User's Guide</i> (12713030-002-2)	25413020-000-0	Required for all systems. Requires minimum of one Comms module, one Clock module, one Input module, one Output module, one Input Adapter panel and one Output adapter panel and 8 Filler panels (including one wide panel). If an Expansion shelf (SDU-2000) is not installed, SSU Expansion Terminator, part number 12013049-000-0 must be installed on J8 on the SSU-2000 chassis. Otherwise, the terminator must be installed on the last Expansion shelf in the system.
2.	Bracket, rack ear, 19"	00413020-000-1-2	Two each provided with the main shelf.
3.	Bracket, rack ear, 23", 2 each required	00413020-001-1-2	Two each provided with the main shelf.
Clock Modules			
4.	Stratum 2E Rb Clock Module	23413016-000-0	Minimum of one Clock module per system (item 4, 5, or 6). Redundant configuration with automatic switching in case of clock failure requires two Clock modules. The system operates with 2E/3E clocks combined. 2E clock must be installed in chassis slot A1.

Table 9-3. SSU-2000 System Components (Continued)

Item	Description	Part Number	Notes
5.	Stratum 3E Clock Module	23413015-000-0	Minimum of one Clock module per system (item 4, 5, or 6). Redundant configuration with automatic switching in case of clock failure requires two Clock modules. The system operates with 2E/3E clocks combined. 2E clock must be installed in chassis slot A1.
6.	Type I Clock Module	23413015-001-0	Minimum of one Clock module per system (item 4, 5, or 6). Redundant configuration with automatic switching in case of clock failure requires two Clock modules.
Communications Module			
7.	Communications Module	23413012-000-0	One required per SSU-2000 system.
Input Modules, I/O Adapter Panels and Input Cabling			
8.	3-Port DS1 Input Module	23413013-002-0	1. Accepts up to 3 DS1 or Clock signals. 2. Requires use of 3-Port I/O adapter (one per 3-Port Input module).
9.	1-Port DS1 Input Module	23413013-001-0	1. Accepts one DS1 or Clock signal. 2. Requires use of 4-Port I/O Adapter (one adapter can handle up to four 1-port DS1 or E1 Input modules).
10.	3-Port E1 Input Module	23413014-002-0	1. Any combination of three G.703/9, G.703/13, or Clock inputs. 2. Requires use of 3-Port I/O adapter (one per input module in system).
11.	1-Port E1 Input Module	23413014-001-0	Requires use of 4-Port I/O Adapter (one adapter serves up to four 1-Port Input modules).
12.	GPS Input Module	23413019-000-0	1. Supports NTP provided by the Communications module. 2. Time-of-day provided by the Radio.
13.	CC Input Module	23413279-000-0	1. Accepts one Composite Clock signal. 2. Requires use of 133 Ω Input adapter panel.

Table 9-3. SSU-2000 System Components (Continued)

Item	Description	Part Number	Notes
14.	JCC Input Module	23413307-000-0	<ol style="list-style-type: none"> 1. Accepts one Composite Clock signal with optional 400 Hz component. 2. Requires use of 110 Ω Input adapter panel.
15.	JSW Input Module	23413305-000-0	<ol style="list-style-type: none"> 1. Accepts up to three 1.544 or 6.312 MHz Clock signals. 2. Requires use of 3-Port I/O adapter (one per input module in system).
16.	3-Port SSU I/O Input Adapter Panel	22013066-001-0	<ol style="list-style-type: none"> 1. Use with 3-port DS1 or E1 Input Module. 2. Each port has DE9 and BNC connectors (switch selectable) and selectable termination (50, 75, 100, 120 or 3.3 kΩ). 3. Typically, 100 Ω termination for DS1 signals, 120 Ω for E1 signals, 50 and 75 Ω termination for 2,048 MHz or sine wave signals. 4. Includes 1-m SCSI cable for connection to SSU-2000.
17.	3-Port SSU I/O Input Adapter Panel	22013066-002-0	<ol style="list-style-type: none"> 1. Use with 3-port DS1 or E1 Input module. 2. Each port has DE9 and Siemens 1.6/ 5.6 mm connectors (switch selectable) and selectable termination (50, 75, 100, 120 or 3.3 kΩ). 3. Typically, 100 Ω termination for DS1 signals, 120 Ω for E1 signals, 50 and 75 Ω termination for 2,048 MHz or sine wave signals. 4. Includes 1-m SCSI cable for connection to SSU-2000.
18.	3-Port SSU I/O Input Adapter Panel	22013066-003-0	<ol style="list-style-type: none"> 1. Use with 3-port DS1 or E1 Input module. 2. Each port has DE9 and Siemens 1.0/ 2.3 mm connectors (switch selectable) and selectable termination (50, 75, 100, 120 or 3.3 kΩ). 3. Typically, 100 Ω termination for DS1 signals, 120 Ω for E1 signals, 50 and 75 Ω termination for 2,048 MHz or sine wave signals. 4. Includes 1-m SCSI cable for connection to SSU-2000.

Table 9-3. SSU-2000 System Components (Continued)

Item	Description	Part Number	Notes
19.	4-Port SSU I/O Adapter Panel	22013069-001-0	<ol style="list-style-type: none"> 1. One adapter panel serves up to four 1-port input modules. 2. Each port has DE9 and BNC connectors (switch selectable) and selectable termination (50, 75, 100, 120 or 3.3 kΩ). 3. Typically, 100 Ω termination for DS1 signals, 120 Ω for E1 signals, 50 and 75 Ω termination for 2,048 MHz or sine wave signals. 4. Includes 1-m SCSI cable for connection to SSU-2000.
20.	4-Port SSU I/O Adapter Panel	22013069-002-0	<ol style="list-style-type: none"> 1. One adapter panel serves up to four 1-port Input modules. 2. Each port has DE9 and Siemens 1.6/ 5.6 mm connectors (switch selectable) and selectable termination (50, 75, 100, 120 or 3.3 kΩ). 3. Typically, 100 Ω termination for DS1 signals; 120 Ω for E1 signals; 50 and 75 Ω termination for 2,048 MHz or sine wave signals. 4. Includes SCSI cable for connection to SSU-2000.
21.	4-Port SSU I/O Adapter Panel	22013069-003-0	<ol style="list-style-type: none"> 1. One adapter panel serves up to four 1-port Input modules. 2. Each port has DE9 and Siemens 1.0/ 2.3 mm connectors (switch selectable) and selectable termination (50, 75, 100, 120 or 3.3 kΩ). 3. Typically, 100 Ω termination for DS1 signals; 120 Ω for E1 signals; 50 and 75 Ω termination for 2,048 MHz or sine wave signals. 4. Includes SCSI cable for connection to SSU-2000.
22.	SCSI Cable, 1 m	060-10003-10-2	Connects I/O Adapter to rear panel of the shelf.

Table 9-3. SSU-2000 System Components (Continued)

Item	Description	Part Number	Notes
Output Module, Output I/O Adapter Panels and Output Cables			
23.	E1 Output Module	23413018-000-0	<ol style="list-style-type: none"> 1. Minimum of one Output module of any type required. 2. Each Output module provides 20 single output signals or 20 redundant signals (if desired) in even/odd slots. 3. Each Output module or redundant pair requires one Output I/O adapter panel. 4. Each two redundant Output modules require one Output Summer connector (part number 22013070-000-0).
24.	DS1 Output Module	23413017-000-0	<ol style="list-style-type: none"> 1. Minimum of one Output module of any type required. 2. Each Output module provides 20 single output signals or 20 redundant signals (if desired) in even/odd slots. 3. Each Output module or redundant pair requires one Output I/O adapter panel. 4. Each two redundant Output modules require one Output Summer connector (part number 22013070-000-0).
25.	2048 kHz Output Module	23413159-000-0	<ol style="list-style-type: none"> 1. Minimum of one Output module of any type required. 2. Each Output module provides 20 single phase-locked 2048 kHz clock output signals or 20 redundant phase-locked 2048 kHz clock output signals (if desired) in even/odd slots. 3. Each Output module or redundant pair requires one Output I/O adapter panel. 4. Each two redundant Output modules require one Output Summer connector (part number 22013070-000-0).

Table 9-3. SSU-2000 System Components (Continued)

Item	Description	Part Number	Notes
26.	Composite Clock Output Module	23413158-000-0	<ol style="list-style-type: none"> 1. Minimum of one Output module of any type required. 2. Each Output module provides 20 single byte and polarity phase aligned independently configurable duty cycle (50/50 or 62.5/37.5) and phase delay from 0 to 3.4 msec CC output signals or 20 redundant (if desired) signals of the same type in even/odd slots. 3. Each output module or redundant pair requires one Output I/O adapter panel. 4. Each two redundant Output modules require one Output Summer connector (part number 22013070-000-0).
27.	E1/2048 kHz Output Module	23413292-000-0	<ol style="list-style-type: none"> 1. Minimum of one Output module of any type required. 2. Each Output module provides 20 single phase-locked E1 or 2048 kHz clock output signals or 20 redundant phase-locked E1 or 2048 kHz clock output signals (if desired) in even/odd slots. 3. Each Output module or redundant pair requires one Output I/O adapter panel. 4. Each two redundant Output modules require one Output Summer connector (part number 22013070-000-0).
28.	RS-422 Output Module	23413287-000-0	<ol style="list-style-type: none"> 1. Minimum of one Output module of any type required. 2. Each Output module provides 10 balanced square-wave outputs (TTIP and TRING signal pairs) and 10 single-ended (Ring) square-wave outputs. 3. Outputs can be from 8 to 4096 kHz. 4. Each Output module or redundant pair requires one Output I/O adapter panel. 5. Each two redundant Output modules require one Output Summer connector (part number 22013070-000-0).

Table 9-3. SSU-2000 System Components (Continued)

Item	Description	Part Number	Notes
29.	Japan Composite Clock Output Module	23413306-000-0	<ol style="list-style-type: none"> 1. Minimum of one Output module of any type required. 2. Each Output module generates 20 non-summable pairs with independently configurable phase delay. 3. Each output module or redundant pair requires one Output I/O adapter panel. 4. Each two redundant Output modules require one Output Summer connector (part number 22013070-000-0).
30.	Japan Sine Wave Output Module	23413304-000-0	<ol style="list-style-type: none"> 1. Minimum of one Output module of any type required. 2. Each Output module provides 20 outputs at either 1.544 or 6.312 MHz. 3. Each output module or redundant pair requires one Output I/O adapter panel. 4. Each two redundant Output modules require one Output Summer connector (part number 22013070-000-0).
31.	DS1 Line Re-Timing Module	23413301-000-0 234-13301-001-0	<ol style="list-style-type: none"> 1. Minimum of one Output module of any type required. 2. The dual or quad LRU provides retiming on two or four DS1 lines to a Network Element. 3. A corresponding Cut-Through Assembly is required.
32.	E1 Line Re-Timing Module	23413309-000-0	<ol style="list-style-type: none"> 1. Minimum of one Output module of any type required. 2. The quad LRU provides retiming on four E1 lines to a Network Element. 3. A corresponding Adapter Assembly is required.
33.	SSU I/O Adapter Panel, DS1 100/75 Ω Balun Outputs, BNC connectors	22013068-001-0	<ol style="list-style-type: none"> 1. One adapter required per Output module (or redundant pair of Output modules). 2. Requires separate I/O cable, 50 pin SCSI – see item 40. 3. Optional ears for 21-inch or 23-inch rack.
34.	SSU I/O Adapter Panel, DS1 120/75 Ω Balun Outputs, Siemens 1.6/5.6 mm connectors	22013068-002-0	<ol style="list-style-type: none"> 1. One adapter required per Output module (or redundant pair of Output modules). 2. Requires separate I/O cable, 50 pin SCSI – see item 40. 3. Optional ears for 21-inch or 23-inch rack.

Table 9-3. SSU-2000 System Components (Continued)

Item	Description	Part Number	Notes
35.	SSU I/O Adapter Panel, DS1 120/75 Ω Balun Outputs, Siemens 1.0/2.3 mm connectors	22013068-003-0	<ol style="list-style-type: none"> One adapter required per Output module (or redundant pair of Output modules). Requires separate I/O cable, 50 pin SCSI – see item 40. Optional ears for 21-inch or 23-inch rack.
36.	I/O Adapter Assembly, 9-pin D Outputs (DE9)	22013067-001-0	<ol style="list-style-type: none"> One adapter required per DS1 Output module (or redundant pair Output modules). Requires separate I/O cable, 50 pin-SCSI – see item 40. Optional ears for 21-inch or 23-inch rack.
37.	100-Output (23-in) High-Density Wire-wrap Output Panel	12813171-000-0	<ol style="list-style-type: none"> Includes SCSI cables for connection to SSU-2000.
38.	80-Output (19-in) High-Density Wire-wrap Output Panel	12813282-000-0	<ol style="list-style-type: none"> Includes SCSI cables for connection to SSU-2000.
39.	Adapter, 9-pin to wire-wrap	22013085-000-0	One DE9 I/O connector to wire-wrap adapter for each DE9 I/O connector (optional).
40.	I/O Cable, 50 pin 1 m I/O Cable, 50 pin 1.1 m I/O Cable, 50 pin 1.2 m I/O Cable, 50 pin 1.3 m I/O Cable, 50 pin 1.4 m I/O Cable, 50 pin 1.5 m I/O Cable, 50 pin 1.6 m I/O Cable, 50 pin 1.7 m I/O Cable, 50 pin 1.8 m I/O Cable, 50 pin 1.9 m I/O Cable, 50 pin 2 m	060-10003-10-2 060-10003-11-2 060-10003-12-2 060-10003-13-2 060-10003-14-2 060-10003-15-2 060-10003-16-2 060-10003-17-2 060-10003-18-2 060-10003-19-2 060-10003-19-2	<ol style="list-style-type: none"> One cable (1 to 2 meters in length) required for each Output module or redundant pair of Output modules in the system. Same cables used for Main shelf and Expansion shelf.
41.	805SCSI-TELCO	Cable, 50-pin SCSI to 50-pin TELCO connector	
42.	805SCSI-TLCOR	Cable, 50-pin SCSI, to 50-pin TELCO connector right angle	
43.	Dual Cut-Through Assembly	22013300-000-0	For use with the Dual DS1 Line Re-Timing Module
44.	Quad Cut-Through Assembly	22013300-001-0	For use with the Quad DS1 Line Re-Timing Module

Table 9-3. SSU-2000 System Components (Continued)

Item	Description	Part Number	Notes
45.	Adapter Assembly Output Panel – DE9	22013310-001-0	For use with the E1 Line Re-Timing Module
46.	Adapter Assembly Output Panel – 75 Ω BNC	22013310-002-0	For use with the E1 Line Re-Timing Module
47.	Adapter Assembly Output Panel – 75 Ω Siemens 1.6/5.6mm	22013310-003-0	For use with the E1 Line Re-Timing Module
SDU-2000 Expansion Shelf			
48.	SDU-2000 Synchronization Distribution Unit Expansion Shelf, comes with D-clock cable	25413023-000-0	<ol style="list-style-type: none"> Up to 4 expansion shelves can be attached to one SSU-2000 main shelf. Requires minimum of 1 Buffer module (2 recommended) and up to 14 Output modules (no Input modules). Output modules interchangeable between Expansion shelf and Main shelf. Last Expansion shelf requires SDU termination plug (shipped with Main shelf).
49.	Buffer Module	23413122-000-0	1 or 2 required per SDU-2000 expansion shelf (install in slots A15 and A16).
Blank Filler Panels			
50.	Clock Module Filler Panel (3.2 in. wide)	10913022-000-0	Filler panels are required in all unused clock slots.
51.	Standard Module Filler Panel (1 in. wide)	10913021-000-0	Filler panels are required in all unused SSU-2000 and SDU-2000 I/O slots. The 1-inch panel fits all unused slots in an Expansion shelf and all except A1 and A12 (two end slots) in the Main shelf.
EIA-232 Cable			
52.	Cable, EIA-232 Shielded, DB9P to DB9S, 5 ft. (1.5 m)	551026-0038	Used for communication with the SSU-2000.

Index

Numerics

- 1-1 redundancy [68](#)
- 1-Port DS1 Input module [42](#), [167](#)
- 1-Port E1 Input module [42](#), [158](#)
- 1-port input adapter [192](#)
- 2048 kHz Output module [44](#), [227](#)
 - block diagram [227](#)
 - front panel [231](#)
 - specifications [232](#)
- 3-Port DS1 Input module [42](#), [167](#)
- 3-Port E1 Input module [42](#), [158](#)
- 3-port input adapter [194](#)
- 3-sigma test [160](#), [169](#)

A

- access level
 - overview [94](#)
- accessories
 - cables [262](#)
- adapter panels, I/O [47](#), [48](#), [257](#)
- adapter panels, output [261](#)–[262](#)
- adding a module [106](#)
- adding a user, ICS procedure [96](#)
- administrator
 - adding an administrator-level user [95](#)
 - administrator user level [95](#)
- Alarm Indication Signaling. See AIS
- alarms
 - checking current [113](#)
 - Communications module [154](#)
 - connections [73](#)
 - hex digits [215](#), [221](#), [229](#), [235](#)
 - message format [131](#)
 - modes [33](#)
 - MTIE [169](#)
 - overview [153](#)
 - relays [74](#)
 - terminal blocks [73](#)
- antenna
 - connectors, main shelf [39](#)
 - slot connections [38](#)
- architecture SSU-2000 [27](#)
- autoreturn [29](#)
- autoswitch [29](#)

B

- backing up a configuration [115](#)
- backup clock D [54](#)
- Balun output adapter panel [261](#)
- basic system load [50](#)
- Bipolar Violation. See BPV
- blank filler panels [283](#)
- block diagram
 - 2048 kHz Output module [227](#)
 - CC Input module [180](#)
 - CC Output module [206](#)
 - Communications module [151](#)
 - DS1 Input module [168](#)
 - DS1 Line Re-timing module [242](#), [243](#)
 - DS1 Output module [202](#)
 - E1 Input module [159](#)
 - E1 Line Re-timing Module [254](#)
 - E1 Output module [199](#)
 - E1/2048 kHz Output module [224](#)
 - GPS Input module [176](#), [177](#)
 - Japan CC Input module [190](#)
 - Japan CC Output module [210](#)
 - Japan Sine Wave Input module [183](#)
 - Japan Sine Wave Output module [213](#)
 - RS-422 Output module [233](#)
 - SDU-2000 [56](#)
 - SSU-2000 [27](#)
 - Stratum 2E Clock module [139](#)
 - Stratum 3E Clock module [143](#)
 - Type 1 Clock module [147](#)
- BNO tee connector [77](#)
- Buffer module [259](#)
- bypass clock [30](#)

C

- cable
 - accessory [262](#)
 - backup clock [77](#)
 - EIA-232, part number [283](#)
 - SDU-2000 expansion shelf [77](#)
- calculating MTIE [169](#)
- calculating TDEV [170](#)
- cautions defined [20](#)
- Cesium fault
 - DS1 Input module [172](#)
 - E1 Input module [163](#)
- changing mode [273](#)
- checking current alarms [113](#)

- checklist
 - readiness to test 118
- clock
 - backup 54
 - overview 31
- Clock C 30, 223
- Clock D 54
- Clock module
 - Stratum 2E 41, 138
 - Stratum 3E 41, 142
 - Type 1 42, 146
- clock termination switch S2 77, 79
- commissioning test sheet 124
- communication interfaces, main shelf 70
- communications
 - overview 31
 - port assignments 70, 90
 - port overview 39
 - ports, defined 70
 - protocol 49
- Communications module 42, 150
 - alarm logic 153
 - alarms 154
 - block diagram 151
 - front panel 152
 - software loads 50
- Composite Clock Input module 43, 179
 - block diagram 180
 - default settings 182
 - front panel 181
- Composite Clock Output module 44, 205
 - block diagram 206
 - front panel 207
 - specifications 208
- configuration
 - backing up 115
 - changing 114
 - default, changing 113
 - Ethernet port 92
 - monitor only 26
 - PRS 26
 - restoring 116
 - TSG 25
- connecting 71
- connectors
 - external, main shelf 37
 - local oscillator 72
 - remote reset 72
- critical alarm
 - overview 154
- Cut-Through Assembly
 - installing 247–250
 - overview 240
 - pinout 250

Cyclical Redundancy Check. See CRC

D

- D Clock 54
- DE9 Output Adapter panel 261
- default configurations 113
- default settings
 - CC Input module 182
- defaults, restoring 114
- direct digital synthesis (DDS) 31
- disabling a module, procedure 83
- documentation, related 21
- DS1 Input module
 - block diagram 168
 - Cesium fault 172
 - factory defaults 175
 - front panel 173
- DS1 Line Re-timing module 45, 240
 - block diagram 242
 - front panel 244
 - installing 245–247
 - specifications 252
- DS1 Output module
 - block diagram 202
 - front panel 203
- DTE/DCE switch, location 38
- DTE/DCE switch, serial port 71

E

- E1 Input module
 - block diagram 159
 - Cesium fault 163
 - default values 166
 - front panel 164
- E1 Line Re-timing module 45, 253
 - front panel 255
 - installing 256
 - specifications 258
- E1 Output module 44
 - block diagram 199
 - front panel 200
- E1/2048 kHz Output module 44, 219
 - block diagram 224
 - front panel 225
 - specifications 226
- EIA-232 port 71, 154
 - assignment 70
 - connector pinout 72
 - protocol 70
- electromagnetic interference considerations 61

EMI considerations [61](#)
equipment required
 commissioning tests [119](#)
 installing the shelf [61](#)
error counts, inputs [162](#)
Ethernet port [71](#)
 assignment [70, 90](#)
 configuring [92](#)
 connector [72](#)
 protocol [70, 90](#)
events
 log [153](#)
exchanging a module, procedure [82](#)
expansion shelf. See SDU-2000
expansion terminator [77](#)
external connectors, main shelf [37](#)

F

FG. See frame/logic grounds
filler panels [283](#)
fire protection, fuses [127](#)
format
 alarm message [131](#)
frame ground, isolating [65](#)
frame/logic grounds [40](#)
frequency
 output, setting, RS-422 Output module
 [234](#)
front panel
 2048 kHz Output module [231](#)
 CC Input module [181](#)
 CC Output module [207](#)
 Communications module [152](#)
 DS1 Input module [173](#)
 DS1 Line Re-timing module [244](#)
 DS1 Output module [203](#)
 E1 Input module [164](#)
 E1 Line Re-timing module [255](#)
 E1 Output module [200](#)
 E1/2048 kHz Output module [225](#)
 GPS Input module [178](#)
 Japan CC Input module [191](#)
 Japan CC Output module [211](#)
 Japan Sine Wave Input module [186](#)
 Japan Sine Wave Output module [218](#)
 RS-422 Output module [237](#)
 SSU-2000 [24](#)
 Stratum 2E Clock module [140](#)
 Stratum 3E Clock module [144](#)
 Type 1 Clock module [148](#)
front panel, SDU-2000 [53](#)
fuse replacement warning [127](#)
fuses, main shelf [39](#)

G

Global Services telephone/address [136](#)
GPS antenna
 caution near high voltage lines [75](#)
GPS Input module [176](#)
 block diagram [176](#)
 factory default values [179](#)
 front panel [178](#)
 overview [43](#)
graphical user interface [51](#)
grounding [75, 127](#)
 isolating frame from logic [65](#)
grounding and power, installation [64](#)
GUI. See graphical user interface

H

holdover stability
 Stratum 2E clock module [141](#)
 Stratum 3E Clock module [145](#)
 Type 1 Clock module [149](#)

I

I/O adapter panels [47, 192–195](#)
I/O connectors [37](#)
ICS
 overview [49](#)
idle-level users [95](#)
ignore mode [33](#)
indicators overview [53](#)
input
 reference selection [30](#)
input adapter panels [192–195](#)
input connectors [37](#)
input reference
 overview [28](#)
input wire-wrap adapters [195](#)
inputs
 error counts [162](#)
 SSU-2000 [28](#)
 troubleshooting [134](#)
installation
 completeness checklist [85](#)
 EMI considerations [61](#)
 grounding and power [64](#)
 I/O adapter panels [64](#)
 I/O connections [66](#)
 preliminary procedures [60](#)
 procedure, overview [59](#)
 tools and materials [61](#)

installing modules 81
interference, electromagnetic 61
isolating frame and logic ground 65

J

J4-J5 pinouts 72
Japan CC Input module 43, 189
 block diagram 190
 factory default values 192
 front panel 191
Japan CC Output module 45, 209
 block diagram 210
 factory default values 212
 front panel 211
Japan Sine Wave Input module 43, 182
 block diagram 183
 factory default values 187
 front panel 186
Japan Sine Wave Output module 45, 213
 factory default values 219
 front panel 218
jitter
 Stratum 2E clock module 141
 Stratum 3E Clock module 145
 Type 1 Clock module 149

L

LEDs
 2048 kHz Output module 231
 Buffer module 259
 CC Input module 181
 CC Output module 207
 Communications module 152
 DS1 Input module 173
 DS1 Line Re-timing module 244
 DS1 Output module 203
 E1 Input module 164
 E1 Line Re-timing Module 256
 E1 Output module 200
 E1/2048 kHz Output module 225
 GPS Input module 178
 Japan CC Input module 191
 Japan CC Output module 211
 Japan Sine Wave Input module 186
 Japan Sine Wave Output module 218
 RS-422 Output module 237
 Stratum 2E Clock module 140
 Stratum 3E Clock module 144
 troubleshooting 133
 troubleshooting with 134
 Type 1 Clock module 148
local oscillator connectors 72
logic ground, isolating 65

logic/frame grounds 40
Loss of Signal. See LOS

M

main shelf
 comm ports 39
 connection features 37
 frame/logic grounds 40
 fuses 39
 module assignments 36
 power distribution 38
 terminator 76
major alarm
 overview 154
master controller function 31
materials and tools
 system installation 61
minor alarm
 overview 154
modes
 alarm 33
 fail 34
 report 33
module
 disabling, procedure 83
 exchanging, procedure 82
 removing, procedure 84
modules
 2048 kHz Output module 44, 227
 2E Clock module 41
 adding or enabling 106
 Buffer 259
 Communications module 42, 146, 150
 Composite Clock Input 43, 179
 Composite Clock Output module 44, 205
 disabling 107
 DS1 Input module 42, 167
 DS1 input module, factory defaults 175
 DS1 Line Re-timing module 240
 DS1 Output module 44, 202
 E1 Input module 42, 158
 E1 Line Re-Timing module 253
 E1 Output module 44, 198
 E1 Output module, specifications 201
 GPS Input module 43, 176
 handling precautions 81
 installing, procedure 81
 Japan CC Input 189
 Japan CC Output 209
 Japan Sine Wave Input module 43, 182
 overview 40
 power supplies 39
 redundant 68
 removing 107

- RS-422 Output module [44](#)
- Stratum 2E Clock module [41](#), [138](#)
- Stratum 3E Clock module [41](#), [142](#)
- Type 1 Clock module [42](#), [146](#)
- monitor-only configuration [26](#)
- MTIE
 - alarms [160](#), [169](#)
 - calculation [160](#), [169](#)
 - description [160](#)

N

- non-revertive mode [29](#)
- normal mode
 - changing to [273](#)
- notes defined [20](#)
- NTP [49](#)

O

- operation overview, SSU-2000 [51](#)
- OPERMODE command [271](#)
- ordering
 - blank filler panels [283](#)
 - by part number [275](#)
 - cables [282](#)
- Out of Frame. See OOF
- output connectors [37](#)
- output redundancy [68](#)
- outputs
 - adapter panels [261–262](#)
 - failed, identifying [215](#), [222](#), [230](#), [236](#)
 - Line Re-timing adapter panels [257](#)
 - overview [31](#)
 - RS-422 Output module, frequency [234](#)
 - scquelching, 2048 kHz Output module [228](#)
 - scquelching, E1/2048 kHz Output module [220](#)
 - scquelching, JSW Output module, TL1 [214](#)
 - scquelching, RS-422 Output module [234](#)
 - troubleshooting [134](#)
- overview
 - indicators and control [53](#)
 - installation procedure [59](#)
 - operation [51](#)

P

- packaging for shipment [135](#)
- panels, blank filler [283](#)
- part numbers
 - backup clock cable [77](#)
 - blank filler panels [283](#)
 - BNO tee connector [77](#)

- EIA-232 cable [283](#)
- expansion cable for SDU-2000 [77](#)
- expansion terminator [77](#)
- I/O Adapter panels [281](#)
- I/O cables [282](#)
- input wire-wrap adapters [195](#)
- modules [128](#)
- SSU-2000 system [275](#)
- password requirements [93](#), [96](#)
- performance specifications [24](#)
- phase buildout
 - description [159](#)
- pinouts
 - 3-port input adapter [194](#)
 - Cut Through Assembly [250](#)
 - EIA-232 [72](#)
- PQL
 - and scquelching outputs [220](#), [228](#), [234](#)
- primary reference source configuration [26](#)
- priority mode
 - overview [30](#)
- product overview, SSU-2000 [23](#)
- protocol, communications [49](#)
- PRS configuration [26](#)

Q

- quality level
 - SSM [51](#)
- quartz oscillator [142](#)

R

- rack mounting instructions [62](#)
- rear panel
 - SDU-2000 [54](#)
 - SSU-2000 [37](#)
- recommendations defined [20](#)
- redundancy, Output modules [46](#), [68](#)
- reference switching
 - overview [30](#)
- related documentation [21](#)
- relays
 - specifications [74](#)
- remote reset connector [72](#)
- removing a module, procedure [84](#)
- report mode [33](#)
- restoring a configuration [116](#)
- restoring factory defaults [114](#)
- return material authorization [136](#)
- returning products to factory, procedure [135](#)
- revertive mode [29](#)
- RMA. See return material authorization

RS-232. See EIA-232
 RS-422 Output module [44](#), [233](#)
 block diagram [233](#)
 front panel [237](#)
 specifications [238](#)
 rubidium oscillator [41](#)

S

S1 shelf address switch [77](#), [79](#)
 S2 clock termination switch [77](#), [79](#)
 SDU-2000
 backup clock cable [77](#)
 block diagram [56](#)
 BNO tee connector [77](#)
 communications interface, procedure [75](#)
 connectors [75](#)
 expansion cable [77](#)
 expansion terminator [77](#)
 front panel [53](#)
 installing a single shelf [77](#)
 installing multiple shelves [78](#)
 rear panel [54](#)
 setting address [57](#)
 shelf address switch [77](#), [79](#)
 specifications [58](#)
 switch S1-S2 [77](#), [79](#)
 synchronization distribution unit [53](#)
 security
 overview [93](#)
 security log [94](#)
 selecting the system reference [29](#)
 serial port [70](#), [154](#)
 assignment [70](#), [90](#)
 connecting [71](#)
 pinouts [72](#)
 protocol [70](#), [90](#)
 shipping address, repair [136](#)
 shipping products to factory, procedure [135](#)
 Simple Network Management Protocol. See SNMP
 SNMP
 overview [49](#)
 software
 versions [50](#)
 specifications
 2048 kHz Output module [232](#)
 CC Output module [208](#)
 DS1 Line Re-timing module [252](#)
 E1 Line Re-timing module [258](#)
 E1 Output module [201](#)
 E1/2048 kHz Output module [226](#)
 RS-422 Output module [238](#)
 Stratum 2E Clock module [141](#)

 Stratum 3E Clock module [145](#)
 Type 1 Clock module [149](#)
 squelch
 2048 kHz Output module [228](#)
 E1/2048 kHz Output module [220](#)
 Japan Sine Wave Output module [214](#)
 RS-422 Output module [234](#)
 SSM
 overview [51](#)
 SSU-2000
 architecture [27](#)
 block diagram [27](#)
 clock section [31](#)
 communications section [31](#)
 front panel [24](#)
 fuses [39](#)
 input section [28](#)
 modules [40](#)
 Output section [31](#)
 power supplies [39](#)
 product overview [23](#)
 rear panel [37](#), [67](#)
 system components [34](#)
 terminator, expansion [76](#)
 Stratum 2E Clock module [41](#), [138](#)
 block diagram [139](#)
 front panel [140](#)
 specifications [141](#)
 Stratum 3E Clock module [41](#), [142](#)
 block diagram [143](#)
 front panel [144](#)
 specifications [145](#)
 structure of this guide [19](#)
 subtending mode
 setting, procedure [272](#)
 summer adapter
 installing [68](#)
 supervisor-level users [95](#)
 switch S1-S2 [77](#), [79](#)
 Symmetricom
 Global Services address [136](#)
 synchronization status messages. See SSM
 SynCraft [51](#)
 system components [34](#)
 system configurations [25](#)
 system load
 basic [50](#)
 system modules [34](#)
 system reference, selecting [29](#)

T

TDEV
 calculation [161](#), [170](#)

technician-level users [95](#)
Telcordia Technologies (formerly Bellcore)
 GR-1244 [29](#)
 GR-378 [29](#)
telephone contact numbers [136](#)
Telnet ports. See Ethernet port
terminator
 clock, S2 on rear panel [77](#), [79](#)
 expansion shelf [76](#)
 SSU-2000 and SDU-2000 [76](#)
test data sheet [124](#)
TL1
 overview [49](#)
tools and materials
 system installation [61](#)
troubleshooting [129](#)
TSG configuration [25](#)
Type 1 Clock module [42](#), [146](#)
 block diagram [147](#)
 front panel [148](#)
 specifications [149](#)

U

unpacking and inspection [60](#)
user
 access levels [94](#)
 adding an administrator-level [95](#)
 adding, ICS [96](#)
user-level users [95](#)

V

ventilation precautions, considerations [62](#)

W

wander
 Stratum 2E Clock module [141](#)
 Stratum 3E Clock module [145](#)
 Type 1 Clock module [149](#)
warnings defined [20](#)
web address [22](#)
wire-wrap adapters [195](#)
wire-wrap adapters, input [195](#)
wire-wrap panel, high-density [262](#)

